



DOUGLAS COUNTY

COMMUNITY DEVELOPMENT DEPARTMENT

1594 Esmeralda Avenue, Post Office Box 218,

Minden, Nevada 89423

TEL (775) 782-6224 * FAX (775) 782-9007

permitdesk@douglasnv.us / www.douglascountynv.gov

Solar Photovoltaic Submittal Requirements

Cover Sheet

- Name, title, registration number, address, and telephone number of applicable design professional(s)
- List contractor name, address, contact information, and Nevada contractor's license number
- Site address and owner information
- Wet/Digital signature on all documents by design professional(s) (i.e.) person drawing plans), date of design
- List all adopted codes and amendments, current adopted design criteria, construction type, occupancy class, sheet index, and concise scope of work, solar array size
- General notes if applicable

Plot/Site Plan

- All property lines, location of the existing building, and all additional structures on the lot
- Show all equipment and shut off locations to include existing electrical main panel
- Show topographical panel layout for roof mount with fire access
- Show solar array with clearances and screening for ground mount systems
- Show north arrow, all trenching setbacks from property lines

Roof / Foundation Details

- List module and bracketing information (Roof Mount System)
- List roof framing information i.e. roofing material, truss size, and truss spacing
- Show roof bracketing detail
- Show foundation detail complete with hole dimensions (Ground Mount System)

Electrical

- One-line or three-line electrical diagram with equipment, conduit layout connecting equipment with size
- Main service panel bus rating, max current rating, solar breaker size, main breaker size
- Wire size calculations and conduit fill factor

Labels

- Provide label diagram with a list of locations and equipment served

Manufactures Information

- Equipment specifications for Inverters, Power Optimizer, Panel, Brackets, and railing

Other potential documents

- HOA approval, TRPA approval

For information purposes only:

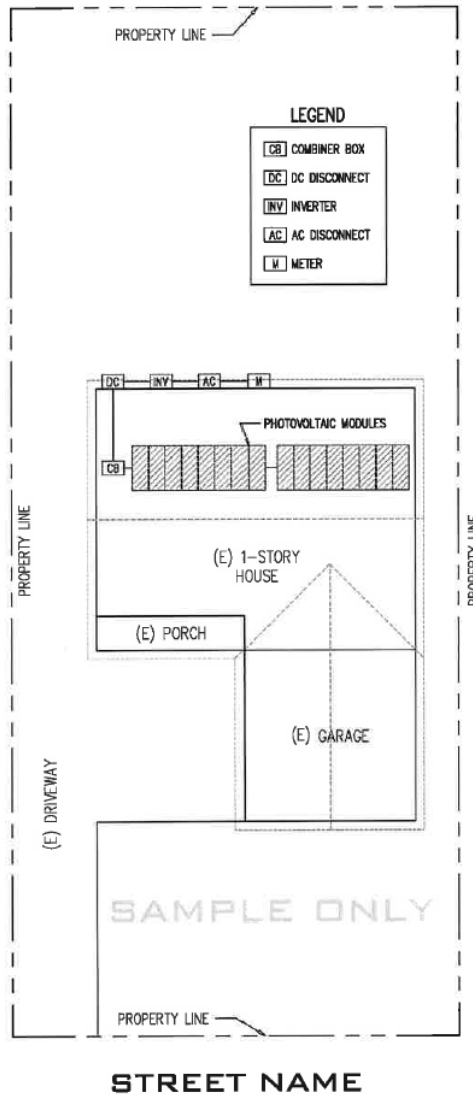

Sample Line Diagram

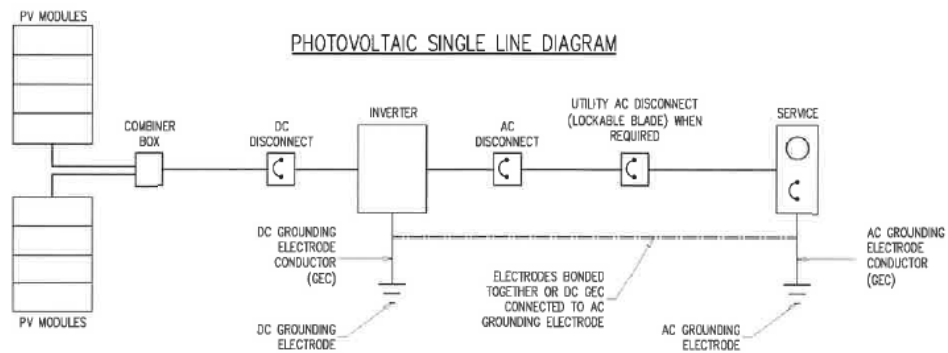

- ALL WIRING IN A SOLAR PHOTOVOLTAIC SYSTEM SHALL BE IDENTIFIED
- FOR INFORMATIONAL PURPOSES ONLY.

Please note that a response by Douglas County Community Development staff in person, to a phone call or an e-mail does not constitute an approval of any application. We strongly encourage you to consult with a legal or real estate professional if you have concerns about whether your proposed actions are appropriate under the laws of Nevada or the Douglas County Code.