

Design Criteria and Improvement Standards



NEVADA

Resolution No. 2017R-039 Adopted June 15, 2017
Resolution No. 2007 R-014 Adopted June 7, 2007
Resolution No. 2001 R-080 Adopted September 6, 2001
Resolution No. 99R-024 Adopted March 4, 1999
Resolution No. 98R-084A Adopted September 17, 1998

Part II
Engineering Design Criteria and Improvement Standards
Table of Contents

Division 1. Introduction

1.1	General	1-1
1.2	Related Documents.....	1-1
1.3	Variance Procedures.....	1-2
1.4	Interpretation and Conflict	1-2
1.5	Updates.....	1-3
1.6	Adoption.....	1-3
1.7	Compliance with Updates to this Manual	1-3

Division 2. Improvement Plans

2.1	General	2-1
2.2	Requirements.....	2-1
2.2.1	Title Sheet	2-1
2.2.2	Utility Index	2-2
2.2.3	Right-of-Way and Easements.....	2-3
2.2.4	Topography	2-3
2.2.5	Stationing and Orientation.....	2-3
2.2.6	Basis of Bearing and Bench Marks	2-4
2.2.7	Typical Section.....	2-4
2.2.8	Cross Sections	2-4
2.2.9	Grading.....	2-4
2.2.9.1	Grading Plan Requirements.....	2-4
2.2.10	Grading Design Criteria	2-6
2.2.11	Erosion Control Design Criteria.....	2-7
2.2.11.1	General	2-7
2.2.11.2	Temporary Erosion Control Standards.....	2-7
2.2.11.3	Permanent Erosion Control Standards.....	2-8
2.2.12	Site Drainage	2-8
2.2.13	Plan and Profile Sheets.....	2-8
2.2.13.1	Streets and Access Roads	2-8
2.2.13.2	Water Systems	2-9
2.2.13.2.1	Water System Improvement Plans	2-9
2.2.13.2.2	Improvement Plan Requirements	2-9

2.2.13.3	Sanitary Sewers	2-10
2.2.13.3.1	Sanitary Sewer Systems and Facilities Improvement Plans.....	2-10
2.2.13.3.2	Improvement Plan Requirements	2-10
2.2.13.4	Storm Drains.....	2-11
2.2.13.4.1	Improvement Plan Requirements	2-11
2.2.13.5	Electric, Telephone and Gas Utilities.....	2-12
2.2.13.6	Existing Utilities.....	2-12
2.2.13.7	Landscaping.....	2-12
2.2.13.8	Details.....	2-12
2.2.13.9	Record Drawings.....	2-13
2.2.14	Traffic Control Plans.....	2-13
2.3	Permit Requirements	2-13
2.4	Changes in Plans	2-13
2.5	References	2-14
	General Notes.....	2-15

Division 3. Streets and Traffic
--

3.1	General	3-1
3.2	Standards	3-1
3.3	Street Widths and Alignment	3-1
3.4	Access	3-2
3.5	Right-of-Way and Easements.....	3-2
3.6	Streets Along Property Boundaries	3-3
3.7	Half Streets.....	3-3
3.8	Pavement Sections.....	3-3
3.9	Design Requirements	3-3
3.9.1	Street Grades	3-4
3.9.2	Street Intersection.....	3-4
3.9.3	Street Crown.....	3-5
3.9.4	Vertical Curves.....	3-5
3.9.5	Horizontal Curves	3-5
3.9.6	Broken-Back Curves	3-5
3.9.7	Median Openings	3-5
3.9.8	Intersection Angles.....	3-6
3.9.9	Private Streets.....	3-6
3.9.10	Asphalt Concrete Structural Sections.....	3-6
3.9.11	Knuckles/Hammerheads.....	3-14
3.9.12	Cul-De-Sacs and Dead End Streets	3-14

3.9.13	Emergency Access Roads	3-14
3.9.14	Improved Maintenance Access	3-15
3.9.15	Retaining Walls	3-15
3.9.16	Signs	3-15
3.9.17	Pavement Markings	3-15
3.9.18	Roadway Shoulders	3-16
3.9.19	Roadside Hazards	3-16
3.10	Sidewalks, Curb and Gutter, Driveway Approaches, Curb-Cuts, Alleys and Bikeways	3-18
3.10.1	General	3-18
3.10.2	Driveway Access	3-18
3.10.2.1	Residential Driveways	3-18
3.10.2.2	Non-Residential Driveways	3-18
3.10.3	Pedestrian Ramps	3-19
3.10.4	Curb and Gutters	3-19
3.10.5	Chamfered Edge at Street Intersections	3-19
3.10.6	Curb Returns	3-19
3.10.7	Bicycle Lanes and Bicycle Routes	3-19
3.10.8	Bicycle and Pedestrian Paths	3-19
3.10.9	Obstructions	3-20
3.10.10	Cut and Fill Slopes	3-20
3.10.11	Alleys	3-20
3.11	Traffic and Impact Study Requirements	3-20
3.11.1	General	3-20
3.11.2	Scope of Work and Method	3-21
3.11.3	Preliminary Site Plan Review	3-21
3.11.4	Traffic Engineering Study Requirements	3-21
3.11.4.1	Previous Traffic Studies	3-21
3.11.4.2	Master Plan, Zoning and/or Tentative Map Applications	3-22
3.11.4.3	Scope of Traffic Engineering Study	3-22
3.15	References	3-29

Division 4. Water Systems

4.1	Design Criteria	4-1
4.1.1	Water Supply Pressure	4-1
4.1.2	Water Demand Rates	4-1
4.1.3	Required Fire Flow	4-1
4.1.4	Maximum Velocities	4-1
4.2	Preliminary Engineering Report	4-2
4.3	Water Rights	4-2
4.4	Distribution Mains Size and Materials	4-3

4.5.1	Distribution Main Bedding.....	4-3
4.5.2	Main Location	4-3
4.5.3	Utility Clearances.....	4-3
4.5.4	Stream and Ditch Crossings	4-5
4.5.5	Valves.....	4-4
4.5.6	Fire Hydrants.....	4-4
4.5.7	Services	4-5
4.5.8	Locating Tape.....	4-5
4.5.9	Permits.....	4-5
4.5.10	Hot Taps	4-5
4.5.11	Blowoffs (Flush Valves)	4-6
4.5.12	Air and Vacuum Valves and Air Release Valves.....	4-6
4.5.13	Pressure Reducing Valves	4-6
4.5.14	Cross Connection	4-6
4.5.15	Backflow Prevention Devices	4-7
	4.5.14.1 Vacuum Breakers	4-7
	4.5.14.2 Spill Resistant Pressure Vacuum Breaker (SVB).....	4-7
4.5.15	Assembly Requirements.....	4-7
4.5.16	Testing Requirements.....	4-7
4.5.17	Installation Requirements.....	4-8
4.5.18	Disinfection and Testing	4-8
4.5.19	Length of Open Trench in Street Areas.....	4-8
4.5.20	Dewatering	4-8
4.5.21	Pipeline Installation.....	4-9
4.5.22	Location and Alignment.....	4-9
4.6	Water Supply Wells.....	4-9
4.6.1	General	4-9
4.6.2	Design Criteria	4-9
	4.6.2.1 Location.....	4-9
	4.6.2.2 Well Capacity Criterion.....	4-10
	4.6.2.3 Water Quality	4-10
	4.6.2.4 Standards	4-10
	4.6.2.5 Casing.....	4-10
	4.6.2.6 Well Screen	4-10
	4.6.2.7 Gravel Pack	4-10
	4.6.2.8 Drilling Method and Borehole Geophysical Logs.....	4-10
	4.6.2.9 Plumbness and Alignment.....	4-10
	4.6.2.10 Test Pumping.....	4-10
	4.6.2.11 Disinfection	4-12
	4.6.2.12 Grouting and Sealing.....	4-12
4.6.3	Hydrogeologic Evaluation and Improvement Drawings.....	4-12
4.6.4	Construction	4-12
4.6.5	Development	4-13
4.6.6	Yield and Efficiency Testing.....	4-13
4.6.7	Water Quality	4-14
4.6.8	Downhole Color Television Survey	4-14
4.6.9	Well Construction Record Report	4-14
4.7	Pumping Facilities.....	4-15

4.7.1	General	4-15
4.7.2	Well Pumps	4-15
4.7.3	Booster Pumps.....	4-16
4.7.4	Mechanical Requirements	4-16
4.7.5	Chlorination.....	4-17
4.7.6	Buildings	4-17
4.7.7	Stand-by Generator.....	4-17
4.8	Water Storage Tanks	4-19
4.8.1	General	4-19
4.8.2	Design Criteria	4-19
4.8.3	Materials.....	4-20
4.8.4	Appurtenances.....	4-20
4.8.5	Painting.....	4-21
4.8.6	Site Work.....	4-21
4.8.7	Inspection and Testing.....	4-21
4.8.8	Disinfection and Volatile Organic Compound Sampling and Testing	4-21
4.9	Treatment Facilities.....	4-22
4.10	Controls and Alarms.....	4-22
4.11	Springs	4-22
4.12	Record Drawings.....	4-23
4.13	Operations and Maintenance Manual.....	4-23
4.14	Facility Start-Up.....	4-25
4.15	References	4-26

Division 5. Sewer Systems

5.1	Sanitary Sewer Systems and Facilities	5-1
5.1.1	Sewer Study and Main Analysis	5-1
5.1.2	Design Requirements	5-2
5.1.2.1	General Criteria	5-2
5.1.2.2	Depth of Pipeline Installation.....	5-2
5.1.2.3	Pipe Size and Material.....	5-3
5.1.2.4	Utility Clearances	5-3
5.1.2.5	Pipe Slope.....	5-3
5.1.3	Steep Slope Protection.....	5-4
5.1.4	Pipeline Bedding and Backfill.....	5-5
5.1.5	Length of Open Trench in Street Areas.....	5-5
5.1.6	Dewatering	5-6
5.1.7	Pipeline Installation.....	5-6
5.1.8	Location and Alignment.....	5-6
5.1.9	Manholes	5-6
5.1.10	Laterals	5-7
5.1.11	Stream and Ditch Crossings	5-8

5.1.12	Boring or Jacking	5-8
5.1.13	Testing.....	5-8
	5.1.13.1 Sewer Main Television Inspection	5-9
	5.1.13.2 Deflection Test	5-9
5.2	Wastewater Pump Stations and Force Mains	5-9
5.2.1	General	5-9
5.2.2	Design Report.....	5-10
5.2.3	Improvement Plans.....	5-10
5.2.4	Flows	5-11
5.2.5	Pump Station Requirements	5-11
	5.2.5.1 Wet Well	5-11
	5.2.5.2 Interior Linings and Waterproofing.....	5-12
	5.2.5.3 Wet Well Access	5-12
5.2.6	Pump Station Piping.....	5-12
5.2.7	Pumps	5-12
5.2.8	Overflow Prevention	5-13
5.2.9	Stand-by Generator.....	5-13
5.2.10	Electrical.....	5-14
5.2.11	Controls and Alarms.....	5-15
5.2.12	Force Mains.....	5-15
5.2.13	Flow Metering	5-16
5.2.14	Flood Protection	5-16
5.2.15	Applicable Design Codes	5-16
5.2.16	Start-up and Operation	5-16
5.2.17	Operations and Maintenance Manual.....	5-17
5.3	On-Site Sewage Disposal Systems.....	5-18
5.4	Wastewater Treatment Facilities.....	5-18
5.5	References	5-19

Division 6. Storm Drainage

6.1	Statutory Authority.....	6-1
6.1.1	Stormwater Drainage System.....	6-1
6.1.2	Water Rights.....	6-1
6.1.3	Reasonable Use of Drainage	6-1
	6.1.3.1 Increase in Rate of Flow.....	6-1
	6.1.3.2 Change in Manner of Flow.....	6-1
	6.1.3.3 Diversion of Drainage	6-2
	6.1.3.4 Water Quality	6-2
	6.1.3.5 Drainage Improvements	6-2
	6.1.3.6 Floodplain Management.....	6-2
	6.1.3.7 Low Impact Design	6-3
6.1.4	Storm Runoff Detention	6-3
6.1.5	Storm Runoff Retention and Infiltration	6-3
6.1.6	Drainage Facilities Maintenance	6-4
6.1.8	Drainage Easements	6-4

6.2	Submittal and Review Process	6-4
6.3	Conceptual Drainage Study.....	6-5
6.3.1	Conceptual Drainage Study Outline.....	6-6
6.4	Technical Drainage Study	6-7
6.4.1	Technical Drainage Study Contents	6-8
6.4.2	Technical Drainage Study Plan.....	6-12
6.5	Technical Criteria.....	6-13
6.5.1	Hydrology.....	6-13
6.5.2	Storm Runoff Determination.....	6-14
6.5.3	Streets.....	6-14
6.5.4	Culvert Design.....	6-16
6.5.4.1	Culverts	6-16
6.5.4.2	Design Storm Frequency	6-16
6.5.4.3	Minimum Size	6-16
6.5.4.4	Culvert Materials.....	6-16
6.5.4.5	Driveway Crossing Culverts	6-16
6.5.4.6	Headwater Criteria	6-16
6.5.4.7	Tailwater Criteria	6-17
6.5.4.8	Alignment.....	6-17
6.5.4.9	Multiple Barrel Culverts.....	6-17
6.5.4.10	Inlet and Outlet Configuration.....	6-17
6.5.4.11	Structural Design.....	6-17
6.5.5	Storm Drains	6-17
6.5.5.1	Storm Drain Hydraulic Analysis	6-17
6.5.5.2	Allowable Storm Drain Capacity	6-17
6.5.5.3	Allowable Storm Drain Velocity.....	6-18
6.5.5.4	Minimum Storm Drain Slope.....	6-18
6.5.5.5	Manning’s Roughness Coefficient	6-18
6.5.5.6	Minimum Pipe Size	6-18
6.5.5.7	Minimum Cover	6-18
6.5.5.8	Manhole and Junction Spacing.....	6-18
6.5.5.9	Horizontal Alignment.....	6-19
6.5.5.10	Utility Clearances	6-19
6.5.5.11	Storm Inlet and Catch Basin Types, Location, and Capacity Factors	6-20
6.5.5.12	Sand/Oil Interceptor	6-20
6.5.5.13	Storm Drain Pipe Material and Shape.....	6-20
6.5.5.14	Length of Open Trench in Street Areas.....	6-21
6.5.5.15	Dewatering	6-21
6.5.5.16	Pipe Installation.....	6-21
6.5.5.17	Location and Alignment.....	6-21
6.5.5.18	Storm Drain Outlet Protection.....	6-22
6.5.6	Drainage Channels	6-22
6.5.7	Detention Facilities.....	6-22
6.5.7.1	Detention/Retention Design Guidelines and Standards.....	6-23
6.5.7.1.1	Detention Facilities.....	6-23

	6.5.7.1.2 Flow Restrictor Outlets	6-25
	6.5.7.1.3 Minimum Outlet Conduit Size	6-25
	6.5.7.1.4 Emergency Spillways	6-25
	6.5.7.1.5 Debris and Sedimentation	6-25
	6.5.7.1.6 Trash Racks	6-25
	6.5.7.1.7 Embankment Protection	6-25
	6.5.7.1.8 Maintenance Requirements	6-25
	6.5.7.1.9 Detention Basin Siting Guidelines	6-26
6.6	References	6-27

Division 7. Irrigation Plans

7.1	Statutory Authority	7-1
	7.1.2 Irrigation Ditches	7-1
7.2	Irrigation Facilities Standards	7-1
	7.2.1 Length of Open Trench in Street Areas	7-2
	7.2.2 Dewatering	7-2
	7.2.3 Pipeline Installation	7-3
	7.2.4 Location and Alignment	7-3

Division 8. Geotechnical Engineering Reports

8.1	General	8-1
8.2	Geotechnical Engineering Report	8-1
	8.2.1 General Requirements	8-1
	8.2.2 Slope Stability Considerations	8-2
	8.2.3 Geotechnical Parameters	8-2
	8.2.4 Rising Water Considerations	8-3
8.3	Post Construction Report	8-3
8.4	References	8-4

Division 9. Easements

9.1	Requirements	9-1
9.2	Easement Size	9-1
9.3	Easement Location	9-2

Division 10. Street Lighting

10.1	General	10-1
10.2	Design Criteria	10-1
10.3	Luminaire Location	10-1
10.4	Improvement Plans.....	10-2

Division 11. Inspection and Testing

11.1	General	11-1
11.2	Responsibilities	11-1
11.2.1	Owner.....	11-1
11.2.2	Contractor.....	11-2
11.2.3	County Engineer.....	11-3
11.2.4	Engineer of Record.....	11-4
11.2.5	Quality Control Testing Firm.....	11-4
11.3	Inspection Requirements	11-5
11.3.1	General	11-5
11.3.2	Preconstruction.....	11-5
11.3.3	Construction	11-5
11.4	Delegation of Inspection Authority	11-7
11.4.1	General	11-7
11.4.2	Delegation of Inspection Authority Procedure.....	11-7
11.5	Testing Services	11-8
11.5.1	General	11-8
11.5.2	Testing Firm	11-8
11.5.2.1	Laboratory	11-8
11.5.2.2	Individuals.....	11-8
11.6	Capital Projects Completed by a Public Agency.....	11-9
11.6.1.1	General	11-9
11.6.1.2	Inspections.....	11-9
11.7	Public Utility Companies that Operate Under a Franchise Agreement or Private Utility Companies	11-9

List of Tables

<u>Table No.</u>		<u>Page No.</u>
Division 2. Improvement Plans		
2.1	General Notes.....	2-1
Division 3. Streets and Traffic		
3.0	Road Spacing for Intersections With Arterial or Collector Roadways	3-2
3.1	Minimum Right-of-Way Widths.....	3-2
3.2	Example Table for Calculating Design ESAL by Vehicle Class ...	3-9
3.3	Vehicle Distribution and Average ESAL's (Flexible Pavements) .	3-11
3.4	Traffic Growth Factors.....	3-12
3.5	Type of Asphalt Concrete Pavement Required	3-13
3.6	Example Format for Regulatory Traffic Control Device Listing...	3-17
3.7	Sample Table of Contents for Site Traffic Access and Impact Study Report.....	3-26
Division 4. Water Systems		
4.1	Source Water and Treatment Production Capacity per Residential Equivalent.....	4-1
4.2	Water System Improvement Checklist.....	4-27
Division 5. Sewer Systems		
5.1	Minimum Slopes for Sewer Pipe.....	5-4
5.2	Bedding Material Wet Trenches.....	5-5
5.3	Maximum Distance Between Manholes.....	5-7
Division 6. Storm Drainage		
6.1	Drainage Study Submittal Requirements	6-5
6.2	Longitudinal Street Flow – 25-year Return Storm.....	6-15
6.3	Street Capacity Limitations for 100-Year Storm.....	6-15
6.4	Allowable Storm Inlet Types and Capacity Factors.....	6-19
Division 9. Easements		
9.1	Required Easement Size.....	9-1
Division 10. Street Lighting		
10.1	Minimum Average Foot Candle Requirements.....	10-1
10.2	Minimum Average Foot Candle Requirements for Intersections...	10-2
10.3	Minimum Average Uniformity Ratio.....	10-2
10.4	Average Maintained Lumens	10-2
10.5	Maximum Luminaire Spacing.....	10-3

Appendices

Appendix A - Street Improvement Details	Drawing No.
Arterial/Collector Typical Road Section	DC-A01
Local Road Section	DC-A02
Unpaved Road Section	DC-A03-A
Pedestrian Path/Bikeway Class I.....	DC-A04
Type 1 PCC Curb & Gutter.....	DC-A05-A
PCC Median Curb	DC-A05-B
Typical Sidewalk.....	DC-A06
Mid-Block Curb Ramp With Detached Sidewalk.....	DC-A07-A
Mid-Block Curb Ramp With Attached Sidewalk.....	DC-A07-B
Linear Curb Ramp Single Adjacent	DC-A07-C
ADA Pedestrian Ramps Old Town Corner Ramps	DC-A07-D
Curb Ramp General Notes.....	DC-A07-E
Urban Residential PCC Driveway Apron.....	DC-A08-A
Rural Residential Driveway Apron	DC-A08-B
PCC Driveway Apron (Non-Residential) & Local Road Valley Gutter	DC-A08-C
PCC Valley Gutter (Alleys).....	DC-A09
Typical Alley Sections (PCC and AC).....	DC-A10-A
PCC Alley Jointing Details	DC-A10-B
PCC Jointing.....	DC-A11
Monuments.....	DC-A12
Temporary Cover	DC-A13
Street Cut Repair	DC-A14
Typical Utility Main Locations	DC-A15
Typical Utility Laterals Location	DC-A16
Cluster Box Turnouts	DC-A17
Street Name Sign.....	DC-A18-A
Standard Street Sign	DC-A18-B
Guide Post Detail.....	DC-A19
Bollard.....	DC-A20
Type 7 & 14 Pole Lighting and Underground Electrical Service.....	DC-A21-A
Pole Grounding & Splice.....	DC-A21-B
Safety Base	DC-A21-C
Underground Electrical Service	DC-A21-D
Traffic Rated Electrical Pull Box	DC-A21-E
I.I.S.N.S Safety Cable	DC-A22
Local Industrial Typical Road Section	DC-A23
Appendix B - Water System Details	
Trench Excavation and Backfill	DC-B01
Water Stop.....	DC-B02
Water Service	DC-B03
3/4" – Single & Double Service Pit, 1" Meter Single Service Pit.....	DC-B04
1 ½" to 2" Meter Set.....	DC-B05
3" to 8" Meter Set.....	DC-B06
1" Dual Meter Set.....	DC-B06

Service Saddle (3/4" to 2").....	DC-B07
Tapping Sleeve.....	DC-B09
Valve.....	DC-B10
Valve Box.....	DC-B11
Thrust Blocks.....	DC-B12
Thrust Block for Upward Thrust.....	DC-B13
Fire Hydrant Assembly.....	DC-B14
Combination Air Valve Assembly.....	DC-B15
Check-Valve Detail.....	DC-B16
Backflow Prevention Assembly (RP).....	DC-B17
Reduced Pressure Principle (RP) Assembly External Backflow Preventer ..	DC-B17
Air Gap Separation.....	DC-B18
Pressure Reducing Valve Station.....	DC-B19
Eclipse No. 88 Sampling Station.....	DC-B20
Douglas County Water Utility General Notes.....	DC-B21

Appendix C - Sewer System Details

Typical Sewer Trench Section.....	DC-C01
Water Stop.....	DC-C02
Sanitary Sewer Manhole.....	DC-C03
Drop Manhole.....	DC-C04
Sanitary Sewer Manhole Raising.....	DC-C05
Typical Sewer Lateral.....	DC-C06
Sewer Lateral Clean Out.....	DC-C07
Sewer Service Saddle.....	DC-C08
Dumpster Pad Trench Drain System.....	DC-C09
Grease Interceptor.....	DC-C10

Appendix D - Storm Drainage Details

Typical Storm Drain Trench.....	DC-D01
Water Stop.....	DC-D02
Manholes for 15-inch to 24-inch.....	DC-D03
Manholes for 30-inch to 48-inch.....	DC-D04
Storm Drain Manhole Notes.....	DC-D05
Type 4R Curb Inlet and Grate.....	DC-D06
Access Control Rack.....	DC-D07
Trash Rack.....	DC-D10

Appendix E - Erosion Control Details

Reserved for Future Use

Appendix F - Acronyms, Abbreviations, and Definitions

Appendix G – Hillside Grading



Division 1 Introduction

DIVISION 1.0 INTRODUCTION

1.1 General

The purpose of this manual is to provide certain minimum standards for the design, construction, repair, and alterations of streets, roadways, alleys, drainage, grading, sewers, water supply facilities and all appurtenances thereto within Douglas County. The requirements herein, unless otherwise noted, apply to public and certain regulated private improvements (grading and drainage, private roads, floodplain development, etc.); see Chapter 20.830 and Chapter 20.840 of Title 20.

The requirements herein shall apply to the following:

1. Public Works Projects (by governments or utility purveyors)
2. Development Permits (zoning permits, land division permits, site improvement permits, encroachment permits, and building permits as defined in the Douglas County Development Code).
3. Master Plan Amendments

This manual is intended to cover normal situations encountered in design. Situations which are not covered in this manual shall be designed in accordance with accepted engineering practices, and shall be subject to the approval of the County Engineer. The County Engineer may authorize alternative designs to address situations that are not covered in this manual, provided that such designs are the equivalent of the design standards, are in accordance with accepted engineering practices, are not authorized for the purpose of mere convenience or economy, and provided that such designs are supported by a written engineering analysis and justification.

Complete plans for all improvements shall be submitted to the County for approval and must receive the required approval prior to the beginning of construction of such improvements. Executed copies of all public easements shall be provided prior to the issuance of a permit. The executed easement will not be recorded until after construction in the event the easement alignment changes. Copies of recorded private easements shall be provided to the County prior to Notice of Completion or Certificate of Occupancy. This shall apply to all projects within the County. Plans shall be stamped and signed by a Professional Engineer licensed in Nevada in compliance with NRS and NAC 625.

By reviewing and approving improvement plans, reports and other documents, neither the County nor the local entities assume liability for improper design, nor guarantee that the final design review and approval will absolve the developer, designer or engineer of future liability for improper design or construction.

1.2 Related Documents

All plans and documents requiring County approvals shall be prepared in accordance with the standards contained herein. Items which are not included in this manual shall be designed in accordance with the current adopted edition of the following publications:

1. Douglas County Development Code
2. International Building Code
3. International Residential Code

4. Standard Specifications for Public Works Construction, Sponsored and Distributed by Regional Transportation Commission of Washoe County, Washoe County, City of Sparks, City of Reno, Carson City, City of Yerington
5. Uniform Plumbing Code
6. International Fire Code
7. Uniform Mechanical Code
8. National Electric Code
9. Standard Details incorporated as Appendices A through E of this manual
10. Americans with Disability Act Accessibility Guidelines, also refer to <http://www.access-board.gov/prowac/nprm.htm>
11. Definitions incorporated as Appendix F of this manual
12. Manual of Uniform Traffic Control Devices
13. Green Construction Code (on a voluntary basis)

1.3 Variance Procedures

Variations to the standards and requirements of this manual may be requested only for the following reasons:

1. Situations where strict compliance with the manual may not act to protect public health and safety.
2. Situations which require additional analysis outside the scope of this manual for which the additional analysis shows that strict compliance with the manual may not act to protect public health and safety.
3. Hydrologic and/or hydraulics conditions which cannot be adequately addressed by strict compliance with the manual.

Conditions which are created by improper site planning (i.e. lack of adequate space allocations, financial hardship) shall not be considered grounds for a variance request.

If the developer (builder, subdivider, etc.) believes that a variance to the minimum standards in this manual is warranted based on the reasons listed above, the developer shall request in writing a variance from the minimum standards.

Variance from this manual shall be made in accordance with the procedures outlined in Douglas County Development Code. Plans that fully describe the variance, how it will function and perform, and impacts on surroundings along with an engineering based analysis and justification shall be submitted to the County before the County will consider a variance from this manual.

1.4 Interpretation and Conflict

In the interpretation and application of the provisions in this manual, the following shall govern:

1. The provisions of this manual shall be regarded as the **minimum** requirements for the protection of the public health, safety, comfort, convenience, general welfare, property, and commerce.

2. Whenever a provision of this manual and provisions of Douglas County Development Code or provisions of law, ordinance, resolution, rule, or regulation, contain restrictions covering the same subject matter, whichever restrictions are more restrictive or impose higher standards or requirements shall govern.
3. The County Engineer shall make the final determination as to the interpretation and application of the provisions of this manual.

1.5 Updates

This manual will be updated from time to time as determined by the Community Development Director. Respective entities have been afforded the opportunity to participate in the development of this manual and will be given the opportunity to also participate in subsequent updates.

1.6 Adoption

The Douglas County Board of Commissioners shall adopt the design standards manual and all subsequent updates thereto by resolution.

Updates to the standard details portion of the manual shall be updated by the Engineering Department on an as needed but not to exceed annual basis.

1.7 Compliance with Updates to this Manual

Updates to this manual shall be in effect 180 days after the update is adopted with the exceptions discussed below:

1. If a development is phased, updates to this manual shall apply to all phases for which final technical drainage studies (submitted via improvement plan review, a site improvement permit, or a building permit) have not been approved within 180 days of the date the update is adopted.
2. Projects for which permits have been issued shall comply with the provisions of the manual that was in effect the date the permit was issued, except if the permit has expired it shall be resubmitted for review and compliance to the updated manual.
3. Projects for which an improvement plan review, a site improvement permit, or a building permit have been submitted and deemed complete within 90 days of the date the update is adopted shall comply with the provisions of this manual in effect prior to date the update is adopted.



Division 2 Improvement Plans

DIVISION 2 IMPROVEMENT PLANS

2.1 General

All plans submitted to the County shall be on standard 24 inch by 36 inch sheets or 22 inch by 34 inch sheets, and be stapled. Proposed developments applying for a Site Improvement Permit (SIP or permit) may not obtain permits for grading, or any partial improvements until complete plans for the entire development or current phase of development are submitted to the County.

Margins shall be 1.5 inches on the left edge and 1 inch on the other three sides. Each sheet of the plans shall have a north arrow, scale (numeric and bar), and shall carry a title block which shall contain the name of the project, owner(s) and type of design shown on the plan; the Engineering firm's name, address, and telephone number; the name and stamp of the professional engineer licensed in Nevada, responsible for design, the date, sheet number and total number of sheets; and information necessary to clarify the design. The plans shall clearly indicate in plan and profile, the distinction between existing conditions and proposed improvements, and shall designate improvements as public or private. The plans shall show adjacent property owners.

The plans shall include a revision block on each sheet with revision number, date, initials of design engineer, description of plan changes, and spaces for County approval and date. All revisions within the plans shall be referenced on the title sheet.

2.2 Requirements

All plans shall conform to County Standards, and shall be complete, sealed, signed, and dated by a professional engineer where required, licensed in Nevada, and conform to the requirements of this manual and NRS and NAC 625 & 623, respectfully. Plans that are not complete and are not in conformance with County requirements will be returned without review. Douglas County requires all plans to place the "call before you dig" information stamp on all improvement plan sheets.

2.2.1 Title Sheet

The first sheet shall be a title sheet and include a location map and index map with the following information:

1. Location map:
 - a. Project location
 - b. Major cross streets
 - c. County, Town, or General Improvement District boundary lines if near the project
 - d. North arrow
 - e. Scale: 1" = 1000' (or as appropriate)
2. Index map:
 - a. Street configuration within the project
 - b. Lot configuration and numbers (include entire tentative tract or development)
 - c. Project boundaries

- d. Street names
 - e. Index of sheets
 - f. County, Town, or General Improvement District boundary lines if contiguous to project
 - g. North arrow
 - h. Scale: 1" = 200' (or as appropriate)
 - i. Section lines
3. Signature Blocks for the following:
 - a. County Engineer
 - b. General Improvement District (as required)
 - c. Town (as required)
 - d. Water Company (as required)
 - e. Sanitary (as required)
 - f. Fire Authority (as required)
 - g. State Agency (as required)
 - h. Project Owner (if private development)
 4. General Information
 - a. Basis of Bearing
 - b. Benchmark

2.2.2 Utility Index

A Utility Index will be required where significant amounts of infrastructure are planned, and a general overview of the whole improvements is desired. The Utility Index shall be a single sheet of the subdivision or development showing the general location of gas, electric and telephone lines and facilities, water, sanitary sewer and storm drain systems, identifying and numbering all manholes and structures and indicating improvements as either public or private as appropriate. The utility index shall include:

1. The location of the development in relationship to the surrounding area
2. All properties to be serviced by the water and/or sewer system
3. All existing and proposed water mains, sewer mains, irrigation facilities and storm drains serving the development and their respective sizes, and direction of flow
4. All valves, fire hydrants, blowoffs, manholes, lift stations, pump stations, etc.
5. All street rights-of-way and easements
6. All street names, lot lines and lot numbers, and property boundaries
7. The location of all wells within the boundaries of the development
8. Water service and sewer lateral locations
9. Gas line locations

10. Electrical line locations
11. Telephone and communication line locations
12. Cable line locations
13. Scale
14. North arrow

2.2.3 Right-of-Way and Easements

Right-of-way lines on both sides of all streets, the boundaries of lots fronting on both sides of all streets, drainage easements, utility easements, section lines and corners, land grant lines, slope easements, and temporary construction easements both existing and proposed shall be shown on the plans. All right-of-way and easement lines and widths shall be dimensioned and noted with the applicable recorded document number. Also refer to Division 9 Easements for further information.

2.2.4 Topography

All pertinent topographic features (existing and proposed) such as street lines, curbs, sidewalks, shoulders, location and size of sanitary sewers, storm drains, water, gas, electrical, telephone lines and other underground facilities shall be shown. Structures, houses, trees and other flora, drainage ditches, utility poles, fire hydrants, and all other features of the area which may affect the design shall also be shown.

Where proposed improvements meet existing infrastructure facilities, the plan shall show all pertinent existing elevations, gutter grades, center line of pavement, sewer and storm drain inverts and slopes, driveway locations, etc. for a minimum distance of 100 feet from the boundary or limits of the development.

When showing existing pavement or concrete in relation to new work, shading or delineation shall be made to identify new work from existing features.

2.2.5 Stationing and Orientation

Douglas County requires a positioning system to determine the location of publically maintained facilities and utilities. Design sheets shall conform to the following:

1. The origination point of all positioning systems shall be based on a known survey point or monument and identified on the plans;
2. The positioning systems shall be designed to proceed from south to north, west to east, left to right;
3. Plans shall be prepared so that north is to the top or right side of the sheets;
4. Design sheets shall be stationed in 100 foot intervals minimum; and
5. Where the proposed Public Works construction involves the installation or construction of more than one public utility and/or public street improvements, the horizontal control can be based on a monument line or centerline with appropriate stationing and offsets identified.

All street center lines, beginning of curves, points of compound curves, end of curves and limits of work shall be stationed on the plans. All existing and proposed utilities, right-of-way, curbs, edge of pavement, etc. shall be dimensioned from the centerline of roadway. Curve data shall include; centerline radius, length of curve, delta or central angle and tangent distance. Vertical curves shall include the length of the curve, begin vertical curve and end vertical curve stations and elevations, and the K-value used (rate of vertical curvature).

A Class A monument in accordance with the Standard Details shall be constructed at all public street intersections, beginning and end of horizontal curves, points of curvature, and angle points on all public roads.

2.2.6 Basis of Bearing and Bench Marks

All improvement plans shall include the following:

1. The horizontal survey control and basis-of-bearing for all improvement plans shall be the Nevada State Plane Coordinated System, West Zone, based on the North American Datum-1983/1994 (NAD 83/94). Survey control points used for the horizontal control shall be shown on the improvement plans together with the Modified State Plane Coordinate System coordinate values for these points. A basis-of-bearing statement identifying that the improvement plans are based on the Nevada state plane coordinated system, West Zone, (NAD 83/94), shall be included on the plans.
2. The North American Vertical Datum-1988 (NAVD88) shall be used for vertical control. Bench marks used for the vertical control shall be shown on the improvement plans together with the elevation of the bench mark(s). A bench mark statement identifying the bench mark or bench marks used for the improvement plans and the datum on which they are based shall be included on the plans.

2.2.7 Typical Section

A typical section(s) for each type of street within the area to be improved, delineating the structural features, width of right-of-way, improvement dimensions and details on both sides of all streets shall be a part of the plans. The typical section must include all utilities, including but not limited to: sewer, water, drainage, power, cable, phone, and gas.

2.2.8 Cross Sections

Cross sections shall be included in the plans for areas of significant cutting and/or filling when required by the Engineering Division.

2.2.9 Grading

The minimum acceptable standards for grading are presented in this section and in Appendix G Hillside Grading. Grading within the Tahoe Basin portion of Douglas County shall conform to the requirements of the Tahoe Regional Planning Agency and be approved by the Engineering Division.

Submittals are necessary to ensure that on-site drainage is adequately handled, that off-site drainage at ultimate development in accordance with the current master plan is conveyed through the project, and that the proposed development grading plans are compatible with adjacent property topography.

This section of the manual specifies the requirements of grading plans for improvements. It includes items pertinent for the County's review and reflects established professional engineering practice for preparation of grading plans. Grading plans shall be submitted to the County when required by the International Building Code or International Residential Code, for all commercial improvements and for all grading in the vicinity of a drainage channel, ditch, slough, river or a FEMA designated flood zone.

2.2.9.1 Grading Plan Requirements

Grading plans shall include the following as required:

1. Applicable General Notes. (See Table 2.1 below in this Division)
2. Legend and symbols.
3. Detail of typical lot drainage.
4. Reference to the Geotechnical Engineering Report and/or Engineering Geologist Report. This report must be in conformance with the requirements of Division 8 Geotechnical Engineering Reports.
5. The grading and drainage plan shall clearly delineate the grading of the project and shall include the following:
 - a. Location of drainage facilities;
 - b. Direction of drainage flow in each street;
 - c. Location of all existing buildings, structures, trees, cesspools, septic tanks, and wells on the property;
 - d. The location of buildings or structures or other significant features which may be impacted by the project;
 - e. All easements for drainage devices, roadways, and utilities with reference to the Record book, page, and document number;
 - f. Accurate contours and spot elevations indicating the topography of the existing ground and structures within the limits of the improvements and the surrounding areas. Contours shall be shown beyond the property line of the site being graded to properly indicate existing drainage patterns;
 - g. Finished grades by contours and/or spot elevations indicating proposed drainage patterns and grading, and for flow lines on valley gutters and spandrels. Show finished grade elevations at corners of all structures, curb returns, every 100 feet of profile, beginning of horizontal curves, ending of horizontal curves, beginning of vertical curves, ending of vertical curves, high and low points on vertical curves, and grade breaks. Pad and finished floor elevations shall be shown for final grading plans;
 - h. The location where all cuts and fills match existing ground shall be shown. The locations shall be shown continuous and obvious. The plans shall show the estimated quantities of cut and fill. A minimum setback of 2 feet shall be maintained from all cut or fill slopes to the property line;
 - i. Fill compaction and testing requirements;
 - j. Building or structure setbacks where known per approved site plan;
 - k. Limits of over excavation shown on plans matching Geotech report;
 - l. All drainage structures and reference to street or storm drain plans for construction details;
 - m. Location and complete details of detention basins;
 - n. Top and toe of all cut and fill slopes and setback from property boundary;
 - o. Location and complete details of subdrainage systems according to approved geotechnical report;

- p. Locations and reference to detail sheets for structural details of all walls, both retaining walls and free standing walls. Include the top of footing and top of wall elevations on the grading plans; and
- q. North arrow and scale, 1" = 40' minimum (include bar scale).

2.2.10 Grading Design Criteria

Grading shall conform to the International Building Code and the following requirements:

1. Minimum gradients:
 - Dirt, grass, etc. 2.0%
 - Asphalt concrete 1.0%
 - Hillside single family residential subdivision rear yard 2.0%
 - Rough graded hillside lots 2.0%
 - Terrace drains 4.0%
 - Interceptor drains 2.0%
 - Earth at rough grade stage 0.5%
 - Earth fine grade 1.0%
 - Portland cement concrete pavement (sheet flow) 1.0%
 - Portland cement concrete drain in earth area 0.5%
 - Portland cement concrete gutter in paved area 0.4%
3. Design for water to flow to nearest practical street, storm drain or natural watercourse. Provisions for the mitigation of cross lot drainage (i.e. lot line swales, ditches, or other drainage measures) shall be constructed for all lots one acres or less in size. Provisions to prevent surface drainage across lot lines shall be designed to convey runoff from the design storm.
4. Show design and location of all drainage structures and improvements necessary for development of the site.
5. Drainage shall not flow (sheet or concentrated) over the break of slopes.
6. Slopes:
 - a. Slopes shall be designed with full consideration of landscaping requirements. In right-of-way cut and fill slopes shall be no steeper than 2 horizontal to 1 vertical. On private property cut and fill slopes shall follow Geotechnical Report's recommendation.
 - b. Drainage shall be directed away from the faces of cut and fill slopes or into approved drainage structures. The faces of cut and fill slopes shall also be constructed to prevent erosion. This may consist of stepping or other surface protection such as erosion control blankets, vegetation, adding soil admixtures or other means. The protection for the slopes shall be installed within 15 days after completion of the rough grading.
 - c. Slopes to be planted shall be provided with an approved system of irrigation.

- d. Recommendations in the geotechnical report shall be incorporated into the design of slopes.
7. A surface area disturbance permit and general storm water discharge permit shall be obtained by the contractor in accordance with the requirements of the Nevada Division of Environmental Protection.

2.2.11 Erosion Control Design Criteria

2.2.11.1 General

Improvement plans shall show both temporary and permanent erosion control treatments. The plans shall indicate temporary erosion control treatments which are to be installed and maintained throughout construction until permanent erosion control measures are in place. The plans shall also indicate permanent erosion control treatments that are to be constructed as part of the project. In all areas of the County except the Lake Tahoe Basin, erosion control treatments shall comply with the Conservation Commission and Nevada Division of Environmental Protection "Handbook of Best Management Practices." In the Lake Tahoe Basin, erosion control treatments shall comply with the Tahoe Regional Planning Agency "Handbook of Best Management Practices."

2.2.11.2 Temporary Erosion Control Standards

Temporary erosion control treatments shall be shown on the improvement plans and comply with the National Point Discharge Elimination System permit requirements. Temporary erosion control treatments shall be installed within 15 days from the start of land disturbance activities, and shall provide for the following:

1. Temporary soil stabilization measures, such as erosion control blankets, shall be installed and maintained on graded slopes graded at 4:1 or steeper until permanent erosion control treatments are in place.
2. Temporary desilting facilities shall be provided at all drainage structure inlets and prior to discharge which leaves the area which is disturbed by the project, or enters a drainage, stream, creek, lake, or waterway. Desilting facilities shall be designed for a 25-year peak storm intensity. They shall be shown and detailed on the plans, and shall indicate the desilting facility volume based on gradient, inflow, and nature of soils. The plans shall indicate the size of desilting basin outlet pipe and outlet velocity. Outlet conditions from the desilting facilities shall not exceed downstream limitations. All desilting facilities shall have an overflow which is designed to safely pass 1.5 times the 25-year peak discharge.
3. Placement of devices to reduce erosion damage (i.e. temporary berm, check dams, hay or straw erosion checks, inlet sediment traps, etc.) within the area disturbed by the project shall be shown on the plans. Approved stockpile locations for materials shall also be indicated on the plans.
4. A construction entrance shall be installed prior to commencement of grading. Location of the entrance may be adjusted by the contractor to facilitate grading operations. All construction traffic which enters an existing paved road shall cross the construction entrance. The construction entrance shall consist of a bed of nominal 2 inch to 4 inch gravel no smaller than 15 feet wide, 30 feet long and 12 inch deep. The construction entrance shall be removed prior to placing base for paving.

2.2.11.3 Permanent Erosion Control Standards

The improvement plans shall incorporate facilities, structures, and treatments necessary to prevent erosion after completion of the project. Permanent erosion control treatments are required on all slopes steeper than 4:1 (horizontal to vertical). Mechanical or planted permanent slope stabilization may be used for permanent treatment.

Mechanical slope stabilization that consists of rock rip rap shall have a minimum layer thickness of 12 inches and 75 percent of the rock shall be 8 inches or greater in diameter. The rock shall contain a minimum of four fractured faces.

Planted slope stabilization shall consist of an erosion control blanket and ground cover plants or seeding. Erosion control blankets shall have a minimum life span of three years, and the County will require that planted slope stabilization be secured in the amount of the full value of the work for a minimum of two years after installation of the work or until vegetation is established.

Where required to establish vegetation, slopes to be planted shall also be irrigated with an electrically controlled automatic watering system designed to cover all portions of the slope. A minimum of head to head coverage shall be required. The irrigation system shall be installed with an approved backflow device. All planted slopes shall be irrigated by the developer until established as approved by the County.

Landscaping, planting, and irrigation plans shall be submitted with the improvement plans for slopes which are planted and/or irrigated. Landscape and irrigation plans shall be prepared and submitted in accordance with the requirements of the Douglas County Code.

2.2.12 Site Drainage

Drawings which show site drainage shall be included in the improvement plans. Refer to Division 6, Storm Drainage, for drainage plan requirements.

2.2.13 Plan and Profile Sheets

Plan sheets shall have a minimum scale of 1" = 40' horizontal and 1" = 2' vertical or as approved by the engineering division. A scale bar shall be included on each sheet. Plan and profile sheets shall show all utilities and improvements within the project area.

2.2.13.1 Streets and Access Roads

Plan and profile sheets for streets and access roads shall include the following as a minimum:

1. Name of street.
2. Plan Section: Show monuments, right-of-way width, improvements, traffic control devices, intersecting streets, center line stationing, horizontal curve data and stationing. Refer to Division 10 for Street Lighting and show locations of street lights as required. Indicate bench mark stationing and elevation. Show existing facilities. Show grade break stationing and elevations, lot numbers, easements, and assessor's parcel number. Show stationing, elevations and calculated slope of curb returns at tangent points and at 10 foot increments around the curb return. Refer to Division 3 Streets and Traffic for additional infrastructure requirements.
3. Profile Section: Show existing and proposed grades along center line including vertical curve elevations and data (including finished grade elevations at 25 foot intervals on vertical curves), and the station and elevations of intersecting streets. Show existing facilities.

2.2.13.2 Water Systems

Refer to Division 4 Water Systems for water system infrastructure requirements.

2.2.13.2.1 Water System Improvement Plans

After the hydraulic system model and Preliminary Engineering Report is approved, improvement plans shall be submitted to the County for all water system improvements including water mains, wells, pumping facilities, treatment facilities, buildings, storage tanks and appurtenant facilities. A design review of pump station buildings, and storage tanks, and a building permit are required.

Water system improvement plans shall also be submitted to the Nevada Division of Environmental Protection, Bureau of Safe Drinking Water prior to, or concurrently with submittal to the Engineering Division. County permits will not be issued until the Nevada Division of Environmental Protection, Bureau of Safe Drinking Water issues written approval of the improvement plans. A water system improvement checklist is included in Table 4.2 of Division 4.

Improvement plans shall provide complete design for the water system. Technical specifications for all water system improvements shall be submitted with the improvement plans. Technical specifications are required for all equipment and materials not specifically identified in Standard Specifications for Public Works Construction. Technical specifications shall define applicable materials, material classifications, reference standards, head/pressure requirements, efficiency(s), warranty(s), spare parts, installation methods/requirements, operational schemes, and other relevant information.

2.2.13.2.2 Improvement Plan Requirements

Improvement plans for water systems shall include the following as a minimum:

1. A plan and profile shall be provided for main extensions which clearly show all existing conditions and work to be performed. Water, sewer, storm drain and paving design may be combined on one set of plans.
2. Plans shall indicate phasing and shall include a street, utility, and sheet index map showing the location and stationing of all water, reclaimed water or sewer mains, manholes, valves, flush valve assemblies, air release valves, fire hydrants, and pumping facilities.
3. The location of existing and proposed ditches and storm drain facilities. Fire hydrants, water valves, air release valves and no other water system facilities shall be located within existing or proposed ditches.
4. Drawings and details necessary to describe and clarify the improvements. Relying on future shop or vendor drawings and submittals will not be acceptable or adequate for Douglas County review of the improvement plans.
5. Water service lateral and water service line sizes, curb and corporation stop sizes for the subdivision parcel map, and any development shall be shown with a call out note on each plan/profile sheet.
6. Plans shall indicate dimensions of rights-of-way and easements at least once on each plan/profile sheet.
7. Plans shall show all existing utilities, curb and gutter, sidewalk, paving, traffic signing, miscellaneous improvements and property lines. The plan shall clearly indicate, in plan and profile, the distinction between existing conditions and proposed improvements.

8. Plans shall indicate relocation or removal of existing improvements in conflict with the proposed improvements. Removal and replacement of curb and gutter, sidewalk, paving, signage or utilities shall be shown.
9. Plans shall indicate size and location, by dimension from street centerline or control line, of the proposed service lateral(s).
10. Plans shall include all details in conformance with the Standard Details and as necessary for construction, including replacement of existing improvements.
11. The design engineer shall submit plans to all public utilities for review for conflicts. The design engineer shall address all comments and conflicts prior to County approval of the plans. Plan revisions due to public utility comments shall be submitted to the Engineering Division for review and approval prior to County approval of the plans.
12. All plans shall be prepared, signed, and wet stamped by a professional engineer licensed in the State of Nevada.

2.2.13.3 Sanitary Sewers

Refer to Division 5 Sewer Systems, for sanitary sewer infrastructure requirements.

2.2.13.3.1 Sanitary Sewer Systems and Facilities Improvement Plans

Improvement plans for sewage collection systems and facilities must be reviewed and approved by the Engineering Division and the local entity which will accept and maintain the improvements.

2.2.13.3.2 Improvement Plan Requirements

Improvement plans for sewer main extensions and sewer laterals shall conform to the following requirements:

1. A plan and profile shall be provided for main extensions. Water, sewer, storm drain and paving design may be combined on one set of plans.
2. Plans shall indicate phasing and shall include a street, utility, and sheet index map showing the location of all water, reclaimed water or sewer mains, manholes, valves, flush valve assemblies, air release valves, fire hydrants, and pumping facilities.
3. Sewer service lateral sizes and water service line, curb and corporation stop sizes for the subdivision and parcel map development shall be shown by note on each plan/profile sheet.
4. Plans shall indicate dimensions of rights-of-way and easements at least once on each plan/profile sheet.
5. Plans shall indicate relocation or removal of existing improvements in conflict with the proposed improvements. Removal and replacement of curb and gutter, sidewalk, paving, signage or utilities shall be shown.
6. Plans shall indicate dimensions from street centerline or control line to all existing and proposed mains. Plans shall indicate invert elevation, size and location, by dimension from street centerline or control line, of the proposed sewer main and service lateral(s). All manholes and laterals shall be stationed and dimensioned from street centerline or control line. Manholes shall be numbered (i.e., A-1 is manhole #1 on line A).
7. Plans shall include all details in conformance with the Standard Details.

8. The design engineer shall submit plans to all public utilities for review for conflicts. The design engineer shall address comments received from the public utilities and identified conflicts prior to County approval of the plans. Plan revisions due to public utility comments shall be submitted to the Engineering Division for review and approval.
9. The design engineer shall submit plans to the Nevada Division of Environmental Protection prior to, or concurrently with submittal to the Engineering Division. County permits will not be issued until the Nevada Division of Environmental Protection issues written approval of the improvement plans.
10. All plans shall be prepared, signed, and wet stamped by a professional engineer licensed in the State of Nevada.

2.2.13.4 Storm Drains

Refer to Division 6 Storm Drainage for storm drain infrastructure requirements.

2.2.13.4.1 Improvement Plan Requirements

Both the drainage improvement plans and specifications shall be submitted to the Engineering Division for review. Approval of the final improvement plans by Douglas County shall be obtained prior to issuing a site improvement permit or building permit. Plans showing the drainage improvements shall include the following as a minimum:

1. Storm drains, inlets, outlets and manholes with stationing, elevations, dimensions, type and horizontal control indicated.
2. Provide profiles for public mains over 15 inch in size and laterals.
3. Culverts, end sections, and inlet/outlet protection with dimensions, type, elevations, and horizontal control indicated.
4. Channels, ditches, and swales (including side/rear yard swales) with lengths, widths, cross-sections, grades and erosion control (i.e. rip-rap, concrete, and grout) indicated.
5. Checks, channel drops, erosion control facilities and measures.
6. Detention pond grading, low flow channels, outlets, landscaping, fencing (as required), and maintenance access.
7. Other drainage related structures and facilities (including underdrains and sump pump lines).
8. Maintenance access locations and dimensions.
9. Permanent erosion and sedimentation control facilities (refer to Douglas County Hillside Development Ordinance).
10. Drainage easements and right-of-way with dimensions showing the distance to improvements.
11. Details for drainage structures, facilities, and improvements, including detention basin outlet control structures.
12. Temporary Construction Erosion and sedimentation control plan
13. Flood Hazard Zones

The information required for the plans shall be in accordance with sound engineering principles, this manual, the Standard Details, and the "Standards Specifications for Public Works Construction."

Construction documents shall include geometric, dimensional, structural, foundation, bedding, hydraulic, landscaping, specifications, and other details as needed to construct the drainage improvements. Improvement plans shall be signed and sealed by a professional engineer licensed in Nevada and be in accordance with the approved drainage report/drawings.

2.2.13.5 Electric, Telephone and Gas Utilities

Improvement plans should include the following:

1. Plan and profile sheets showing all proposed electric utilities including conduit, pads, boxes, vaults, and services.
2. Plan and profile sheets showing all proposed telephone utilities including conduit, boxes, vaults and services.
3. Plan and profile sheets showing all proposed gas lines and services.

2.2.13.6 Existing Utilities

Improvement plans shall show all existing utilities. In order to determine location and depth of existing utilities where proposed utilities will cross, existing utilities shall be potholed or the elevation shall be calculated based on manhole invert elevation. Pothole information shall be shown on the improvement plans. Gravity lines shall have manhole and catch basin inverts surveyed. Existing utilities shall be shown for a minimum distance of 100 feet from the boundary or limits of the development to the next gravity sewer and/or storm drain manhole.

2.2.13.7 Landscaping

Landscape plans shall be prepared and submitted in accordance with the requirements of the Douglas County Code. All landscape irrigation lines under pavement in public right-of-way or public easements shall have a minimum cover of 42 inches and shall be constructed of polyvinyl chloride (PVC) in conformance with AWWA C900 Standard for Polyvinyl Chloride (PVC) Pressure Pipe or polyethylene tubing. The Engineering Division may allow use of other landscape irrigation line materials, such as schedule 40 PVC, under pavement if they are installed in a steel conductor casing below the bottom of the structural pavement section. The County may allow other casing materials such as PVC with a dimension ratio (DR) of 35 or less, provided there is a minimum cover of 36 inches over the top of the casing pipe and the conductor casing color or markings are consistent with those used for water utilities.

The civil engineer is required to design and detail the landscape irrigation laterals from the water main to the water meter. The landscape architect may show improvements past the water meter.

2.2.13.8 Details

Standard Details to be used on the project shall be shown on the plans. Additional details as necessary for clarification of the improvements shall also be shown. Provide applicable general notes, including the following note on the plans:

All construction shall conform to the "Standard Specifications for Public Works Construction" and Douglas County Standards.

2.2.13.9 Record Drawings

Record drawings shall be submitted to the County prior to County acceptance of a subdivision, parcel map, development, utilities, facilities, or improvements. The record drawings shall show at a minimum the following items:

1. Station of all survey monuments
2. Elevations for TC and/or EP elevations at a minimum of every 300 feet and at all grade breaks;
3. As-built information of all Line and Curve Tables within the plans;
4. Ensure plans reflect all change orders and field directive conditions;
5. Flow line of drainage improvements, as applicable;
6. Rim and invert (both inlet and outlet) elevations on all storm drain manholes and pipe outlets/inlets;
7. Rim and invert (both inlet and outlet) elevations on all sewer manholes and pipe outlets/inlets;
8. Completed survey of detention/retention ponds constructed with volume proposed and actual volume constructed;
9. Elevations on spillways, weirs, and dams;
10. If the field elevation/invert matches the design elevation an "AB" for As-Built shall be marked next to the design elevation;

Record drawings shall be sealed by a Nevada Registered Land Surveyor. One full size set of plans shall be provided as record drawings. A digital copy of the record copies shall be provided with the PDF and DWG (or shape) files. The DWG files shall contain the line work for all constructed public utilities and road construction. These record drawings shall be rectified (geo-registered, tied to a grid based coordinate system) drawings with cross referenced drawings attached to the AutoCAD file. The consultant shall provide to the county the scale factor used to convert ground coordinates to grid coordinates.

2.2.14 Traffic Control Plans

Traffic Control plans shall be submitted to the County Inspector seven days prior to the start of construction for any work within the public right-of-way. The Traffic Control Plans shall be prepared by an American Traffic Safety Services Association (ATSSA) certified Traffic Control Supervisor. These plans may be submitted at the time of Site Improvement Permit submittal or Road Closure Permit submittal.

2.3 Permit Requirements

Refer to the Douglas County Development Code for permit requirements.

2.4 Changes in Plans

No changes in the design will be permitted after the plans have been approved unless written approval is given by the County and all other appropriate entities. Plans so changed shall be resubmitted to the County and all other appropriate entities for review. Changes made in the design without approval by the County may result in revocation of the construction permit (or other County-issued permit) and refusal by the County to accept the improvements.

If, during construction, changes in the plans are required due to field conditions, such changes shall be approved by the County and all other appropriate entities in writing, and the changes noted on the record drawings.

2.5 References

1. "International Building Code," International Code Council, Inc.
2. "International Residential Code," International Code Council, Inc.
3. Regional Transportation Commission of Washoe County, Washoe County, City of Sparks, City of Reno, Carson City, City of Yerington, "Standard Specifications for Public Works Construction."

Table 2.1. General Notes.

All applicable General Notes shall be included on any plan set submitted to the County.

Douglas County General Notes:

The following “General Notes” shall be included on all private land development projects that involve public improvements such as public streets, or Douglas County utilities and facilities.

1. All work and materials shall conform to the current Standard Specifications for Public Works Construction (“Orange Book”). All work and materials not in conformance with these amended specifications and details are subject to removal and replacement at the contractor’s expense.
2. One week prior to the commencement of any work, construction or installations associated with this permit, the Permittee shall notify the Douglas County Inspector at (775)782-6237 of intent to begin and request/schedule preconstruction meeting at the project site with Douglas County Construction Inspector. Failure to provide proper inspection notification as prescribed above shall result in this permit becoming invalid and work being stopped.
3. Contractor’s shall comply with the requirements to obtain the necessary Site Improvement Permits and shall comply with the Site Improvement Permit conditions as found on the back of the permit form.
4. The approved plan, permit and inspection record must be on the job site at all times.
5. Douglas County Parks and Recreation, Communications, and Sheriff’s Office is not represented by USA Digs. When the contractor excavates near or adjacent to any of these facilities/properties, the contractor shall contact the Administrator of applicable department at phone number shown on County website to request assistance in locating all their underground facilities. This requirement may also apply to any other County facility/property.
6. The contractor shall obtain a Stormwater General or a Surface Area Disturbance Permit from the Nevada Department of Environmental Protection as required, and shall comply with its requirements for dust control on all applicable projects.
7. The engineer hereby certifies as evidenced by a professional seal & signature, that all affected utility companies both public and private have been contacted. All existing and/or proposed utility lines and other related information have been transferred onto these plans. To the best of engineer’s knowledge and based on information from the utility company. The engineer also hereby certifies that all existing and/or proposed public right-of-way and easements have been correctly plotted and shown.
8. The engineer, or land surveyor of record shall certify upon completion of construction that all public improvements (water and sewer utilities, storm drainage, concrete, paving, street lights, etc.) have been installed at the locations and elevations shown on the approved plans. Any changes shall be reflected on “As-Built”/Record Drawings provided by the engineer to the County’s Engineering Division.
9. The registered engineer or land surveyor shall certify that the minimum horizontal and vertical separations between utilities within public right-of-way and easements have been maintained as required by law or policy.

10. The developer shall provide all construction staking for the project.
11. The developer or the engineer is responsible for arranging the relocation or removal of all utilities or facilities that are in conflict with the proposed public improvements. The contractor is responsible for coordinating the relocation of all utilities, power poles, irrigation dry-ups, resets removals by others, etc.
12. The contractors shall locate all utilities prior to excavation and avoid damage to same. Call 811 for USA Digs two working days prior to digging.
13. Contractors shall comply with the provisions for traffic control and barricading per the approved traffic control plans.
14. If a fire hydrant is needed to obtain construction water, the contractor shall obtain a fire hydrant meter from Douglas County Public Works or Applicable Water Purveyor and pay all applicable fees and charges.
15. If during the construction of a public facility, the contractor fails to or is unable to comply with a request to the Engineering Inspector, and it is necessary for County forces to do work that is normally the contractor's responsibility, the County shall be justified in billing the contractor. Each incident requiring work by County forces shall be covered by a separate billing at the current applicable rates.
16. The contractor is advised that damage to public services or systems as a result of this project shall be repaired by the contractor and inspected by the Engineering Inspector. Unless otherwise approved by the County, all repairs shall be done within 24 hours. The contractor is advised that any costs related to repair or replacement of damaged public services and systems as a result of contractor's activities shall be borne by the contractor.

Douglas County Public Street/Right-of-way Improvement Notes:

The following note(s) are required whenever the private land development project constructs, installs or modifies public street improvements. These notes are in addition to the general requirement notes.

1. The developer and the contractor are required to coordinate the placement or installation of driveways in order to avoid conflict with utility services.
2. All frames, covers, valve boxes, manholes, etc., shall be installed to finish grade or shall be adjusted to finish grade after placing of asphaltic surface course by the contractor per applicable Douglas County Standard Details
3. The contractor shall adjust all frames, covers, valve boxes, manholes, etc. that are located within the parkway area after final grading and installation of landscaping.
4. The street paving permittee/contractor is hereby notified that in the event that acceptance of the public street paving is delayed; one year or more after the pavement is installed, the permittee/contractor shall apply a seal coat to the pavement. Type of material and rate of application will be directed by the Douglas County Engineering Department.

5. A standard residential driveway approach shall be constructed to a maximum width of 24 feet unless special approval has been obtained.

Douglas County Water Utility Notes:

The following general note(s) are required whenever a private land development project constructs, installs or modifies the public water system. These notes are in addition to the General Requirement notes.

1. All public water main materials shall be per Section 203.06 (DIP) or 203.15 (PVC) of the Standard Specifications for Public Works Construction.
2. All new waterlines that require service disruption in order to connect to the County system shall require a daytime tie-in. The contractor shall complete all work necessary to restore utility service and fully open the tie-in area to vehicular traffic within the time frame allowed by the County Engineering Inspector.
3. The contractor shall install a temporary plug or valve on a section of new water line to test lines before connecting to the existing public water system where there is no water valve on the existing line.
4. Water line test shall be conducted so that existing water lines will not be included in the test of the new line.
5. The required backflow prevention assembly shall be a manufacturer and model designated in the current "List of Approved Backflow Prevention Assemblies" as published by the Foundation for Cross-Connection Control and Hydraulic Research, University of Southern California.
6. The backflow prevention assembly shall be tested and approved by a certified technician prior to the request for final inspection.
7. Water main shutdowns/interruption of service: Water utility approval is required forty-eight (48) hours prior to notification of customers. Commercial and residential customers shall both receive forty-eight (48) hours written notice of a shutdown, and special arrangements may have to be made to accommodate customer's operational needs. The water utility is responsible for the notification when work is performed by the water utility. The contractor is responsible in all other cases. A list shall be kept by the responsible party listing the date, time, and address of all persons notified. The person notified shall be included on the list for all commercial customers. The contractor will be subject to damage claims should they fail to notify customers or maintain documentation of notification of customers. The contractor shall not operate any existing water valves without authorization of the water utility.
8. All water services 2" or less shall be CTS, PE Pipe (AWWA Standard C901); Services 3" or greater shall be Class 150 C900 PVC or as specified on the plans.
9. Line separation must meet the provisions of NAC 445A.6715 through 445A.6718 in its entirety, NDEP's Vertical Crossing Summary, and be approved by State and Water Utility.

10. All hot taps are to be performed by a licensed contractor approved by the water utility. The contractor shall contact the water utility at least forty-eight (48) hours prior to scheduling hot tap date and time.
11. Water valve markers shall be blue carsonite utility marker (CRM-3066), 5'-2" with water utility's decal or approved equal. Place marker no more than five (5) feet from the valve or as directed by the water utility.
12. All water main and water service inspections must be completed prior to any certificate of occupancy or notice of completion by the water utility accepting improvements.

Douglas County Public Wastewater Utility Notes:

The following general notes are required whenever a private land development constructs, installs or modifies the public wastewater (sewer) system. These notes are in addition to the General Requirements notes.

1. Contractors shall verify all invert elevations before proceeding with the balance of the utility trenching.
2. Steps shall not be installed within the manhole.
3. All sewer mains and laterals in the right-of-way/easement shall be PVC SDR 35 unless otherwise noted.
4. Flexible transition couplings may be used when connecting sewer mains to existing sewer mains, model per sewer utility approval.
5. Sewer manhole markers shall be installed when manholes are located outside of the paved surface. Sewer manhole markers shall be green carsonite utility markers, 5'-2" with manhole decal (668-MH) or approved equal. Place markers within easement in close proximity to manhole or as directed by the sewer utility.
6. The contractor shall install a plug at the point of extension of a sewer main prior to the start of construction. The plug shall remain in place until all lines have been inspected, tested, cleaned, flushed, and accepted by the sewer utility.
7. Sewer lines shall be tested per section 336.06 of the Standard Specifications for Public Works Construction. An air pressure test and alignment test per the Douglas County Design Criteria and Standards, and a deflection test per Section 336.06 of the Standard Specifications for Public Works Construction shall be performed on all sewer lines.
8. All sewer mains shall have a color television inspection prior to acceptance by the sewer utility and prior to paving.

Douglas County Storm Drain Notes:

These notes are in addition to the General Requirement notes.

1. Manhole Materials and Construction shall conform to the requirements of Section 204 "Manholes and Catch Basins" of the Standard Specifications for Public Works Construction.

2. Portland cement concrete (P.C.C.) shall have the following characteristics: 4000 PSI minimum compressive strength @ 28 days, (curb and gutter transition only, all unexposed concrete may be 3000 PSI), min. 6 sacks of cement per cubic yard with a max. water/cement ratio of 0.45, air entrainment 6% \pm 1.5%, slump at 1 to 4 inches. All materials shall conform to Standard Specifications for Public Works Construction Section 202.
3. Reinforcing steel shall be grade 40 and 1.5 inches minimum clear cover.
4. All storm drain pipe and structures shall be cleaned of sediment and debris prior to issuance of a Notice of Completion or Certificate of Occupancy.
5. Frames and grates shall be matched to achieve a close tolerance fit, with minimal gaps, as approved by the storm drain utility.
6. Precast manholes sections, other than grade rings, shall be joined with flexible plastic gasket material such as Ram-nek or approved equal per manufacturer's recommendations.
7. Manholes located outside paved areas shall require all weather access roadway consisting of 6 inches Type 2, Class B Aggregate Base (conforming to the Standard Specifications for Public Works Construction Section 200.01.02) and storm drain manhole markers be installed. Storm Drain Manhole markers shall be green carsonite utility marker (CUM 375), 5'-2" with decal reading "Storm Drain Manhole". Place markers on easement line nearest to manhole or as directed by the storm drain utility.
8. Grates shall be placed outside of the pedestrian traveled way. Grate openings shall not exceed 0.5 inches in width or 4 inches in length. Grates shall be traffic rated and ADA compliant.

Douglas County Grading General Notes:

These notes are in addition to the General Requirement notes.

1. All work shall be done in accordance with the International Building Code, OSHA requirements for excavation, and special requirements of the permit. Violations will result in the stoppage of all work until the violation is corrected.
2. No work shall be started without first notifying the County Engineering Inspector at (775) 782-6237 at least 2 working days before work is commenced.
3. Slopes shall be no steeper than 2 horizontal to 1 vertical, or as determined by the Geotechnical Engineer and approved by the County.
4. All grading shall be in conformance with the approved Geotechnical report prepared by _____ dated _____.
5. Fills shall be placed in accordance with the requirements of the "Standard Specifications for Public Works Construction."
6. The Engineer of Record shall provide the county and all other appropriate entities with copies of all test results on a weekly basis and a bound report of the test results and inspection reports,

arranged in chronological order, at the completion of the project. The Engineer of Record shall provide the County with an opinion regarding the construction similar to the following:

Engineer's Opinion

I hereby certify that I am a licensed engineer in the State of Nevada. To the best of my knowledge, information and belief, the project was constructed in general conformance with the plans and specifications, and in my professional opinion, is in compliance with applicable laws, codes and ordinances.

7. Fill areas shall be cleared of all vegetation and debris, scarified, and be approved by the Engineer of Record prior to the placing of fill.
8. Protective measures and temporary drainage provisions shall be used to protect adjoining properties during construction of improvements.
9. Dust shall be controlled by the Contractor to the satisfaction of the County, and in accordance with the Air Quality Permit from the Nevada Division of Environmental Protection when required.
10. All streets shall be maintained free of dust and mud caused by grading operations. All operations shall comply with the requirements of the Stormwater Discharge Permit from the Nevada Division of Environmental Protection.
11. All cesspools, septic tanks, etc., to be abandoned shall be filled or removed in accordance with the State of Nevada Standards and certified by the Engineer of Record.
12. Existing wells to be abandoned shall be capped in accordance with the State of Nevada Division of Water Resources Regulations for Water Well and Related Drilling.
13. The Developer's Engineer or Surveyor shall set grade stakes for all drainage devices and the contractor shall obtain inspection before placing concrete.
14. Finished Grading will be completed and approved, and Slope Planting and Irrigation Systems installed before issuance of a certificate of occupancy.
15. No rock or similar material greater than 4" in diameter shall be placed in the fill unless recommendations for such placement have been submitted by the Geotechnical Engineer in advance and approved by the County.
15. The Geotechnical Engineer shall verify all grading including compaction requirements and the stability of slopes created, existing or remaining.
16. In the event of changes arising during construction, the developer's engineer shall be responsible for determining an acceptable solution and revising the plans for review and approval by the County. No changes in the design will be permitted unless written approval is given by the County.
17. Erosion Control:
 - a. In case of emergency call (insert name and telephone number of owner's responsible and authorized person).

- b. A standby crew for emergency work shall be available at all times. Necessary materials shall be available on-site and stockpiled at approved locations to facilitate rapid construction of temporary devices or to repair damaged erosion control measures.
- c. After a rainstorm, all silt and debris shall be removed from check berms and desilting facilities. Graded slope surface protection measures damaged during the rainstorm shall also be repaired.
- d. Fill slopes at the project perimeter must drain away from the top of the slope at the conclusion of each working day.
- e. A six-foot high perimeter fence or a 24-hour guard shall be posted on the site whenever the depth of water in a facility exceeds 18 inches.
- f. Stormwater shall be controlled by the Contractor to the satisfaction of the County and in accordance with the Nevada Division of Environmental Protection stormwater permit.
- g. Contractor shall place hydroseeding with temporary irrigation on all cut and fill slopes and all other disturbed areas unless otherwise directed by Douglas County.



Division 3 Streets and Traffic

DIVISION 3 STREETS AND TRAFFIC

3.1 General

All streets shall be improved and conform to the requirements of this manual.

3.2 Standards

Design and construction of streets and related improvements, including traffic control plans, shall conform to the current edition of the following:

1. “Guidelines for Urban Major Street Design,” by the Institute of Transportation Engineers.
2. “A Policy on Geometric Designs of Highways and Streets,” by the American Association of State Highway and Transportation Officials (AASHTO).
3. “Manual on Uniform Traffic Control Devices,” by the Federal Highway Administration.
4. “Guide for Development of New Bicycle Facilities,” by the American Association of State Highway and Transportation Officials.
5. “Standard Specifications for Public Works Construction,” by Regional Transportation, Commission of Washoe County, Washoe County, City of Sparks, City of Reno, Carson City, City of Yerington.
6. “Access Management System and Standards,” by the Nevada Department of Transportation.
7. “Standard Plans for Road and Bridge Construction,” by the Nevada Department of Transportation.
8. “Roundabouts: An Informational Guide” by the National Cooperative Highway Research Program in cooperation with U.S. Department of Transportation and Federal Highway Authority.
9. Americans with Disability Act Accessibility Guidelines, also refer to <http://www.access-board.gov/prowag/nprm.htm>
10. “Standard Highway Signs Manual” by the Federal Highway Administration.
11. “Roadside Design Guide,” by AASHTO

3.3 Street Widths and Alignment

Street alignments shall conform to the Douglas County Master Plan. Additional right-of-way shall be provided near intersections as required by the Community Development Department or County Engineering Division in order to facilitate turning movements. Refer to Appendix A for typical roadway cross sections.

The County may require streets with centerline offsets at intersections to be evaluated in the traffic study. All improvements shall be centered within the dedicated right-of-way or dedicated roadway easement.

Adjustments to the street widths, curb return radii, and other traffic calming techniques shall be considered when pedestrian safety and convenience are important. Traffic calming techniques will be considered on a case-by-case basis by the County Engineer.

3.4 Access (Revised 10/18/2018 2018R-056)

All developments must be connected to the County’s improved thoroughfare and road system by one or more access roads of such dimensions and location approved to the standards specified in this manual. All driveways and unpaved road sections connecting to a paved county roadway shall be constructed with a concrete or asphalt concrete driveway a minimum of 10 feet from edge of paved roadway. At least two means of ingress and egress to County standards shall be provided to serve a subdivision or development of more than 20 single family residences or units. Access onto all local streets shall comply with the provisions of this manual. Local road spacing shall not be less than 225 feet centerline to centerline. Alleys which access local roads shall comply with the residential driveway spacing requirements. Refer to other Divisions of this manual or County Code for other access requirements for specific facilities, for example Division 4.8.6 for access around a water tank.

Road spacing for intersections with arterial and collector roadways shall be as shown in Table 3.0:

Table 3.0 Road Spacing for Intersections with Arterial or Collector Roadways

Roadway Classification	Posted Speed (MPH)	Public Road Spacing
Major Arterial	45 or Below	.25 mile
	50 - 55	.50 mile
	Above 55	1 mile
Minor Arterial	45 or Below	.25 mile
	Above 45	.50 mile
Collector Road	35 or Below	660 feet
	Above 35	.25 mile

3.5 Right-of-Way and Easements

All necessary right-of-way or easement acquisition outside the boundaries of a subdivision or development, including agreements as to access, ownership and maintenance, shall be completed at the time of submittal of application for a development permit. Right-of-way widths shall not be less than shown in Table 3.1. Required right-of-way width is typically greater than shown in Table 3.1 to comply with the Douglas County Comprehensive Trail Plan.

Table 3.1. Minimum Right-of-Way Widths.

Functional Classification	Minimum Right-of-Way Width (feet)
Principal Arterial	80 ²
Minor Arterial	80
Rural Major Collector	80
Rural/Urban Minor Collector	80
Rural/Urban Local Roadway	60

Notes

1. In fill developments where adjoining right-of-way is established may conform to the established right-of-way upon approval of the County Engineer.
2. All existing principal arterial roadways in Douglas County are maintained under the jurisdiction of the Nevada Department of Transportation. Right-of-way for principal arterials shall be coordinated with the Nevada Department of Transportation and comply with their requirements.
3. On-street parking is not allowed on Collector/Arterial roads. Special circumstances may allow on street parking to be approved by the County Engineer. This shall include additional right-of-way and traffic safety measures.

In areas of possible fire hazards, as determined by the Fire Authority, unobstructed fire protection equipment access easements not less than 20 feet wide shall be dedicated from the public street to the subdivision or development boundary. Permanent emergency access shall be designed and constructed to comply with the requirements of Section 3.10.13 Emergency Access Roads. A fire access or emergency access easement is not a secondary means of access and cannot be used to waive or modify the requirements of this section.

Right-of-ways shall be cleared of all brush, trees, stumps, or other debris except that sound trees twelve inches or more in diameter may be left standing in accordance with the approved set of improvement plans.

All cul-de-sac streets must have the right-of-way necessary for the operation of the roadway including, but not limited to, roadside drainage, sidewalks and public utilities. The rights-of-way and physical improvements for cul-de-sac street must include a reverse transition curve to the point of tangency.

3.6 Streets Along Property Boundaries

Streets must not be located along property boundaries unless required by a County adopted street pattern or shown as a master plan street. A proposed access street lying along a boundary, which is within the development or off-site but within an easement already dedicated to the County, must be dedicated and constructed full width to County standards, including curb, gutter and sidewalk. A proposed street lying along the boundary of a development or subdivision, which is within the development or is off-site within an easement dedicated to the County, that is impacted by that subdivision or development must be dedicated and constructed by that subdivision or development. If the proposed street, which is in the development or subdivision, does not offset any of the traffic of the development but is shown on the master plan or County adopted street pattern the street must be dedicated.

3.7 Half Streets

Half streets are not permitted on local roads. Along property boundaries half streets may be constructed for collector and arterial roadways which are designated on the Transportation Master Plan. Half street approval shall be considered on a case by case basis as approved by the County Engineer. Half streets shall provide a minimum of 22-feet of paved vehicular access plus a bike lane if necessary.

3.8 Pavement Sections

All road pavement sections shall be based on subgrade strength values determined by Resilient Modulus (MR) Value or Resistance (R) Value as shown in the geotechnical engineering report. Refer to Division 8 - Geotechnical Engineering Reports for requirements for the geotechnical report. As a minimum, pavement sections shall conform to the requirements of this manual.

3.9 Design Requirements

Streets shall be designed and constructed in accordance with the requirements of this section and the requirements of the Douglas County Development Code.

3.9.1 Street Grades

Streets within hillside areas shall be designed and constructed in accordance with requirements of Appendix G Hillside Grading. The following criteria shall apply to street grades that are not in hillside areas:

1. Minimum longitudinal grade shall be 0.50 percent.
2. Principal arterials, minor arterials, rural/urban major collectors, and rural/urban minor collectors shall have a maximum grade of 6.0%.
3. Local roadways shall have a maximum grade of 12%.
4. Grades in excess of 8.0% shall be limited to a horizontal tangent length of 400 feet. Grades in excess of 10.0% shall be limited to a horizontal tangent length of 200 feet.
5. Street intersections shall not be allowed when the grade on the primary street exceeds 6.0%.
6. “Roller-coaster” and “Hidden-dip” patterns are not allowed.
7. Sharp horizontal curvature shall not be introduced at or near the top of a pronounced crest vertical curve or near the bottom of a pronounced sag vertical curve.

3.9.2 Street Intersection

Street grades on the minor legs of intersections shall not exceed 4% for a minimum distance of 50 feet measured from the extension of the face of curb or edge of pavement of the primary street from the intersection (improved to full County standards). Additional criteria are as follows:

1. Street intersections of two local streets with a stop condition at all corners do not require a vertical curve at the intersection of the crown section with the street grade.
2. Design of street intersections shall meet American for Disabilities Act (ADA) Guidelines and Public Right-of-Way Accessibility Guidelines (PROWAG).
3. Other street intersections shall require a vertical transition at the intersection of the crown section with the street grade.
4. Whenever a street or highway is proposed requiring a separation of grades or special form of intersection design, the improvements shall be designed to provide for the intersection design, and all lots or building sites shall be practical and conform to the requirements for grading plans.
5. Intersection sight distance (a clear sight triangle) shall be maintained at each corner created by the intersection of two streets, or the intersection of a driveway with a street. The intersection sight distance is defined in the AASHTO “A policy on Geometric Design of Highways and Streets.” Additional dedication of right-of-way or easements may be required over the clear sight triangle.. Also refer to Planning Design Criteria Divisions 2.1.10 and 5.1.7.

Objects narrower than 4 inches in diameter, such as sign posts, are exempt from the clear sight area requirements, but no visual encroachment higher than 3 feet or lower than 8 feet will be allowed in the clear sight triangle. Where there are existing topographical features, buildings, or other fixed objects that cannot be removed to meet the minimum intersection sight distance requirements, the Engineering Division may allow the minimum stopping sight distance requirements in accordance with AASHTO “A Policy on Geometric Design of Highways and Streets” as an absolute minimum provided there are no

other intersection locations where greater sight distance can be obtained.

3.9.3 Street Crown

The normal street crown shall be 2.0% from the centerline to the lip of gutter, with a minimum of 1.0% and a maximum of 4% in non-crosswalk areas. The crown shall be at the centerline of the traveled way. Inverted crowns are not permitted on public roadways.

3.9.4 Vertical Curves

Vertical curves shall be provided wherever the algebraic difference between two intersecting grades is 2% or more, excluding intersections. Vertical curves shall be of sufficient length to provide the minimum sight and stopping distances as established by AASHTO.

3.9.5 Horizontal Curves

Horizontal curve radii, sight distances and maximum allowable side friction shall be determined in accordance with the requirements of "A Policy on Geometric Designs of Highways and Streets," by AASHTO. In no case shall the centerline curve radius be less than 150 feet. Maximum allowable superelevation (e_{max}) shall be four (4) percent. In urban areas, superelevation will not be allowed and horizontal curves shall be designed using a -2 percent crown.

3.9.6 Broken-Back Curves

Broken-back curves (having a short tangent between two curves in the same direction) shall not be allowed. A compound curve alignment shall be used to eliminate the need for a short tangent section between curves, or a minimum tangent section of 100 feet between curves shall be used. Design of compound curves shall comply with "A Policy on Geometric Designs of Highways and Streets," by AASHTO.

3.9.7 Median Openings

Median openings on arterial streets that have continuous raised center medians will not be allowed unless **all** of the following conditions exist:

1. The property to be served is a major traffic generator and has a minimum continuous frontage of 600 feet along the major street or, access easements are recorded to allow use of the opening by a minimum of two properties which combined generate sufficient traffic to warrant the opening.
2. The median opening is not less than 700 feet from an intersection with an arterial street.
3. The median opening is not less than 400 feet from an intersection with a collector or local roadway.
4. The median opening is not less than 600 feet from other existing or planned mid-block median openings.
5. Sight distance is adequate for the design speed of the major street.
6. All costs such as base material, pavements, safety lighting, traffic signals, reconstruction or utility relocation required by a mid-block opening shall be borne by the requesting party.
7. The design of median openings shall be subject to the requirements and approval of the Engineering Division including storage lengths and tapers to NDOT Access Management System and Standards.

8. The roadway governing authority agrees to maintain the median opening.

3.9.8 Intersection Angles

A street or highway intersecting with another street or highway, shall intersect as near to a 90 degree angle as is practicable, but in no event shall an intersection be allowed at an angle of less than 60 degrees.

3.9.9 Private Streets

Construction of new private streets shall meet County minimum structural section standards for local streets. Water systems, and sanitary sewer systems located within a private street shall be constructed to County standards and shall be supported by separate public utility easements. At the intersection with public streets, a standard size and design traffic sign shall be installed which says “PRIVATE STREET NOT MAINTAINED BY COUNTY.”

3.9.10 Asphalt Concrete Structural Sections

Design of the structural section for asphalt concrete pavement shall conform to the current edition of the AASHTO “Guide for Design of Pavement Structures.” Inputs to the design procedure shall be developed in accordance with the following:

1. Roadbed Soil. Roadbed soil testing shall be performed to determine the design roadbed soil resilient modulus, M_r , for use in the design charts. The design roadbed soil resilient modulus, M_r , shall be determined from the resilient modulus test or correlated with test results from the Resistance (R) Value test. Correlations between resilient modulus, M_r , and the Resistance (R) Value shall be in accordance with the AASHTO “Guide for Design of Pavement Structures” for Resistance (R) Values less than 20, or Figure 6.2 of the Nevada Department of Transportation Pavement Structural Design and Policy Manual.

Sufficient tests shall be made to evaluate each different soil type in the project. If significant roadbed soil variation is present, sufficient tests shall be made to determine the controlling (weakest) soil type, or the limits and boundaries of each roadbed soil type. The minimum number of R-value test and maximum spacing between tests are as follows:

Design Traffic Level Cumulative ESAL’s Over the Design Period	Minimum No. of R-Value Tests per Soil Type	Maximum Spacing for R-Value Tests along Roadway Alignment (feet)
< 10,000	1	1,000
10,000 to 1,000,000	3	750 ¹
> 1,000,000	3	500 ¹

Notes:

1. R-value tests may be spaced further apart if the project does not have significant earthwork or structures and a geotechnical investigation confirms the presence of uniform subsurface conditions. In all cases a minimum of three R-value tests per mile or three within the project boundary are required.

The design roadbed soil resilient modulus, M_r , shall be based on the results of R Value tests, and shall be determined as a function of the design traffic level, using lower design values when higher traffic levels exist. Percentile design values (select the design modulus such that X percent of all test values are less than the design modulus) for various traffic levels shall not be less than the following:

Design Traffic Level Cumulative ESAL's Over the Design Period	Minimum Percentile Design Value (X)
< 10,000	N.A.
10,000 to 1,000,000	75
> 1,000,000	87.5

If a subbase material is used, the material shall have a minimum R-value of 40; tests shall be conducted during construction to demonstrate compliance with the minimum R-value.

Thickness design of the subbase shall be in accordance with the AASHTO "Guide for Design of Pavement Structures," current edition using a layer coefficient of 0.07 or less for the subbase material, along with the design roadbed soil resilient modulus for the underlying native subgrade. The R-value of the subbase material shall not be used as the design roadbed soil resilient modulus.

For all pavement sections, an AASHTO M288 Class 1 or Class 2 heavyweight woven geotextile separator shall be placed immediately below base material when any of the following conditions exist:

- a. the subgrade R-value is less than 30
 - b. the subgrade has a plasticity index greater than 12
 - c. the underlying subgrade soil is classified as Pt, OH, CH, OL, CL, MH
2. **Traffic.** Site specific traffic data or projections shall be used to determine the number of equivalent 18,000 pound equivalent single axle load (ESAL) applications for the design period. The vehicle types and volumes shall be based on the results of a traffic study and shall include construction vehicles that will traffic the roadway during construction of the development or project. ESAL factors shall be selected from Table 3.3 or the current 18 kip equivalent axle load templates from the Nevada Department of Transportation. An annual growth rate of not less than 4 percent shall be used for the design period unless the roadway is a cul-de-sac or is within a closed service area with no potential for future growth. Design period shall be 20 years.

The worksheet for calculating 18,000 pound ESAL's and the traffic growth rates shown in Tables 3.2 and 3.4 respectively shall be used to determine the design ESAL applications. For local roads, if the calculated design ESAL based on site specific data or projections is less than 10,000, a minimum design ESAL of 10,000 shall be used. For collector roads, if the calculated design ESAL based on site specific data or projections is less than 50,000, a minimum design ESAL of 50,000 shall be used. Generic traffic estimates or guidelines for estimating ESAL's based on roadway classification shall not be used.

Site specific traffic data or projections are not required for local roadways that serve less than 10 residential units. These roadways may be designed using a design ESAL of not less than 10,000.

Table 3.2. Example Table for Calculating Design ESAL by Vehicle Class (7).

Location _____ Analysis Period = _____ Years
Average Annual Daily Traffic (AADT) Base Year = _____ (use current traffic counts)

Vehicle Types	Percent of Total (A)	Current Traffic (B)	Growth Factors (C)	Design Traffic (D)	Percent Trucks in Design Lane (E)	Directional Distribution (F)	ESAL Factor (G)	Design ESAL (H)
Passenger Cars								
Buses								
Single Unit Truck, 2 Axle, 6 Tire								
Single Unit Truck, 3 Axle or More								
Single Trailer Units, 4 Axle or Less								
Single Trailer Units, 5 Axle								
Single Trailer Units, 6 Axle or More								
Multi-Trailer Trucks, 5 Axle or Less								
Multi-Trailer Trucks, 6 Axle								
Multi-Trailer Trucks, 7 Axle or More								
<i>All Vehicles</i>							<i>Design ESAL</i>	

Notes:

1. Average Annual Daily Traffic is the two-way vehicle count for the base year.
2. Column A is the percentage of each vehicle type based on data collected at classification count stations for the base year. If classification data is not available, use the vehicle distribution data shown in Table 3.3.
3. Column B is the product of Vehicle Percent of Total (Column A) times the Average Annual Daily Traffic Volume for the base year.
4. Column C contains the growth factor assigned to each class of vehicle as taken from Table 3.4. This accounts for the fact that not all vehicles will increase at the same rate.

5. Column D is the product of Column B times Column C multiplied by 365 days to produce the accumulated applications of specific vehicle types during the analysis period.
6. Column E is the percent trucks in the design lane. For one lane in each direction, the percent trucks in the design lane is 100. For two lanes in each direction, the percent trucks in the design lane is 90. For three lanes in each direction, the percent trucks in the design lane is 70.
7. Column F is the traffic directional distribution of AADT based on collected data for the base year. If vehicle counts are the same in both directions of travel, the directional distribution is 0.5.
8. Column G is the individual ESAL factor for each vehicle type from Table 3.3.
9. Column H is the product of Column D x Column E x Column F x Column G to produce the design ESAL for each vehicle type.

Table 3.3. Vehicle Distribution and Average ESAL's (Flexible Pavements).

Percent of Travel										
Functional Classification	Passenger Cars	Buses	Single-Unit Trucks		Single-Trailer Units			Multi-Trailer Trucks		
			2 Axle, 6 Tire	3 Axle or More	4 Axle or Less	5 Axle	6 Axle or More	5 Axle or Less	6 Axle or More	7 Axle or More
Rural¹										
Principal Arterial	79.44%	0.59%	4.19%	0.59%	1.04%	11.55%	0.33%	0.65%	0.22%	1.40%
ESAL by Vehicle Group	0.0004	0.665	0.177	0.624	0.692	1.225	1.188	1.369	1.013	1.617
Minor Arterial	83.92%	0.47%	3.74%	0.73%	0.86%	8.04%	0.25%	0.61%	0.12%	1.26%
ESAL by Vehicle Group	0.0004	0.593	0.299	0.601	0.480	1.180	0.892	2.943	0.000	2.226
Major Collector	87.32%	0.33%	3.60%	0.70%	0.69%	5.22%	0.28%	0.43%	0.11%	1.32%
ESAL by Vehicle Group	0.0004	0.564	0.308	0.772	0.581	1.385	1.069	1.944	0.957	1.427
Minor Collector	95.40%	0.12%	1.46%	0.37%	0.20%	1.00%	0.16%	0.08%	0.03%	1.18%
ESAL by Vehicle Group	ESAL by Vehicle Group not available for minor collector road classification. Use 1.00 ESAL/Truck for minor collector roads.									
Local	93.53%	0.77%	3.45%	0.16%	0.11%	1.42%	0.00%	0.08%	0.03%	0.45%
ESAL by Vehicle Group	ESAL by Vehicle Group not available for local road classification. Use 1.00 ESAL/Truck for rural local roads.									
Urban²¹										
Principal Arterial	94.51%	0.55	1.85%	0.46%	0.48%	1.53%	0.10%	0.17%	0.10%	0.25%
ESAL by Vehicle Group	0.0004	1.212	0.293	0.939	1.325	1.249	1.295	2.678	0.941	1.873
Minor Arterial and Major Collector	95.73%	0.40%	1.72%	0.47%	0.41%	0.79%	0.04%	0.12%	0.06%	0.26%
ESAL by Vehicle Group	0.0004	0.767	0.222	0.851	0.639	1.210	1.236	2.016	0.678	1.850
Minor Collector	97.66%	0.20%	1.17%	0.13%	0.34%	0.09%	0.02%	0.23%	0.09%	0.07%
ESAL by Vehicle Group	ESAL by Vehicle Group not available for minor collector road classification. Use 0.66 ESAL/Truck for minor collector roads.									
Local	95.49%	0.38%	2.93%	0.55%	0.04%	0.46%	0.03%	0.01%	0.01%	0.10%
ESAL by Vehicle Group	ESAL by Vehicle Group not available for local road classification. Use 0.66 ESAL/Truck for urban local roads.									

Notes:

1. NDOT Vehicle Distribution and Average ESAL's by Roadway Classification, 05/02/2006. Current versions of this data shall be used when available.

Table 3.4. Traffic Growth Factors (7).

Analysis Period Years (n)	Annual Growth Rate, Percent (g)							
	No Growth	2	4	5	6	7	8	10
1	1.0	1.0	1.0	1.0	1.0	1.0	1.0	1.0
2	2.0	2.02	2.04	2.05	2.06	2.07	2.08	2.10
3	3.0	3.06	3.12	3.15	3.18	3.21	3.25	3.31
4	4.0	4.12	4.25	4.31	4.37	4.44	4.51	4.64
5	5.0	5.20	5.42	5.53	5.64	5.75	5.87	6.11
6	6.0	6.31	6.63	6.80	6.98	7.15	7.34	7.72
7	7.0	7.43	7.90	8.14	8.39	8.65	8.92	9.49
8	8.0	8.58	9.21	9.55	9.90	10.26	10.64	11.44
9	9.0	9.75	10.58	11.03	11.49	11.98	12.49	13.58
10	10.0	10.95	12.01	12.58	13.18	13.82	14.49	15.94
11	11.0	12.17	13.49	14.21	14.97	15.78	16.65	18.53
12	12.0	13.41	15.03	15.92	16.87	17.89	18.98	21.38
13	13.0	14.68	16.63	17.71	18.88	20.14	21.50	24.52
14	14.0	15.97	18.29	19.16	21.01	22.55	24.21	27.97
15	15.0	17.29	20.02	21.58	23.28	25.13	27.15	31.77
16	16.0	18.64	21.82	23.66	25.67	27.89	30.32	35.95
17	17.0	20.01	23.70	25.84	28.21	30.84	33.75	40.55
18	18.0	21.41	25.65	28.13	30.91	34.00	37.45	45.60
19	19.0	22.84	27.67	30.54	33.76	37.38	41.45	51.16
20	20.0	24.30	29.78	33.06	36.79	41.00	45.76	57.28
25	25.0	32.03	41.65	47.73	54.86	63.25	73.11	98.35
30	30.0	40.57	56.08	66.44	79.06	94.46	113.28	164.49
35	35.0	49.99	73.65	90.32	111.43	138.24	172.32	271.02

Notes:

- Factor = $\frac{(1 + g)^n - 1}{g}$, where $g = \frac{\text{rate}}{100}$ and is not zero. If annual growth rate is zero, the growth factor is equal to the analysis period.
- The above growth factors multiplied by the first year traffic estimate will give the total volume of traffic expected during the analysis period.

3. Thickness Design. Thickness design of asphalt concrete pavements shall be based on the AASHTO “Guide for Design of Pavement Structures,” current edition. Level of reliability shall be 70 percent for local roads and 85 percent for collectors and arterials. Design serviceability loss shall be 2.0 for all roads. In no case shall the structural section for asphalt concrete pavements be less than that shown in Table 3.5. A layered analysis shall be used to determine thicknesses of layers, including the asphalt concrete layer. The following design inputs shall be used:
 - a. Design Life = 20 years
 - b. Reliability = 85% ($Z_R = -1.037$) collector and arterial roads
= 70% ($Z_R = -0.524$) local roads
 - c. S_o = 0.45 (overall standard error)
 - d. ΔPSI = 2.0 (allowable serviceability loss)
 - e. m_i = 0.80 or less (drainage coefficient for base and subbase)
 - f. a_i = 0.35 or less (all plantmix asphalt, including PG 64-28 NV)
= 0.10 or less (Type2 Class B base material)
= 0.07 or less (subbase material)

4. Material Determination. Asphalt concrete pavement mix shall be Type 2 or Type 3 as shown in Table 3.5 in conformance with the “Standard Specifications for Public Works Construction.” Performance Grade 64-28 NV asphalt cement shall be used for all pavement mixes.

Table 3.5. Type of Asphalt Concrete Pavement Required.

Functional Classification	Type of Asphalt Concrete Pavement	Minimum AC Thickness (inches)	Minimum Base Thickness (inches)
Principal Arterial	N.A. ¹	N.A. ¹	N.A. ¹
Minor Arterial	Type 3 over Type 2	4	8
Rural/Urban Major Collector	Type 3 over Type 2	4	8
Rural/Urban Minor Collector	Type 3 over Type 2	4	8
Rural/Urban Local Roadway	Type 3 over Type 2 ²	3	6

Notes

1. All existing principal arterial roadways in Douglas County are maintained under the jurisdiction of the Nevada Department of Transportation. Design of principal arterials shall be coordinated with the Nevada Department of Transportation and comply with their requirements.
2. If local road section design is 4 inches, than top pavement lift shall by 2 inches of Type 3 mix over 2 inches Type 2 mix.

3.9.11. Knuckles/Hammerheads

Knuckles and hammerheads shall conform to Douglas County Development Code and Fire Code Requirements. Shared driveways may be terminated in a knuckle/hammerhead.

Minimum grades around Knuckle-type intersections shall be 0.5%. The normal street crown with such a development may be increased to a maximum of 4.0% from the centerline to the lip of gutter.

One sidewalk ramp shall be installed across from another at or near the ends of the outside returns on one side of the knuckle.

3.9.12 Cul-De-Sacs and Dead End Streets

All cul-de-sacs and dead end streets shall comply with the current adopted International Fire Code and this design manual. The minimum lot frontage on cul-de-sac streets shall be 36 feet, and meet ADA requirements. "Dead End" signs shall be posted on cul-de-sacs with length greater than 100 feet. The developer shall be responsible for posting a sign at the terminus of temporarily dead-ended right-of-way indicating that the right-of-way is intended to be extended in the future. Dead end streets exceeding 150 feet in length when measured from the roadway right-of-way to the end of the street, or which is more than one lot depth, shall be provided with a cul-de-sac. Minimum grades around cul-de-sac type intersection shall be 0.5%. The normal street crown with such a development may be increased to a maximum of 4% from the centerline to the lip of gutter.

A temporary cul-de-sac may be provided with a phased development where continuation of the roadway is anticipated. All residential cul-de-sacs and temporary cul-de-sacs shall have a 50 foot radius bulb when measured from the radius point to face of curb or edge of pavement. All cul-de-sacs and temporary cul-de-sacs for commercial or industrial roads shall be 55 feet when measured from the radius point to the face of curb or edge of pavement where no curb is present. Right of way or easements that encompass improvements shall be provided by the developer.

Streets shall be extended to the subdivision/development boundary for future development. Where subdivisions are phased, streets shall be extended to the subdivision phase boundary line. Streets extending to the subdivision or development boundary which are proposed for future extension and exceed 150 feet in length or more than one lot in depth shall be provided with temporary cul-de-sacs. The future removal of the cul-de-sac and its replacement to full width County standard street improvements shall be provided with the extension of the street by future development. Right-of-way or easements shall be provided by the developer for the temporary cul-de-sac.

A total of three ADA ramps shall be installed at each Cul-de-sac, one at each of the returns and one at the opposite side of the street to one of the returns.

3.9.13 Emergency Access Roads

Permanent and temporary emergency access roadways shall have a minimum width of 20 feet. Grades shall not exceed the maximum street grades. Access to roadway at each entrance shall be controlled by an emergency access control gate, and shall be posted "For Emergency Vehicles Only."

Temporary and permanent emergency access roads shall be structurally designed to support a tandem axle loading of 37.5 tons. In no case shall **temporary emergency access roads** be surfaced with less than four inches (4") of Type 2, Class B Aggregate Base applied with a minimum 0.5 gallons per square yard of magnesium chloride and be provided with adequate roadside drainage. In no case shall **permanent emergency access roads** be paved with less than three inches (3") of asphalt concrete pavement on six inches (6") of aggregate base. Emergency access roads shall be provided with adequate roadside drainage.

3.9.14 Improved Maintenance Access

Vehicular access for maintenance of sanitary sewer, water system, and storm drain facilities and their related appurtenances shall be constructed to a minimum width of 12 feet, be provided with adequate roadside drainage, and with an alignment to minimize grades but in no case shall grades exceed 12% or as allowed in Appendix G Hillside Grading when applicable.

Temporary and permanent maintenance access shall be structurally designed to support a tandem axle loading of 40 tons. In no case shall temporary maintenance access roads be surfaced with less than 6 inches of Type 2, Class B aggregate base

In no case shall permanent maintenance access roads for publicly owned facilities be paved with less than 3 inches of Type 2 or Type 3 asphalt concrete pavement on 6 inches of aggregate base, or as approved by utility.

3.9.15 Retaining Walls

All retaining walls, including rockery walls, constructed within the public right-of-way shall have a complete set of design calculations submitted to the County with the improvement plans. All calculations shall be signed and sealed by a professional engineer licensed in Nevada. Retaining walls constructed on public and private property shall be reviewed by the Douglas County Building Division and shall be subject to their design criteria. A Douglas County Building Permit shall be obtained for all retaining walls that are greater than 4 feet in height measured from the bottom of the footing to the top of wall. If retaining walls, including rockery walls, are included on plans submitted for a site improvement permit, a special inspection agreement with the Douglas County Building Division shall also be submitted.

3.9.16 Signs

Street name signs shall be installed at all intersections. Guide posts (hazard markers/snow markers) and hazardous condition signs shall be installed to mark obstructions within or adjacent to the arterial or collector roadway clear zone, including the medians for those roads. The clear zone shall have a minimum width of 10 feet beyond the edge of pavement where no curb is present and 2 feet beyond the face of curb. Signage shall be installed on all newly constructed or improved public streets within or adjacent to the development, as required by approved improvement plans. Signs and pavement markings shall conform with the MUTCD, and the Standard Street Sign detail in Appendix A. Snow markers are required for projects within the Lake Tahoe Basin. Stop signs shall be a minimum of thirty inches (30”) in size. All street, traffic control, and hazard signs shall be constructed of Type III (High Intensity Prismatic Material) reflective sheeting as specified in Section 716 of the Nevada Department of Transportation Standard Specifications for Road and Bridge Construction.

Proposed signage layouts shall be submitted with public improvement plans. A list of traffic signs and regulatory traffic control devices installed as part of the project, and the background information for the devices (i.e. traffic study, speed study, etc.) shall be submitted with the improvement plans. The list of traffic control devices shall be submitted in the format shown in Table 3.6.

3.9.17 Pavement Markings

Pavement markings shall be installed for all improvements in accordance with the recommendations of the traffic report, or as required by the approved improvement plans. Proposed pavement marking layouts shall be included in the improvement plans. Crosswalk markings shall be installed at all traffic signal locations, at other locations as recommended in the traffic report, and at other areas required by the County such as schools, parks, and areas of high pedestrian activity. “Continental” style crosswalk markings shall be used at all crosswalk locations unless stamped concrete or pavers have been installed,

in which case “Standard” style crosswalk markings shall be provided to eliminate painting the decorative pavement.

The location and placement of linear pavement markings shall conform to the MUTCD. Pavement marking dimensions for legends and symbols (turn around, bike, etc.) shall conform to the Nevada Department of Transportation “Standard Plans for Road and Bridge Construction.” Mid-block pedestrian crosswalks and longitudinal striping shall be painted per the MUTCD.

All longitudinal pavement striping shall consist of traffic-rated paint as specified in Section 214 of the Standard Specifications for Public Works Construction or an approved equivalent. All striping materials are to be installed per the manufacturer’s instructions. On existing streets where the pavement surface is not in good condition, painted pavement markings may be approved by the County Engineer.

All existing or temporary pavement markings or striping shall be removed in accordance with Section 324.04 of the Standard Specifications for Public Works Construction. Excess damage during removal may require slurry seal or chip seal at the discretion of the County Engineer. Remove existing markings so that at least 95% of the underlying pavement is visible. Blacking out, or otherwise covering existing markings shall not be permitted.

3.9.18 Roadway Shoulders

Shoulders shall be constructed on all roads that do not have curb and gutter. Minimum shoulder widths shall be 4 feet. Bituminous and concrete shoulders shall have a cross-slope of two to four percent, gravel shoulders shall have a cross slope of four percent and shall drain away from the traveled way. Unpaved shoulders shall have a minimum of six-inches (6”) of Type 2, Class B aggregate base in accordance with the “Standard Specifications for Public Works Construction.” Paved shoulders shall have the same structural section as the roadway.

Table 3.6. Example Format for Regulatory Traffic Control Device Listing.

Resolution Number	Approval Date	Sign Located On:	At Intersection of:	Sign Type/Description	MUTCD Sign Code	Sign Faces	Side of Road	Direction from Int. to Sign	Distance from Intersection to Sign	Maintenance Responsibility	Area
96R-052	8/1/96	Horseman Ln	Pinto Cir	Stop	R1-1	N	W	N	0 feet	Douglas County	Ruhenstroth
96R-052	8/1/96	Antares Ave	Elges Ave	Speed Limit 15 mph	R2-1	E	N	W	50 feet	Gardnerville	Gardnerville
96R-052	8/1/96	Antares Ave	Elges Ave	Stop	R1-1	W	S	W	20 feet	Gardnerville	Gardnerville
96R-052	8/1/96	Antares Ave	Toiyabe Ave	Stop	R1-1	N	W	N	10 feet	Gardnerville	Gardnerville
96R-052	8/1/96	Apollo Ave	Elges Ave	Stop	R1-1	W	S	W	20 feet	Gardnerville	Gardnerville
96R-052	8/1/96	Apollo Ave	Toiyabe Ave	Stop	R1-1	N	W	N	10 feet	Gardnerville	Gardnerville
96R-052	8/1/96	Apollo Ave	Toiyabe Ave	Stop	R1-1	S	E	S	10 feet	Gardnerville	Gardnerville
96R-052	8/1/96	Apollo Ave	Elges Ave	Speed Limit 15 mph	R2-1	E	N	W	50 feet	Gardnerville	Gardnerville
96R-052	8/1/96	Baltic Ave	Service Dr	Stop	R1-1	SW	E	SW	0 feet	Gardnerville	Gardnerville
96R-052	8/1/96	Baltic Ave	Service Dr	Stop	R1-1	SW	E	SW	0 feet	Gardnerville	Gardnerville
96R-052	8/1/96	Bell St	Gardner St	Stop	R1-1	SW	S	SW	0 feet	Gardnerville	Gardnerville
96R-052	8/1/96	Bell St	US Highway 395	Stop	R1-1	NE	N	NE	0 feet	Gardnerville	Gardnerville
96R-052	8/1/96	Bell St	Gardner St	Stop	R1-1	SW	S	SW	0 feet	Gardnerville	Gardnerville
96R-052	8/1/96	Bell St	US Highway 395	Stop	R1-1	NE	N	NE	0 feet	Gardnerville	Gardnerville
96R-052	8/1/96	Cemetery Ln	US Highway 395	Stop	R1-1	W	S	W	0 feet	Gardnerville	Gardnerville
96R-052	8/1/96	Cemetery Ln	Spruce St	Stop	R1-1	E	N	E	0 feet	Gardnerville	Gardnerville
96R-052	8/1/96	Cemetery Ln	Spruce St	Stop	R1-1	W	S	W	0 feet	Gardnerville	Gardnerville
96R-052	8/1/96	Cemetery Ln	US Highway 395	Stop	R1-1	W	S	W	0 feet	Gardnerville	Gardnerville
96R-052	8/1/96	Cemetery Ln	Spruce St	Stop	R1-1	E	N	E	0 feet	Gardnerville	Gardnerville
96R-052	8/1/96	Cemetery Ln	Spruce St	Stop	R1-1	W	S	W	0 feet	Gardnerville	Gardnerville
96R-052	8/1/96	Cemetery Ln	US 395	Stop	R1-1	SW	E	SW	0 feet	Gardnerville	Gardnerville

3.9.19 Roadside Hazards

Non-breakaway roadside hazards shall not be located within the roadside clear zone area. Objects considered non-breakaway roadside hazards are those that do not yield or separate upon vehicular impact. The clear zone area is defined as follows:

1. Streets with vertical barrier curb of at least 6 inches in height shall not have objects located closer than 2 feet to the face of curb.
2. Streets without at least 6 inches of vertical barrier curb and with posted speeds of 35 mph or less shall not have objects of non-breakaway nature located closer than 10 feet to the edge of the traveled way.
3. Streets without at least 6 inches of vertical barrier curb, and with posted speeds greater than 35 mph shall have their clear zone areas determined by the design engineer.

3.10 Sidewalks, Curb and Gutter, Driveway Approaches, Curb-Cuts, Alleys and Bikeways

3.10.1 General

Public sidewalks, curbs and gutters shall be constructed or existing improvements replaced when deteriorated or displaced, including paving between street cut and gutter line on all streets, except sidewalks may only be omitted where the sidewalk has been waived in accordance with the Douglas County Development Code. In no instance, shall sidewalks be less than 5 feet in width (not including top of curb). In areas where handrails encroach upon the sidewalk, the sidewalk shall be widened to provide a minimum 5 foot clear width.

All concrete shall conform to the requirements for freeze-thaw environments in accordance with the “Standard Specifications for Public Works Construction.”

3.10.2 Driveway Access (Revised 10/18/2018 2018R-056)

3.10.2.1 Residential Driveways (Revised 10/18/2018 2018R-056)

Design and construction for driveway, approaches and curb-cuts shall be in accordance with County standards. At least one driveway per abutting street will be allowed to all residential parcels. One additional driveway may be allowed for a site with continuous frontage of 150 feet or more. A third driveway may be permitted if the parcel exceeds 300 feet of frontage. Driveway grades shall not exceed 14 percent. Driveway alignment must be safe and convenient to back a car out, or an adequate turn-around shall be provided. All residential driveways shall be separated by a 5 foot minimum distance to the property line. Residential driveway aprons in the urban service area as shown in the Douglas County Master Plan shall have a minimum width of 12 feet and a maximum width of 27 feet. Driveway apron width shall be measured as shown on the driveway apron details in Appendix A. Driveway aprons shall be constructed of Portland cement concrete or pavers in urban areas, and Portland cement concrete, pavers or asphalt concrete in rural areas (See Section 3.13.8 also). The residential driveway shall be no closer to the curb return than two times its width plus 5 feet.

3.10.2.2 Non-Residential Driveways (Revised 10/18/2018 2018R-056)

On Local and Collector Roadways all non-residential parcels will be allowed one driveway per abutting street. One additional driveway will be granted for a site with continuous frontages of 300 feet or more.

An additional driveway may be granted for a site with continuous frontages of 600 feet or more. For Non-residential driveways located on minor arterial roadways the minimum driveway spacing shall be 600 feet. All principal arterial roadways within Douglas County fall under the review of the Nevada Department of Transportation (NDOT) and will be subject to NDOT standards.

For non-residential parcels created after the revision to this standard, if more than one driveway is desired and the parcel does not have 300-feet of frontage a “shared private access easement” shall be provided along the property line which will access two parcels.

Non-residential driveways shall have a minimum width of 15 feet for one-way traffic and 30 feet for two-way traffic and a maximum width of 34 feet for light commercial traffic and 54 feet for heavy commercial and industrial traffic. Non-residential driveways shall be constructed of Portland cement concrete. Non-residential driveways in the Town of Minden or the Town of Gardnerville may be concrete pavers or stamped concrete as approved by the Town.

Non-Residential Driveway spacing from roundabouts, intersections, or traffic signals shall be in accordance with the NDOT Access Management System and Standards.

3.10.3 Pedestrian Ramps

Curb returns shall be constructed with "Pedestrian Ramps for the Disabled" in accordance with County, Americans with Disabilities Act Accessibility Guidelines, and Public Right of Way and Accessibility Guideline standards. A minimum of one mid-block ramp shall be provided at 'T'-intersections. Alignment of ramps and crosswalks shall provide for minimum pedestrian exposure to traffic during crossing of streets. One mid-block ramp shall be installed across the street from another at all “knuckle” intersections.

3. 10.4 Curb and Gutters

Curbs and gutters shall be 6 inch vertical (L-curb) and shall be constructed of Portland Cement Concrete in accordance with the Standard Details.

3. 10.5 Chamfered Edge at Street Intersections

At each right angle street intersection, the right-of-way line and/or road easement line at each block corner shall be a chamfered edge that is a minimum of 2 feet behind any public improvements.

Where streets intersect at angles of less than right angles or where other peculiar conditions of intersection occur, the County may require a different chamfered edge dimension.

3. 10.6 Curb Returns

Curb returns shall have minimum back of curb radii of 25 feet on urban local streets (35 feet on rural local streets), 35 feet on urban minor and major collector streets (35 feet on rural collector streets), 35 feet on minor arterial streets, and 45 feet on principal arterial streets. Curb returns shall be used at commercial driveways. Curb returns will not be allowed at residential driveways. It is the design engineer’s responsibility to ensure that appropriate radii is provided to allow maneuverability for the anticipated vehicles in the area.

3. 10.7 Bicycle Lanes and Bicycle Routes

The design of bicycle lanes, bicycle routes, and bicycle paths shall conform to the AASHTO “Guide for Development of Bicycle Facilities,” County ordinance, “Standard Specifications for Public Works Construction,” and this section. Bicycle lanes and bicycle routes shall be constructed at locations designated in the Douglas County Comprehensive Trail Plan, and shall include bicycle lane or bicycle route signs in accordance with the MUTCD.

The minimum width for bicycle lanes shall be 5 feet as measured from the edge of pavement or face of curb. If the longitudinal joint between the gutter lip and the roadway surface is within 5 feet of the curb face, a minimum of 4 feet shall be provided between the longitudinal joint and the motor vehicle lanes.

3. 10.8 Bicycle and Pedestrian Paths

The design of bicycle and pedestrian paths shall conform to the AASHTO “Guide for Development of Bicycle Facilities,” County ordinance, “Standard Specifications for Public Works Construction,” and this section. Bicycle and pedestrian paths shall be constructed at locations designated in the Master Plan.

The minimum width for two-directional bicycle and pedestrian paths shall be 10 feet. All bicycle and pedestrian paths shall be designed as two-directional facilities. Refer to the Pedestrian Path/Bikeway Class I detail in this manual for further specifications.

3. 10.9 Obstructions

No obstruction, such as power poles, street lights, signal poles and controls, sign posts, water meter boxes, pull boxes, mail boxes, etc., shall be located within public sidewalks or pedestrian paths. Necessary additional right-of-way that may be required for locating such facilities at the back of sidewalks shall be dedicated, or easements provided to the County or utility purveyor by the developer.

Where obstructions exist in areas of proposed improvements, the developer shall relocate existing obstructions out of sidewalk and pedestrian areas, and other areas of improvements. Obstructions shall not be located at intersections or other locations that interfere with sight distance.

3. 10.10 Cut and Fill Slopes

Cut and fill slopes shall be set back a minimum of 2 feet from the back of the sidewalk. If no sidewalk exists the setback shall be a minimum of 6 feet from back of curb. Back of curb drainage shall be installed as necessary. If slopes extend outside the right-of-way, slope easements shall extend at least two feet beyond where the natural surface of the ground must be excavated or covered with fill dirt or materials in constructing cuts, fills, curb and gutter, sidewalk, and drainage improvements. Design of cut and fills slopes shall also comply with the International Building Code.

3. 10.11 Alleys

Alleys required to serve a development shall be improved and conform to County standards. Alleys shall have a minimum right-of-way width of 24 feet, minimum pavement width of 20 feet, and comply with County drainage requirements. Alleys with an inverted crown shall have a 4 foot minimum concrete valley gutter down the middle to convey runoff. No on-street parking on alleys is allowed. Longitudinal grades shall conform to standards for streets, with a cross slope of 2.0% minimum from the property line toward the center of the alley, or with a cross slope of 2.0% minimum from one side of the alley to concrete curb and gutter on the low side of the alley.

3.11 Traffic and Impact Study Requirements

3.11.1 General

Traffic engineering and impact studies are required for the purpose of analyzing the impacts of development or improvement on the existing transportation system. The transportation system is composed of primarily surfaced streets, but also includes elements such as pedestrian paths, bike paths and lanes, bus routes, highways or other means of transportation. Traffic engineering studies shall be prepared and submitted to the County to identify and mitigate traffic impacts of development activity. All

traffic studies for proposed development on now vacant land shall be prepared based on Douglas County Master Plan land uses and densities. For projects within the Tahoe Basin, an approved TRPA Traffic & Transportation Analysis shall be accepted in lieu of a Douglas County Traffic and Impact Study.

Traffic engineering studies shall be presented in written format, accompanied by appropriate drawings, plans, or maps needed to clearly present the material. The study shall clearly list all assumptions and criteria upon which the analysis is based. All references shall be listed by author, publications, name and date. Traffic engineering studies are required if one or more of the following conditions are met:

1. The proposed development will generate 80 or more peak hour trips (the sum of all exiting trips plus all entering trips) as determined using the Institute of Traffic Engineers (ITE) trip generation rates or other such sources accepted by the Engineering Division.
2. The proposed development will generate 500 or more trips per day.
3. The proposed development contains phasing, and impacts from the cumulative phasing have net effects of items 1 or 2. In this case, a traffic study shall be required with the first phase of the development.
4. The Engineering Division determines that a traffic study is required. For example, a Traffic Engineering Study may be required for small developments that do not satisfy one of the above requirements if they are near a school, community shopping or recreation area, near a historic area, or will generate truck traffic. On small developments, the Engineering Division may require an analysis of the proposed access, safety issues, and the internal street system or parking.
5. The proposed development contributes to the need for traffic and/or signal improvements.

3.11.2 Scope of Work and Method

The Engineering Division will approve the scope of work and method of analysis prior to the start of any traffic engineering study. For all projects located within the Town of Minden, Town of Gardnerville, or a GID, a scoping meeting with the County Engineering Division and respective Town or GID shall be conducted prior to the start of any traffic engineering study. All traffic engineering studies shall be prepared by, or under the direct supervision of, a professional engineer licensed in **Nevada with adequate experience in transportation or traffic engineering**. The study area shall include all portions of the transportation network that the Engineering Division or the traffic engineer believes may be affected by the project. The analysis shall include all segments and intersections of the surrounding transportation system.

3.11.3 Preliminary Site Plan Review

A preliminary project site plan indicating land uses, with a level of detail equivalent to a zoning map shall be submitted to the Engineering Division for review as part of the design review application. The preliminary project site plan will be used to establish the limits of the study, the streets and intersections to be analyzed and other study criteria.

3.11.4 Traffic Engineering Study Requirements

In reviewing the scope of work proposed by the consultant for the traffic engineering study, the criteria in the following sections will be considered by the County.

3.11.4.1 Previous Traffic Studies

Applications shall include copies of all previously approved studies applicable to the project or referenced in the new study. If a previously approved traffic engineering study exists for a portion of the study limits, then an analysis of the differences in results shall be included as part of the scope of the current traffic engineering study. Simply referencing previous studies shall not be sufficient.

3.11.4.2 Master Plan, Zoning and/or Tentative Map Applications

The traffic engineering study shall be based on the Douglas County Master Plan designations, zoning and/or tentative map configurations, at the maximum allowable densities and uses.

3.11.4.3 Scope of Traffic Engineering Study

A sample table of contents for a traffic engineering study report is shown in Table 3.7. The traffic engineering study shall include the following items as a minimum:

1. Project Description
 - a. Include site plans and location maps
 - b. Describe and quantify the existing and proposed land uses and zoning, development intensities, and uses of the project site as follows:
 - (1) Existing Conditions: The Traffic Engineering Study shall generate traffic volumes based on the current traffic counts. This will be the basis for further comparison of the proposed project impacts on the existing transportation system.
 - (2) Existing Conditions Plus Project: The traffic engineering study shall generate traffic volumes based on the current traffic counts plus the proposed project land uses. This will indicate the amount to which the project will impact the existing transportation system.
 - (3) Master Plan Build-Out Plus Project: Using current traffic counts either conducted specifically for this study, or as approved by the Engineering Division as a base count, the traffic engineering study shall generate traffic volumes based on land uses and densities at full build-out of the Douglas County Master Plan for the existing street and transportation configurations and approved projects in the study area. This will indicate the amount to which this project and all other proposed future projects will cumulatively impact the existing transportation system.
 - c. Discuss the project phasing and timing of proposed and anticipated future development.
 - d. Submit site plans which shall include the location, separation distance, and number of proposed driveways and intersections. Include all existing and proposed collector, arterial, and expressway facilities through and in the vicinity of the project.
 - e. Describe the relationship of all access points to the transportation network including separation distance. The descriptions shall include existing driveways and intersections within 300 feet from the project site, and all intersections within the project site.
 - f. Describe bicycle and pedestrian facilities.

- g. Discuss existing and proposed public transit service and bus stop improvements.
 - h. Describe all other features that affect traffic flow including crosswalks, school bus stops, and postal cluster boxes.
 - i. Describe schools route plans and school route maps.
2. Trip Generation:
- a. Trip generation for average daily trips (ADT), A.M. peak hour trips (including in and out traffic split), and P.M. peak hour trips (including in and out traffic split) shall be based on type and intensity of land use.
 - b. Trip generation shall be based on data published in “Trip Generation,” by the ITE. If published data or local trip generation studies are not available, the engineering firm shall obtain approval from the Engineering Division for estimated trip rates.
 - c. Indicate how peak periods were identified.
 - d. Provide traffic counts for a typical day; include dates, times, and weather conditions. Traffic counts shall not be more than twelve (12) months old.
 - e. Provide traffic volume maps for all roads and intersections.
3. Trip Distribution and Assignment
- a. Describe trip distribution for A.M. and P.M. peak periods, noon hour, and existing and future scenarios evaluated in the traffic study.
 - b. Describe the methods used to distribute and assign trips.
 - c. Trip distributions and splits shall be approved by the Engineering Division.
4. Impact Analysis
- a. Prepare an impact analysis including effects to Level of Service (LOS) for the affected roads and intersections for the following time periods for the A.M. and P.M. peak hours:
 - (1) Existing conditions without project
 - (2) Existing conditions plus project (at project build-out)
 - (3) Douglas County Master Plan Build-out plus project (assume build-out in 20-years.)
 - b. For affected intersections, the “critical movement” method of analysis shall be used. An example of this analysis is provided in Figure 5-8 of the “Traffic Engineering Handbook.”
 - c. Pedestrian movements shall be considered in the analysis.
 - d. Roadway operational characteristics and analysis techniques shall be based on the MUTCD by the Federal Highway Administration, “Guidelines for the Design of Streets and Highways” by AASHTO, and the “Highway Capacity Manual” by the Transportation Research Board.
 - e. Analyze the adequacy of storage space for turning vehicles considering signal phasing, signal length, and traffic volumes.
 - f. Analyze the adequacy of street intersection spacing.

- g. Analyze the adequacy of site driveways and internal circulation. Driveway design shall be based on the type of traffic that will use the driveway and adjacent street. Service vehicle access shall be reviewed and based on the size and operating characteristics of service vehicles, particularly turning radii.
 - h. Safety and neighborhood impacts shall be analyzed. Obtain and review traffic accident data for the study area.
 - i. Analyze parking and pertinent site distances.
 - j. Analyze the effect of the project on existing road structures when required by Douglas County. Analysis shall include:
 - (1) Both the site-generated traffic and the construction traffic associated with the project
 - (2) An estimate of the total number of equivalent single axle loads (ESALs) generated by the project at completion of the project (including construction traffic), at five years following initiation of construction, and 20 years after completion of the project.
 - (3) An estimate for each affected road, of the remaining life (in both ESALs and years) of the road both with (including construction traffic) and without the project. Non-destructive testing, such as Falling-Weight Deflectometer testing, may be required for this analysis. Douglas County will, upon request, provide available information (if any) for this analysis. The traffic report may require a geotechnical engineering supplement to address traffic impacts.
 - k. Analyze existing school route plans and school route maps; prepare school route plans and school route maps in accordance with the MUTCD.
5. Impacts and Mitigation:
- a. A traffic LOS C or better, in the context of providing a safe, efficient and convenient transportation system, shall be maintained through mitigation of impacts from all conditions on all County, Town, and District maintained arterial, and collector roads and at County road intersections. The Engineering Traffic Study shall include recommendations for mitigation of project traffic impacts, including timing of improvements, and schematic drawings for recommended mitigation.
 - b. If the project impacts an intersection where a traffic signal is anticipated to be needed during the next 10 years, the developer shall pay its pro-rata share of the cost of the traffic signal. The pro-rata share shall be determined as the percent of the critical movement capacity of the signalized intersection utilized by the project, times the total estimated cost of the traffic signal. The percent of capacity shall be determined as follows:
$$\% \text{ of the Critical Movement Capacity} = \frac{\text{Project-Generated Critical Movements}}{\text{Existing Background Critical Movements}} \times (100\%)$$

The total estimated cost of the traffic signal shall include, but not be limited to, the itemized costs for complete engineering design (soils data, additional traffic studies, etc.), permitting, right-of-way acquisition, preparation of bidding documents, construction of the signal and related improvements (paving, striping, signage, etc.), construction administration, testing, inspection, contingencies, and

- any other costs which are needed to deliver complete improvements. The developer shall submit a cost estimate, prepared by a professional engineer licensed in Nevada, for approval by Douglas County. If the County has in its possession a current detailed estimate of costs which is acceptable, an estimate submitted by the developer may not be required.
- c. The engineer shall determine the feasibility of constructing the mitigation measures. The feasibility analysis is not to be determined from the standpoint of the single project. In the case of existing or master-planned roads through or adjoining the project, recommended mitigation measures shall include dedication of right-of-way and construction of improvements identified in the transportation element of the Douglas County Master Plan, and adopted 5-Year Transportation Plan.
6. Results:
- a. Traffic studies shall include executive summaries at the beginning of the report, and technical appendices at the end of the report.
 - b. The Engineering Traffic Study shall further contain the following information:
 - (1) Basic Discussion: The traffic engineering study shall be prepared so that minimal reference to other sources of information is required to understand the study results. Tables and figures shall be used where necessary to clearly list and itemize numbers and details of the study assumptions and results.
 - (2) Existing Streets and Intersections: The impacts on the existing transportation system, without the proposed improvements shall be clearly explained. This will be the basis for comparison of the developed conditions. It will also provide a check against other sources of information such as the transportation element of the Douglas County Master Plan. Provide recommendations, based on this analysis, of the required improvements needed to meet the Douglas County Master Plan and LOS requirements for traffic capacity at all conditions.
 - (3) New Streets and Intersections: The traffic engineering study shall clearly justify the proposed transportation system improvements and show how they meet the Douglas County Master Plan criteria and policies. Additional improvements required meeting the Douglas County Master Plan criteria and policies, not indicated in the original project assumptions and proposal shall be clearly detailed. The financial responsibility for all proposed improvements shall also be clearly detailed. Compare the results of this analysis with the proposed Douglas County Master Plan build-out improvements. Where cost sharing is anticipated, all contributing parties shall be identified and a pro-rata share, both in percentage and dollar amount, shall be provided.

Table 3.7. Sample Table of Contents for
Site Traffic Access and Impact Study Report.

- I. Introduction and Summary
 - A. Purpose of Report and Study Objectives
 - B. Executive Summary
 - 1. Site Location and Study Area
 - 2. Development Description
 - 3. Principal Findings
 - 4. Conclusions
 - 5. Recommendations (Specific mitigation measures and/or contributions)
- II. Proposed Development (Site and Nearby)
 - A. Summary of Development
 - 1. Land Use and Intensity
 - 2. Location
 - 3. Site Plan
 - 4. Zoning
 - 5. Phasing and Timing
- III. Area Conditions
 - A. Study Area
 - 1. Areas of Influence
 - 2. Areas of Significant Impact (may also be part of Chapter IV)
 - B. Study Area and Land Use
 - 1. Existing Land Uses
 - 2. Existing Zoning
 - 3. Anticipated Future Development
 - C. Site Accessibility
 - 1. Area Road System
 - a. Existing
 - b. Future
 - 2. Traffic Volumes and Conditions
 - 3. Transit Service
 - 4. Existing Relevant Transportation System Management Programs
 - 5. Other as Applicable

Table 3.7 (Continued)

- D. Condition of Existing Roads
 - 1. Structural Section
 - 2. Remaining Pavement Life
- IV. Projected Traffic
 - A. Site Traffic (each horizon year)
 - 1. Trip Generation
 - 2. Modal Split
 - 3. Trip Assignment
 - B. Through Traffic (each horizon year)
 - 1. Method of Projection
 - 2. Non-site Traffic for In Study Area
 - a. Method of Projections
 - b. Trip Generation
 - c. Modal Split
 - e. Trip Assignment
 - 3. Through Traffic
 - 4. Estimated Volumes
 - C. Total Traffic (each horizon year)
- V. Traffic Analysis
 - A. Site Access
 - B. Capacity and Level of Service
 - C. Traffic Safety
 - D. Traffic Signals (critical movement analysis and developer prorata share)
 - E. Site Circulation and Parking
- VI. Improvement Analysis
 - A. Improvement to Accommodate Base Traffic
 - B. Additional Operational Improvements to Accommodate Site Traffic
 - C. Improvements Needed to Mitigate Road Structural Damage from the Project
 - 1. Damage due to construction traffic
 - 2. Damage due to project -generated traffic
 - D. Alternative Improvements
 - E. Status of Improvements Already Funded, Programmed, or Planned
 - F. Evaluation

Table 3.7 (Continued)

- VII. Findings
 - A. Site Accessibility
 - B. Traffic Impacts
 - 1. Level of Service on Roads and Intersections
 - 2. Damage to Road Structural Section
 - C. Need for Traffic/Roadway Improvements
 - 1. Operational Improvements (left turn lanes, through lanes, access, etc.)
 - 2. Mitigation of Roadway Structural Damage
 - 3. Traffic Signals and Developer Pro-rata Share
 - D. Compliance with Applicable Local Codes
- VIII. Recommendations
 - A. Site Access/Circulation Plan
 - B. Roadway Improvements
 - 1. On-Site
 - 2. Off-Site (traffic signal contributions, mitigation of structural damage, operational improvements, etc.)
 - 3. Phasing (if appropriate)
 - C. Transportation System Management Actions
 - 1. Off-Site
 - 2. On-Site Operational
 - 3. On-Site
 - D. Other
- IX. Conclusions

3.12 References

1. American Association of State and Highway Transportation Officials, "AASHTO Guide for Design of Pavement Structures," Washington, D.C.
2. Americans with Disabilities Act, Public Law 101-336.
3. "Guidelines for Urban Major Street Design," Institute of Transportation Engineers, Washington, D.C.
4. "Guide for Development of Bicycle Facilities," American Association of State Highway and Transportation Officials, Washington, D.C.
5. "Guide for the Design of Pavement Structures," American Association of State Highway and Transportation Officials, Washington, D.C.
6. "Highway Capacity Manual, Special Report No. 209," Transportation Research Board, Washington, D.C.
7. "Manual of Traffic Signal Design," Institute of Traffic Engineers, Washington, D.C.
8. "Manual on Uniform Traffic Control Devices," Federal Highway Administration National Advisory Committee on Uniform Traffic Control Devices, Washington, D.C., U.S. Government Printing Office.
9. Nevada Department of Transportation, "Access Management System and Standards," Carson City, Nevada.
10. Nevada Department of Transportation, "Pavement Structural Design and Policy Manual," Carson City, Nevada.
11. Pinsof, Susan Anderson and Terri Musser, "Bicycle Facility Planning," Planning Advisory Service Report Number 459, American Planning Association, October 1995.
12. "A Policy on Geometric Designs of Highways and Streets," American Association of State Highway and Transportation Officials, Washington, D.C.
13. "Roadside Design Guide," American Association of State Highway and Transportation Officials, Washington, D.C.
14. "Traffic Engineering Handbook," Institute of Traffic Engineers, Washington, D.C.
15. "Trip Generation," Institute of Traffic Engineers, Washington, D.C.



Division 4 Water Systems

DIVISION 4 WATER SYSTEMS

4.1 Design Criteria

The following design criteria shall govern the design of water distribution and transmission facilities. The intent of these criteria is to promote water system designs that will provide safe, adequate, and dependable water service without excessive maintenance costs. All water systems shall comply with the requirements of this manual, American Water Works Association standards, the “Recommended Standards for Water Works,” Appendix E Backflow Control and Appendix F Water Facilities from Title 20, and NAC 445A.

Improvement plans for water systems and facilities must be reviewed and approved by the Nevada Division of Environmental Protection (NDEP) Bureau of Safe Drinking Water (BSDW), the Engineering Division **and** the local entity which will accept and maintain the improvements. Private water systems providing service to 25 or more residents must also receive approval from the Public Utilities Commission. Refer to Division 2 Improvement Plans for water system improvement plan requirements.

4.1.1 Water Supply Pressure

Minimum residual pressure in the distribution system shall be 20 psi at ground level for all service connections during all conditions of fire flow experienced during maximum day demand, 30 psi during peak hour demand, and 40 psi during maximum day demand. Static pressures shall not exceed 100 psi. Normally the use of booster pumps to increase pressures in localized areas will not be allowed. Review of the use of booster pumps in localized areas will include, but not be limited to, analysis of the 20-year life cycle costs (including operation and maintenance costs).

4.1.2 Water Demand Rates

For design of water systems, system capacity shall be based on Table 4.1.

Table 4.1
Source Water and Treatment Production Capacity per Residential Equivalent.

Service Area Demand (Residential Equivalents)	Metered System (gpm)	Unmetered System (gpm)
0 - 100	2.0	2.5
101 - 250	1.5	2.0
251 - 500	1.2	1.7
501+	1.0	1.5

4.1.3 Required Fire Flow

Fire flow shall be as required by the fire authority having jurisdiction. Minimum fire flow shall be 1,500 gpm within the Lake Tahoe Basin, and 1,000 gpm elsewhere, for a 2-hour duration with a minimum residual pressure of 20 psi at any point in the distribution system. Calculations to determine the residual pressure shall assume the maximum day demand is occurring during the fire flow. Pumps on underground wells shall not be used to provide required fire demand or fire flow.

4.1.4 Maximum Velocities

Sizing of distribution and transmission mains shall be such that water velocity meets the minimum requirements of NAC 445A.

4.2 Preliminary Engineering Report

The developer or their engineering consultant shall prepare and submit a Preliminary Engineering Report (PER), in accordance with Rural Utility Service (RUS) Bulletin 1780-02 (refer to Douglas County Public Works website for RUS Bulletin), to the County for all County-owned water systems. This report shall consider population, environmental, operation, maintenance, and financial impacts of the proposed improvements. The County maintains a water model which shall be updated with the developers proposed project as part of the PER.

The developer's engineering consultant is responsible to provide a complete list of proposed distribution/transmission lines, pumping facilities, storage tanks, and system appurtenances to serve the proposed project. The proposed improvements shall be incorporated into the existing system model and the following information/scenarios shall be evaluated:

1. Extended period simulation during Average Day Demand
2. Extended period simulation during Maximum Day Demand
3. Steady state simulation during peak hour demand
4. Fire flow simulation at Maximum Day Demand for the worst case scenario in the most critical areas of the system
5. Extended period and fire flow simulations for the proposed project
6. Water quality and water age analysis on a case-by-case basis

Douglas County shall update the model with the additional information. The developer shall be charged for the water modeling services as established by County resolution. Work completed by the developer's consultant can be submitted to the County for incorporation into the model which may reduce costs for water modeling services. The County shall produce a modeling report that outlines the methods and assumption used to develop the model, including, but not limited to:

1. Source and accuracy of elevation data
2. Scaling methods
3. Demand distribution
4. Fire requirements, including documentation from the applicable fire authority
5. Pump curves
6. Proposed control logic
7. A tabulation of water system pressures for all simulations
8. Compliance with NAC 445A
9. Other, as required or requested

Douglas County will produce a model approval letter or summary of required changes or modifications to the proposed improvements to bring the improvements into compliance with existing County operations/performance standards and infrastructure planning.

4.4 Water Rights

The quantity of water rights must be sufficient to meet the demand of the project. Water right dedication amounts as required by the Douglas County Development Code are minimum requirements; refer to Code Section 20.100.040. The applicant or the applicant's engineer shall confirm the water rights

required to meet the project demand through a technical analysis approved by the Public Works Department or the applicable water purveyor.

4.5 Distribution Mains Size and Material

Distribution mains shall be sized to deliver required flows at the pressures specified in Section 4.1.1 Water Supply Pressure. Minimum size for network piping (distribution and transmission mains) shall be 8 inches in diameter, unless approved otherwise by NDEP and/or water purveyor. All mains shall be looped and networked, with the exception of mains that serve cul-de-sacs, to provide alternate flow routes

Distribution main pipe shall be either ductile iron pipe (DIP) or polyvinyl chloride (PVC). DIP shall be designed in accordance with AWWA C150 and shall be manufactured in accordance with AWWA C151. DIP shall be cement mortar lined and seal coated in accordance with C104. The distribution main may be PVC in conformance with AWWA C900 Standard for PVC Pressure Pipe, 4 Inches through 12 Inches or AWWA C905 for PVC Pressure Pipe, 14 Inches through 48 Inches. If ductile iron pipe is used, a soil analysis and corrosion study shall be submitted with the water system improvement plans and provide recommendations for protection from corrosion by polyethylene encasement.

The distribution main shall be pressure rated for the maximum working pressure which includes surge pressures resulting from an instantaneous valve closure. Minimum ratings for the pipe shall be Pressure Class 350 for DI pipe less than 16 inches in diameter and Class 250 for DI pipe 16 inches and greater, and Class 235 DR 18 for PVC pipe. Ductile iron pipe and fittings shall be protected from corrosion by polyethylene encasement in conformance with ANSI/AWWA C 105/ A.21.5-05 American National Standard for Polyethylene Encasement for Ductile Iron Piping for Water and Other Liquids as recommended by a soil analysis and corrosion study. Seismic design shall be incorporated in all areas where the transmission main crosses a fault.

4.5.1 Distribution Main Bedding

Class A backfill used as bedding shall be in conformance with Subsection 200.03.02 of the Standard Specifications for Public Works Construction. Bedding material shall be brought up in 4 inch lifts to 12 inches above the crown of pipe. In wet trenches, cutoff walls (water stops) shall be constructed to prevent the piping of water in the bedding material. The native soil conditions shall be evaluated to determine if a filter fabric wrap of the bedding material is needed to prevent migration of native soils into the bedding material. The design of the cutoff walls (water stops) shall be submitted to the Engineering Division with the improvement plans. Each lift shall be compacted by an approved method. Typical trench sections shall be as shown in the Standard Details.

4.5.2 Main Location

All water mains shall be installed in public rights-of-way or public easements. Minimum easement widths shall be as required in Section 9.2 Easement Size. Minimum cover over a water main at all locations shall be 42 inches. Minimum cover shall be the distance from the top of the water main to finished grade. Location of water mains in public rights-of-way shall conform to the Standard Details. Designs shall minimize the use of high points by maintaining positive slopes; this may require that water mains are installed deeper than minimum cover requirements.

4.5.3 Utility Clearances

Sanitary sewers shall be located to minimize potential contamination and disturbance of water supply. Additional requirements may be imposed by the local utility companies, and the Nevada Division of Environmental Protection, Bureau of Safe Drinking Water. See NAC 445A. **Concrete or cement slurry encasement of the sewer main or water main will not be allowed in lieu of required clearances.**

4.5.4 Stream and Ditch Crossings

Crossing details of pipe, piers, anchorage, transition coupling, etc. shall be shown on the improvement drawings. Crossings shall be per NDEP Bureau of Safe Drinking Water Requirements. Ductile iron pipe with restrained joints shall be used under the full stream or ditch width, and 10 feet on each side. All stream, irrigation ditches, and ditch crossings shall have a minimum clearance of 5 feet between the stream bottom and top of pipe, and shall be enclosed in a pipe sleeve, or covered with a concrete cap. Consideration shall also be given to protecting the pipe during stream flooding and scour. A scour analysis shall be provided as required by the Engineering Division. Stream crossing and construction methods shall be approved by the appropriate agency (Nevada Division of Environmental Protection, Nevada Department of Fish and Game, Nevada State Lands, Water Conveyance Advisory Committee, and the Corps of Engineers). See NAC 445A.

4.5.5 Valves

Valves in commercial and industrial areas shall be located in such a manner that water main lengths of not more than 500 feet can be isolated by valve closures. Valves in all other areas shall be located in such a manner that water main lengths of not more than 800 feet can be isolated by valve closures, unless a shorter length is required by the reviewing agency. There shall be three valves at every tee and four valves at every cross fitting. If distances between valves will be less than 200-feet or no service laterals exist between valves this standard may be modified. Valves 12 inch and smaller shall be resilient-seated gate valves. Valves larger than 12 inch shall be butterfly valves, or as approved by water authority. Valves shall be in conformance with AWWA C509 Standard for Resilient-Seated Gate Valves, for Water and Sewerage Systems and AWWA C504 Standard for Rubber Seated Butterfly Valves. Provide and install extension stems so that the valve operating nut is not greater than 3 feet below finished grade. Valve boxes and covers shall be rated for H-20 traffic and installed in accordance with the Standard Details. Valves shall have a minimum of 24 inches of cover over the operating nut. Valve boxes shall not be installed in ditches.

4.5.6 Fire Hydrants

In all areas where fire hydrants are required along roadways, the spacing between adjacent hydrants shall be determined by the appropriate fire authority, but shall not exceed 500 feet in residential areas and 300 feet in institutional, commercial, and industrial areas. The spacing between adjacent fire hydrants in areas and locations other than along roadways shall be determined by the appropriate fire authority.

Hydrant spacing shall be measured along the shortest route within the traveled way of streets which connect the hydrants. Wherever possible, hydrants shall be located at street intersections. All other hydrants along roadways shall be located at the intersection of property lines and street right-of-way boundaries. Fire hydrants shall be installed in accordance with the Standard Details. No portion of the fire hydrant shall be located within the sidewalk or roadside ditch. Bollards shall be installed around all fire hydrants that are not protected by curb and gutter and in all commercial and industrial areas whether or not curb and gutter is present.

The hydrant lateral which interconnects the pipeline and the hydrant shall be not less than 6 inches in diameter. A maximum length of 150 feet of 6 inch lateral serving a fire hydrant from a single source shall be allowed. A larger size water main shall be required for any distance greater than 150 feet. A 6 inch gate valve shall be installed in all hydrant laterals. Water service or fire service connections are not allowed on fire hydrant laterals. The type or style and location of fire hydrants shall be determined by the County, town, fire department, or general improvement district as appropriate; however, all fire hydrants shall be freeze-proof dry barrel hydrants.

4.5.7 Services

Water services shall be located per the standard detail titled “Typical Utility Laterals Locations, .” Water service connections shall be installed at right angles to a water main and the point of connection shall not be within a street intersection. The size of the water service from the water main to the meter box shall be equal to the size of the water meter. Water service connections to private water lines **are not** allowed. All services shall be equipped to allow for installation of a water meter. Minimum residential service line size shall be ¾ inch for service to a single meter and 1 inch to double meter services.

The meter box shall be located within the public right-of-way or easement adjacent to an existing or proposed curb line. Backflow prevention devices are private facilities and shall be located out of the public utility easement or right of way. In alleys or easements, meter boxes shall be located at a point as close as practicable to the property line near which the water main is located. All meter boxes shall be located outside of driveways, driving surfaces, and other areas where access for operation and maintenance may be restricted. Whenever possible, double meter boxes shall be located on residential property lines between lots with a single service line from the water main to the meter box.

Each commercial building shall have a separate water service connection at the public water main and a separate meter. Commercial irrigation lines shall have separate connection at the public water main and a separate meter. Fire service lines shall have a connection at the public water main, separate from the domestic and irrigation connections.

Meter boxes shall be as approved by water utility. Service lines shall be polyethylene pipe or copper tubing. Water meters shall be ¾ inch (for residential services on County water systems, or the size required by the reviewing agency for other water systems). Douglas County will provide direction on the specific brand and model of water meter that will be acceptable for use. Water service connections shall be installed in accordance with the Standard Details.

4.5.8 Locating Tape

All buried, nonmetallic transmission, distribution and service pipes shall have a locating wire and a locating tape. The locating wire shall be installed and secured to the pipe, and the locating tape shall be installed on top of the pipe bedding envelope. The locating tape shall bear a continuous message “Caution - Water Line Buried Below” or words of similar nature. The ends of the locating wire shall be accessible and extend into all valve boxes or other underground vaults. The locating wire shall be a minimum 12 gauge copper-clad steel wire with HDPE coating.

4.5.9 Permits

The improvement plans shall clearly indicate that all work in rights-of-way requires a County site improvement or encroachment permit.

4.5.10 Hot Taps

Hot taps are allowed on active water mains for water main extensions. Equivalent diameter hot taps are prohibited. For equivalent size main extensions, a standard tee with valves on all legs of the tee shall be cut in. In locations where a standard tee connection would result in significant service interruption, the County Engineer may approve a hot tap. The hot tap shall be for the next smaller diameter tap available after which a reducer will be installed to increase the main size to the designed water main diameter.

4.5.11 Blowoffs (Flush Valves)

Fire hydrants shall be used as blowoffs for in-line low points and all dead ends. Temporary blowoffs shall be provided as necessary to pressure test and chlorinate the water mains. Temporary blowoffs shall be removed upon acceptance of the water line.

4.5.12 Air and Vacuum Valves and Air-Release Valves

Air and vacuum valves and air-release valves shall be installed at all high points in the water mains and where required by the Engineering Division. Air and vacuum valves and air-release valves shall be installed in accordance with the Standard Details. Air and vacuum valves and air-release valves shall be tested and approved in accordance with AWWA C512 Standard for Air-Release, Air/Vacuum, and Combination Air Valves for Water Works Service.

4.5.13 Pressure Reducing Valves

Pressure reducing valves shall be provided on distribution mains as necessary so that the system pressure will not exceed 100 psi static pressure at the lowest ground elevation of a pressure zone. Pressure reducing valves shall be installed in concrete vaults. Concrete vaults shall be rated for H-20 traffic. The vault entrance hatch shall be similar to Bilco type rated for H20 loading and constructed out of aluminum and secured to the vault structure. Entrance hatches constructed out of steel, that use torsion bars, or that are not designed to minimize water entry into the vault are not acceptable. The cover shall lock securely in the open position and shall have a locking mechanism suitable for a padlock.

The size of the concrete vault shall be adequate to allow access to the pressure reducing valve for maintenance. Pressure reducing valves are preferred to be located outside of the traveled way. Concrete vaults shall not be located within a sidewalk or driveway. The installation shall provide for minimum clearance of 24 inches from the inside walls and 18 inches to the floor of the concrete vault to valves or piping. The installation shall include bypass piping and valving, and isolation valves to allow removal of the pressure reducing valve without utilizing additional valves outside of the concrete vault.

4.5.14 Cross Connection

The term “cross-connection” shall mean any unprotected actual or potential connection, auxiliary intake, bypass, or other piping arrangement between a public water supply and any other source through which it is possible to introduce by backsiphonage and/or backpressure any used water, industrial fluid, gas, or other substance from a source which does not comply with the Primary or Secondary Drinking Water Standards. Unprotected cross-connections with the public water supply are prohibited.

An approved backflow prevention assembly shall be installed on each service line to a customer’s water system at or near the property line or immediately inside the building being served; but, in all cases, before the first branch line leading off the service line wherever the following conditions exist:

1. In the case of premises having an auxiliary water supply which is not or may not be of safe bacteriological or chemical quality and which is not acceptable as an additional

source by the County, the public water system shall be protected against backflow from the premises by installing an approved backflow prevention assembly in the service line appropriate to the degree of hazard.

2. In the case of premises on which industrial fluids or other objectionable substances are handled in such a fashion as to create an actual or potential hazard to the public water system, the public system shall be protected against backflow from the premises by installing an approved backflow prevention assembly in the service line appropriate to the degree of hazard.
3. In the case of premises having (1) internal cross-connection that cannot be permanently corrected or controlled, or (2) intricate plumbing and piping arrangements or where entry to all portions of the premises is not readily accessible for inspection purposes, making it impracticable or impossible to ascertain whether or not dangerous cross-connections exist, the public water system shall be protected against backflow from the premises by installing an approved backflow prevention assembly in the service line.

4.5.15 Backflow Prevention Devices

Each water service connection shall have an assembly for the prevention of backflow, of a type that is commensurate with the degree of hazard that exists on the property of the customer of a public water system. The type of protective assembly required under this section shall depend upon the degree of hazard that exists. The County reserves the right to install a more stringent device than listed if; in the County's sole judgment the particular circumstances require a higher degree of backflow prevention. All backflow prevention devices shall meet the requirements of NAC 445A and the American Backflow Prevention Association regulations at a minimum in addition to following requirements.

4.5.14.1 Vacuum Breakers

An atmospheric vacuum breaker or pressure vacuum breaker shall be used only for protection against pollution or contamination under conditions of backsiphonage. Vacuum breakers (AVB, PVB, or SVB) may be used for irrigation systems, including systems for irrigation of median strips.

4.5.14.2 Spill Resistant Pressure Vacuum Breaker (SVB)

A spill resistant pressure vacuum breaker is an assembly that contains an independently operating loaded air inlet valve located on the discharge side of the check valve. The following conditions must be met for SVB installations:

1. The SVB shall be installed upstream from the terminal shutoff valve.
2. The SVB must be installed not less than 12 vertical inches above the highest point of the downstream outlet, valve or piping.
3. The SVB must not be installed at a location where backpressure will occur

4.5.15 Assembly Requirements

Backflow prevention assemblies required herein shall be a make, model and size approved by the Public Works Department or applicable water purveyor. An approved backflow prevention assembly shall mean an assembly that has been manufactured in full conformance with AWWA C510 Standard for Double Check Valve Backflow-Prevention Assembly, and AWWA C511 Standard for Reduced-Pressure Principle Backflow-Prevention Assembly, and have met completely the laboratory and field performance specifications of the Foundation for Cross-Connection Control and Hydraulic Research of the University

of Southern California (USC FCCCHR), as established in: “Specifications of Backflow Prevention Assemblies - Section 10 of the current edition of the Manual of Cross-Connection Control.”

4.5.16 Testing Requirements

It shall be the responsibility of the customer at the premise where backflow prevention assemblies are installed to have certified inspections and operational tests made at the customer’s sole expense at least once per year. In those instances where the Public Works Department deems the hazard to be great enough, certified inspections may be required at more frequent intervals. These inspections and tests shall be performed by a tester certified by the American Water Works Association, California-Nevada Section. The customer shall notify the Public Works Department two (2) working days in advance when the tests are to be undertaken so that a Public Works Department representative may witness the tests.

A test report in a form acceptable to the County shall be filed with the County Public Works Department upon installation and each time a backflow prevention device is repaired, relocated, or replaced. Approval from the County must be obtained before a backflow prevention device is removed, relocated, repaired, or replaced.

4.5.17 Installation Requirements

Backflow devices shall be installed as per NAC 445A, and as shown in the standard details. The County or applicable water purveyor shall have the final authority in determining the required location of a backflow prevention device.

4.5.18 Disinfection and Testing

All water mains shall be disinfected and tested in accordance with AWWA C651 Standard for Disinfecting Water Mains. All water mains shall be pressure tested at 150 percent of the pipe pressure class or a minimum of 150 pounds per square inch, whichever is greater, in accordance with the “Standard Specifications for Public Works Construction.”

4.5.19 Length of Open Trench in Street Areas

No trench shall be left open or uncovered overnight in a developed area. In undeveloped areas, no trench shall be opened more than three hundred (300) linear feet in advance of where backfilling and surfacing have been completed. Surfacing shall mean crushed stone trench topping and may mean temporary or permanent asphalt concrete resurfacing, if required. All surfacing requirements shall conform to applicable County requirements. If the work is delayed on the whole, or part of the project, and excavations are left open for more than three (3) consecutive days, then the contractor shall backfill the excavations and temporarily repave over the excavation area, the trench shall not be opened until the contractor is ready to proceed with the work. If the contractor neglects or fails to completely refill excavations and temporarily repave over the excavation within twenty-four (24) hours after notice to do so, then the County shall be authorized to temporarily surface the excavations and the costs shall be charged to the contractor. The contractor shall at all times provide for public access by permitting traffic to pass through the construction area. All driveways are to remain passable between the hours of 4:00 p.m. and 8:00 a.m. throughout construction.

4.5.20 Dewatering

Dewatering, sufficient to maintain the groundwater level at or below the surface of the trench bottom or base of the bedding course, shall be accomplished prior to pipe laying and jointing of water pipe. The dewatering operation shall be carried out so that it does not destroy or weaken the strength of the soil

under or alongside the trench. The normal water table shall be restored to its natural level in such a manner as to not disturb the pipe and its foundation.

Water pumped from excavations shall be disposed of by the contractor in such a manner as will not cause injury to public or private property or constitute a nuisance or menace to the public. At all times, the manner employed to discharge and to dispose of water pumped from an excavation shall be subject to the approval of the County and the appropriate permitting agency (i.e. Nevada Division of Environmental Protection - Bureau of Water Pollution Control, U.S. Army Corps of Engineers, Nevada State Lands, Division of Water Resources). All surface waters shall be prevented from entering open ditches or excavations by proper grading of the ground surface in the vicinity of the excavation.

4.5.21 Pipeline Installation

All pipe (mains) shall be laid true to line and grade as shown on the approved plans. The underground installation of all distribution mains shall be in accordance with manufacturer's recommendations and the requirements of Division 4, and the "Standard Specifications for Public Works Construction."

4.5.22 Location and Alignment

All water distribution mains shall be placed within right-of-way dedicated for public streets unless the use of easements is approved by the Engineering Division. Horizontal and vertical clearances shall comply with the requirements of Section 4.5.3 Utility Clearances. The location of distribution mains in public rights of way shall conform to the Standard Details.

When distribution mains are to be installed in existing streets, factors such as curbs, gutters, drainage ditches, sidewalks, traffic conditions, pavement conditions, future street improvement plans, and existing utilities shall be considered by the design engineer when selecting the main location and alignment.

The minimum width of easements shall be twenty (20) feet. Other factors such as side slopes and structures within the easement may require additional width. If a main is installed within an easement, temporary maintenance access with a minimum width of 12 feet may be required in accordance with Section 3.10.14 Improved Maintenance Access. Permanent maintenance access in accordance with the requirements of Section 3.10.14 Improved Maintenance Access may be required by the County or water purveyor.

4.6 Water Supply Wells

4.6.1 General

This section covers the requirements for public water supply wells on Douglas County maintained systems. Because a development requires a water source of sufficient quality and quantity, the Public Works Department may require completion of the water supply wells prior to approval of a final map. The developer shall be responsible to notify the Public Works Department prior to initiating well drilling or testing activities. The purpose of this notification is to ensure that the well is constructed and tested in a manner acceptable to the County. The County Engineer shall have the final decision as to acceptability of the well for dedication to the County.

A permit issued by the State Engineer pursuant to NRS chapters 533 and 534, must be obtained prior to initiating drilling of a water supply well. All drilling must be performed by a Nevada licensed water well driller.

4.6.2 Design Criteria

Design criteria for water supply wells are presented in the sections that follow.

4.6.2.1 Location

No well shall be located within 50 feet of gravity sanitary or storm sewers. No well shall be located within 150 feet of a sewer force main, sewer lift station, septic tank, absorption field, designated septic absorption replacement field location or other source of pollution or contamination.

4.6.2.2 Well Capacity Criterion

There shall be sufficient water from all sources to meet the maximum day demand. The flow rate for this criterion shall be the amount of water that can be delivered to the system while all water sources are being pumped to the system, not the sum of the discharge capacities of the individual wells when being pumped alone. Additionally, the total water system capacity from all facilities shall be sufficient to meet the greater of the following:

1. the maximum day demand, fire flow and fire demand when all facilities of the system are functioning; or
2. the average day demand, fire flow and fire demand when the most productive well of the system is not functioning

A minimum of two producing wells shall be provided, unless the system is physically connected to another independent municipal water system, and an interlocal contract is in place for provision of water in the event of emergencies.

4.6.2.3 Water Quality

The water from the sources shall meet the Nevada State Drinking Water Regulations with respect to microbiological, physical, chemical and radiological qualities as adopted in Nevada Administrative Code, Chapter 445, Public Water Systems - Quality. Point of entry or point of use treatment devices shall not be used on public water systems. Blending of more than one source shall not be allowed as a means to comply with the water quality requirements. Each source alone shall comply with the water quality requirements.

4.6.2.4 Standards

The following standards shall be used in the logging, test pumping, abandonment, design and construction of wells:

1. State of Nevada Division of Water Resources, Regulations for Drilling Water Wells.
2. AWWA A100 Standard for Water Wells.
3. The State Engineer's permit under which the well is to be drilled.
4. NAC 445A

4.6.2.5 Casing

Casing size shall be suitable for installing a pump, a 1 inch sounding tube and a ¼ inch air line. Material shall be suitable for placement in formation encountered. Chemical and conductivity analysis of the formation and water shall be determined via a test hole and submitted to the Engineering Division as

proof of suitability. The casing material shall be approved by the Public Works Department prior to setting the casing; stainless steel casing shall be used in all waters that are deemed corrosive. The casing thickness shall conform to State of Nevada, Division of Water Resources, Regulations for Drilling Water Wells and AWWA A100.

4.6.2.6 Well Screen

Well screen may be of continuous wire wrap design, shuttered screen, louvered screen, or bar lug screen as approved by the Public Works Department; stainless steel screen shall be used in all waters that are deemed corrosive. Screen opening shall be based on gravel pack sieve analysis and formation sieve analysis. A licensed engineer shall stamp and submit sieve analysis and recommended screen opening size to the Public Works Department for approval a minimum of two (2) working days in advance of well screen installation. A hydrogeologist, approved by the Public Works Department, with demonstrated professional experience in hydrogeology, well design and well construction may also submit the sieve analysis and recommended screen opening size.

4.6.2.7 Gravel Pack

All new wells shall include a gravel pack. The minimum gravel pack thickness shall be 4-inches between the wall of the drill hole and the casing. A licensed engineer shall stamp and submit the recommended gravel source and gradation to the Public Works Department for approval a minimum of two (2) working days in advance of gravel pack installation. A hydrogeologist, approved by the Public Works Department, with demonstrated professional experience in hydrogeology, well design and well construction may also submit the recommended gravel pack and gradation.

The gravel pack shall be placed by reverse circulation method, or by a tremie pipe, raising the tremie pipe as the gravel pack is placed. All new wells shall also include a gravel fill tube.

4.6.2.8 Drilling Method and Borehole Geophysical Logs

Direct or reverse circulation drilling methods with drilling fluid (maximum Marsh viscosity 45 seconds) shall be used for well construction. All other methods shall be approved by the Public Works Department.

At a minimum, the following borehole geophysical logs shall be run on all boreholes prior to setting casing:

1. Spontaneous Potential Curve
2. Resistivity Log
3. Electric Log
4. Caliper Log

Additional logs as recommended by the engineer or hydrogeologist, or as required by the Public Works Department, shall be run.

4.6.2.9 Plumbness and Alignment

All wells shall be tested in accordance with AWWA A100. Contractor shall be subject to the requirements of AWWA A100 Section 8. The tolerance requirements shall apply from the top of the well to the bottom of the casing.

4.6.2.10 Test Pumping

All wells shall be tested for yield and drawdown prior to final pump selection. A licensed engineer shall stamp and submit test pump size and setting to the Public Works Department for approval a minimum of two (2) working days in advance of test pumping. A hydrogeologist, approved by the Public Works Department, with demonstrated professional experience in hydrogeology, well design and well construction may also submit the test pump information to the County.

4.6.2.11 Disinfection

All wells shall be disinfected in accordance with AWWA A100. Developer shall have water samples taken and analyzed by a State approved laboratory to verify disinfection. Lab test records shall be submitted to the Public Works Department as part of the well construction record report.

4.6.2.12 Grouting and Sealing

All wells shall be grouted and sealed in accordance with the referenced standards.

4.6.3 Hydrogeologic Evaluation and Improvement Drawings

A hydrogeologic evaluation shall be submitted for all wells. The evaluation shall be prepared by a licensed engineer or a hydrogeologist, approved by the Public Works Department, with demonstrated professional experience in hydrogeology, well design and well construction and shall contain, but not be limited to the following:

1. A detailed map showing well location (Such as a USGS 7-1/2 minute quadrangle map).
2. A summary of available hydrogeologic information including reports, logs of nearby wells, water quality data, and other relevant information.
3. A description of the proposed plan for exploration, testing and well construction. This shall include proposed drilling method, lithologic logging and sampling, other logs (temperature, resistivity, specific conductance, etc.), and sampling for water quality and yield.
4. A statement of anticipated water demand from the well.

Final wet stamped construction drawings, specifications, and design calculations for the well and appurtenant facilities shall also be submitted to the Public Works Department as part of improvement plans. Construction drawings and specifications shall include all appurtenant facilities such as but not limited to pumps, building, stand-by generator, and chlorination facilities.

4.6.4 Construction

All wells shall be constructed in accordance with:

1. State Engineer Requirements - Regulations for Drilling Water Wells
2. State of Nevada Bureau of Health Protection Services Requirements
3. AWWA A100 Standard for Water Wells

The Public Works Department may place additional requirements on the design and construction of the well based on site-specific conditions. Specific items which require approval of the Public Works Department prior to construction are:

1. Borehole diameter
2. Production casing diameter and material
3. Screen type, material and slot size
4. Gravel pack design
5. Drilling technique
6. Method for installing sanitary seal and gravel pack
7. Method for providing access for taking water level measurements in completed well
8. Pump chamber length and location

Geophysical logging, sieve analysis, plumbness, alignment, and other data are to be provided to the County prior to well construction for review. The County shall have 7 days to review the required data. Gravel pack design, screen slot size, and pump chamber length and location may be adjusted in the field by the engineer, hydrogeologist, or at the request of the County based on the results of geophysical logging, sieve analysis, and other data collected as part of the drilling process. Constructing the well prior to receiving County approval may result in County denial of the well, based on the County's discretion.

All well construction shall be done under the responsible oversight of a licensed engineer, or a hydrogeologist, approved by the Public Works Department, with demonstrated professional experience in hydrogeology, well design and well construction.

4.6.5 Development

Wells shall be developed by pumping, mechanical surging, backwashing or other means. Development shall continue until no increase in the specific capacity is achieved and the sand production rate is less than 5 parts per million within the first three to five minutes of the start of pumping as measured with a Rossum Sand Tester for the greatest anticipated pumping rate. The method for determining specific capacity and sand content shall be approved by the Public Works Department. The Public Works Department shall have the final determination as to when development is complete and the sand production rate is acceptable.

4.6.6 Yield and Efficiency Testing

Yield and efficiency testing shall be conducted under the direct observation (during the entire test) of an independent hydrogeologist or licensed engineer who has been approved by the Public Works Department. Efficiency testing shall include a 4-step efficiency test at pumping rates of 50%, 75%, 100%, and 125% of expected demand from the well. The duration of each step shall be a minimum of 100 minutes, followed by an equal time recovery period. Yield testing shall consist of a constant discharge pumping test at a rate equal to or greater than the expected demand from the well. Pumping duration shall be a minimum of 72 hours. If data collected during the 72 hours pumping indicate, in the opinion of the engineer, hydrogeologist or Public Works Department that a longer test is necessary, pumping shall continue until the safe long-term yield of the well can be determined to the satisfaction of the Public Works Department. For example, wells in fractured bedrock conditions may require constant rate yield tests of 10 or more days.

As part of the final improvement drawings and specifications, the hydrologist's or engineer's proposed testing plan shall be submitted to the Public Works Department for review and approval. The testing plan shall include, but not be limited to:

1. A description of the pump and driving mechanism to be used, with rated capacities.
2. A description of the method and apparatus to be used for flow rate monitoring.
3. A description of the method and apparatus to be used to measure water levels and drawdown (a 1 inch or larger diameter sounding tube will be required.)
4. A proposed time schedule for testing.
5. A plan for disposing of the water produced during the pump test.

4.6.7 Water Quality

Water samples shall be collected at the beginning and at 24-hour intervals during the yield testing (Four samples for a 72 hour test). The sample collected at the end of the test shall be analyzed to determine if the water is in conformance with Nevada State Drinking Water Regulations with respect to microbiological, physical, chemical and radiological qualities as adopted in Nevada Administrative Code, Chapter 445, Public Water Systems - Quality. Water temperature and electrical conductivity shall be monitored during the pump test.

4.6.8 Downhole Color Television Survey

After completion of the casing, sealing, and test pumping, and prior to installation of pumping equipment, a downhole color television survey shall be completed from the ground surface to the total depth of the well. The survey shall be conducted and recorded as a camera is lowered into the well. The camera shall be lowered in such a manner and speed as to allow a detailed examination of the casing interior. The recording shall be provided to the Public Works Department as part of the Well Construction Record Report.

4.6.9 Well Construction Record Report

Where groundwater wells are constructed, a licensed engineer or a hydrogeologist, as approved by the Public Works Department, with demonstrated professional experience in hydrogeology, well design and well construction shall prepare and submit two (2) bound copies of a Well Construction Record Report containing the following information to the County prior to County acceptance or approval of the improvements:

1. A surveyed map showing the location of wells constructed.
2. A summary and recommendation report detailing the capacity and expected long-term drawdown effects (20 years) of each well constructed. The report shall include all pertinent comments related to aquifer hydraulic characteristics, sand production and water quality.
3. Descriptions and diagrams detailing materials, borehole diameters, surface seal dimensions, screened intervals, depths, static water levels and other pertinent aspects of the well construction.
4. A summary describing the drilling methods, name and address of drilling contractor, name and address of hydrogeologic consultant, and well development methods.

5. A summary report detailing the pumping test program. The report shall include a description of the test equipment, method of measuring discharge rates, method of measuring sand content, and a table outlining the type and duration of pumping tests performed.
6. A report detailing the methods of analysis used and the results of analysis of test pumping data. The report shall contain a description of well efficiency at the design production rate and the aquifer parameters determined from the constant discharge pumping test.
7. A report detailing water quality. The report shall describe sampling methods, and the results of water quality and bacteriological analysis.
8. Recommended equipping of the well including the following
 - a. Pump and Motor
 - b. Pump Building Enclosure
 - c. Recommended Treatment and Treatment Equipment
 - d. Recommended power (permanent and auxiliary/standby)
 - e. Transmission Main, Pump to Waste and Necessary Land Rights
 - f. Discussion on how the facility will operate with the system
 - g. Recommendations for special building equipment such as security breach, high/low pressure, etc.
9. The submitted report shall contain appendices which shall include:
 - a. Geologist's and Well Driller's logs
 - b. Borehole Geophysical Logs
 - c. Grain size distribution analysis of selected gravel pack
 - d. General materials documentation, including casing and screen invoices, gravel invoices, cement invoices
 - e. Required permits and logs
 - f. All pumping test data, including graphs and calculations
 - g. Water quality analysis report forms
 - h. Daily hydrologist's logs
 - i. Drawing of the completed well showing all the construction features of the well
10. A recording of well casing after grouting, sealing and test pumping

4.7 Pumping Facilities

4.7.1 General

Requirements for pumping facilities are presented in this section. Pumping facilities shall be designed by an Nevada licensed engineer with specific related experience in design and construction of pumping facilities. Facility designs shall consider and make provisions for long-term operation and maintenance.

4.7.2 Well Pumps

Well pumps shall be either vertical turbine or submersible pumps. The selection of the type of pump to be used shall depend on the size of the motor, length of the pump column, and other considerations. In general, a submersible pump shall not be used when the motor is over 100 horsepower. Submersible pump facilities shall be equipped with a foot valve and pitless unit. Wells with submersible pumps may be located outside of the pumping facility building. Wells with vertical turbine pumps shall be located inside the pumping facility building. Wells equipped with vertical turbine pumps shall be equipped with a water lubricated shaft and anti-reverse ratchet. Water-lubricated pumps shall be equipped with automatic pre-lube provisions. Pumps shall be constructed in accordance with AWWA C101 Standard for Vertical Turbine Pumps-Line Shaft and Submersible Types.

The pump capacity (discharge and total dynamic head) shall be matched with actual operating conditions. The water system improvement plans shall identify the following operating conditions and performance criteria:

1. Casing Diameter
2. Depth of Well
3. Static Water Level
4. Pumping Level
5. Pump Intake Setting
6. Required Pump Discharge
7. Total Dynamic Head at Required Discharge
8. Maximum Pump Speed (Revolutions per Minute)
9. Minimum Motor Horsepower
10. Minimum Efficiency

4.7.3 Booster Pumps

Booster pumps shall be the centrifugal type. The improvement plans shall state the following operating conditions and performance criteria:

1. Required Pump Discharge
2. Total Dynamic Head at Required Discharge
3. Maximum Pump Speed
4. Minimum Motor Horsepower
5. Minimum Efficiency

Booster pumps shall be used to move water from a lower pressure zone to a higher pressure zone. Closed loop pumping shall not be allowed. Fire demand shall be provided from storage.

4.7.4 Mechanical Requirements

All pumping facilities shall have sufficient surge control to protect piping and other equipment. Pressure fluctuations shall be maintained within 15 percent of normal operating pressures during pump starting and stopping. Adequate provisions shall be made for pressure surges caused by power outages. All

pumping facilities shall be equipped with pressure relief valves. In addition, all pumps shall be equipped with reduced voltage soft starters

All County and publicly owned facilities shall be provided with 480 volt a. c., three phase power; an engineering analysis shall be provided with all requests for an exemption to three phase power.

All pumping facilities shall be equipped with provisions for pumping water to waste, including adequate drainage and easements. The facilities shall also have a discharge meter and pressure gauge. The discharge meter shall be a Siemens Mag Flow 5100W and have a 4-20 milli-amp output and indicate total flow and rate of flow. The pressure transmitter shall be a Foxboro electronic pressure transmitter with a 4-20 milli-amp output. The discharge meter and pressure gauge shall be suitable for remote reading and shall transmit by telemetry to a location designated by the Public Works Department. Control panels shall be equipped with start counters and hour meters for all pumps. Lightning protection and transient voltage surge suppression devices shall be provided on all phases of commercial power.

Pumping facilities shall include adequate flanged isolation valves and couplings to allow for maintenance and removal of valves, meters, and other equipment. All valves shall have a rising stem or position indicator.

Adequate clear space for access, maintenance and removal and replacement shall be provided around all piping and equipment. At a minimum there shall be 18 inches clear between all piping and equipment and all obstructions.

4.7.5 Chlorination

All well pumping facilities shall be equipped with hypochlorination systems including a minimum 35 gallon container of hypochlorite solution and solution feed pump with wall mounted shelf. The chlorine tank shall have a minimum capacity of 7 days. For County facilities, the feed pumps shall be diaphragm pumps with degassing heads, adjustable stroke and speed, and a minimum turndown ration of 100:1. All of the system components shall be according to the manufacturer's recommendations to insure efficient chlorination system operation. Analyzers, chart recorders, and drum trucks for hypochlorite solution drums shall be provided. Sample taps shall be provided for both treated and untreated water. A stainless steel (no plastic heads or bowls) emergency eye wash station and shower and appropriate signs shall also be provided.

The chlorination solution tank and pump shall be located in a separate room with an exhaust fan and be isolated from the rest of the pumping facility. The design of the room shall comply with the applicable requirements of the International Building Code, and the Uniform Plumbing Code.

If water quality analysis indicates that chlorination is not adequate to comply with State drinking water requirements, the developer shall evaluate and propose appropriate treatment processes.

4.7.6 Buildings

All pumps, booster pumps, mechanical equipment, chlorination facilities, control equipment, electrical equipment and telemetry equipment shall be enclosed in a building. Buildings shall be masonry block with concrete floor and foundation. The building shall be equipped with locking steel doors. Buildings and pumping stations shall be elevated to a minimum of three feet above the elevation of a flood with a 100-year frequency, or protected to such elevation.

Where pumps are located within a pump building, adequate provisions shall be made for removal and replacement of the motor, column and pump. These provisions may include locating the pump within 4 feet of the wall with a 4 foot by 4 foot (4' x 4') hatch for removal of the assembly or providing removable roof and wall sections.

Suitable ventilation shall be required. Fans shall be thermostatically controlled. Fans and louvers shall be provided with winter covers.

The building shall be provided with suitable heaters to keep the interior air temperature above 45 degrees, emergency lighting, fire extinguisher, and storage cabinets.

Floor drains shall be provided, except in the chlorine room. The building floor shall slope to the drains.

All well pumping facilities shall be fenced with a minimum 6 foot high fence which complies with the Douglas County Development Code. The site access, size and layout shall provide adequate room for maintenance of the facility, including removal of well pumps. For removal of well pumps, there shall be adequate room for the removal equipment and stem trailer.

The exterior noise level at the property line of the well site shall not exceed 65 CNE exterior. Refer to Chapter 20.690 in Title 20 if noise levels exceed 65 CNE exterior.

A design review of the building and building permit are required. A zone change to a public facility zone and a request for a parcel map waiver may also be required if the parcel is not zoned for public use. The building site shall be landscaped and provided with an irrigation system with automatic controls. The irrigation system shall have backflow prevention and shall have automatic drains to prevent freezing, and shall comply with the requirements of Section 2.2.11.3 Permanent Erosion Control Standards. Access to the building site shall be provided by temporary maintenance access in accordance with the requirements of Section 3.10.14 Improved Maintenance Access. Permanent maintenance access in accordance with the requirements of Section 3.10.14 Improved Maintenance Access may be required by the County or utility purveyor.

4.7.7 Stand-by Generator

A stand-by engine generator shall be provided with automatic starting and load transfer equipment to operate the entire pumping load during power failure unless primary power is provided by connecting to at least two independent public power sources. The generator shall be fueled by diesel or by natural gas as approved by the County and utility purveyor. The storage tank shall have a capacity to provide a 24-hour continuous run time. Generators for County facilities shall be manufactured by Cummins Power Generation. Generators shall be provided with the following:

1. Weather-protective with silencer (NEMA Type 4), sound proofed (QuietSite Level 2 enclosure with silencer), vandal-proof and lockable housing with access to all engine and generator components
2. Above ground vandal-proof double walled storage tank, and concrete pad for secondary containment
3. Engine block heater and thermostat to allow for instantaneous start-up at -30 degrees Fahrenheit
4. Shutdown safeguards, gauges and indicator lamps for over temperature, low oil pressure, overspeed and overcrank

5. Automatic battery charger installed on the hot side of the transfer switch enabling the batter to maintain its charge when idle
6. Walkway platform and safety guards for generators larger than 75 kilowatt to provide maintenance access to engine compartment
7. Power command digital display generator set control for generator set monitoring, metering, and control system which includes Level 2 Control, front panel security key, digital display, network communications module, load monitoring module and relay module
8. Cummins Power Generation OTPC Power Command Automatic Transfer Switch to monitor the primary source, signal generator set startup, automatically transfer power, and return the load to primary power source once the power utility returns and is stabilized

The generator site shall be fenced with a minimum six (6) foot high fence which complies with the Douglas County Development Code. Access shall be through a sixteen (16) foot wide double gate. The generator site shall be landscaped and provided with an irrigation system with automatic controls. The irrigation system shall have backflow prevention and shall have automatic drains to prevent freezing, and shall comply with the requirements of Section 2.2.11.3 Permanent Erosion Control Standards. Access to the generator site shall be provided by temporary maintenance access in accordance with the requirements of Section 3.10.14 Improved Maintenance Access. Permanent maintenance access in accordance with the requirements of Section 3.10.14 Improved Maintenance Access may be required by the County or utility purveyor.

4.8 Water Storage Tanks

4.8.1 General

Water storage facilities shall be provided for all water systems. Where only one phase of a subdivision is being built, the storage facilities shall be sized and initially constructed for the entire subdivision to reduce the possibility of multiple smaller tanks. A design review of the storage tank and a building permit will be required.

4.8.2 Design Criteria

Water storage facilities shall comply NAC 445A and with the following design criteria:

1. Required storage capacity for existing water systems shall be determined by an engineer on the basis of historic data, engineering judgment, and network hydraulic modeling, correlating total water system capacity with present and anticipated demands, while maintaining minimum pressures of Section 4.1.1.
2. Booster station capacity and the total storage requirement for each pressure zone within the distribution system shall meet the maximum day requirements of that particular pressure zone. Water storage may be provided in a higher pressure zone, if an appropriate pressure regulator is installed between the zones, to serve the lower pressure area, and the requirements for the higher pressure zone are not compromised.
3. Alternative pumping capacity shall not be used in lieu of satisfying storage requirements.
4. Storage tanks shall have an overflow, and the overflow shall be sized to pass the maximum possible inflow. The overflow outlet shall be screened or protected with a flap gate and shall have a minimum air gap of 18 inches. The drainage path of water being discharged from the overflow pipe shall be identified on the plans. The drainage channel

shall be able to handle maximum possible inflow without damage to the channel or adjacent structures or property. The drainage channel shall be within an easement dedicated to the County and the drainage channel shall be extended to an existing storm drainage facility or storm drain system. Infiltration trenches will not be allowed for disposal of overflow.

5. Storage tanks shall have a drain which shall be capable of completely draining the tank. The tank drain shall direct water to the overflow channel. The route of the overflow shall be reviewed to determine that the overflow route has the capacity to transmit the maximum overflow amount. The inlet of the tank shall be located as far as possible from the outlet to allow the maximum mixing of water.
6. Storage tanks shall be located on a site which is large enough to accommodate a second tank of the same size as the proposed storage tank.
7. An in tank mixing system is required if the theoretical water age exceeds 5 days based on average day demands. For chlorinated systems the in tank mixing system is to be equipped with liquid chlorine injection system and necessary appurtenances to make the injection system operational.

4.8.3 Materials

All above ground water storage tanks smaller than 500,000 gallons shall be welded steel tanks (AWWA D100). Tanks 500,000 gallons or larger shall be either welded steel (AWWA D100) or prestressed concrete (AWWA D110 Type I or III). All underground, buried, or partially buried tanks will be prestressed concrete (AWWA D110 Type I or III). Used tanks, bolted steel tanks, American Petroleum Institute (API) steel tanks, wood tanks, thermosetting fiberglass reinforced plastic tanks, and tanks with flexible membrane liners will not be allowed.

A life-cycle costs analysis (LCCA) will be completed on all tanks larger than 500,000 gallons. The LCCA shall follow the methods outlined in 10 CFR 436A and ASTM E917. The LCCA shall consider a 60 year usable life and at minimum three tank rehabilitations project over 60 years. Determination if the tank will be constructed using welded steel or concrete will be decided by the results of the LCCA. A copy of the LCCA will be provided to Douglas County for review prior to approval of the tank material.

Steel tank bottoms shall have a minimum thickness of 5/16 of an inch and shall be constructed on neutral pH environment under the tank

For all steel tanks, a corrosion specialist shall evaluate the water chemistry and provide a written report and recommendations for a cathodic protection system. If cathodic protection is recommended, the cathodic protection system shall be an automatically controlled, impressed-current system which meets the requirements of AWWA D104 Automatically Controlled, Impressed-Current Cathodic Protection for the Interior of Steel Water Tanks. A long-life anode system shall be provided.

4.8.4 Appurtenances

All water storage tanks shall have the following appurtenances:

1. Shell Manholes (30 inch diameter minimum) - 2 each (approximately 2 feet above the base of the tank), except for buried tanks
2. Overflow Structure and Pipe

3. Outside Ladder with cage
4. Inside Ladder
5. Outside Level Indicator (all County facilities except those located in the Lake Tahoe Basin)
6. Safety Devices - ladder safety cage, rest platforms, handrails or other safety devices as required
7. Ladder Locking Device - prevents unauthorized access to the outside ladder
8. Roof Openings - at least one bug proof and lockable water tight hatch at the access point for the inside ladder
9. Vents - three each, "J" type with screens, two at edge and one at center of tank. Vents shall be designed and sized to prevent external pressure from causing the tank to buckle, and prevent the entrance of rain and surface water; and exclude dust, birds, insects and other animals as much as possible. Refer to NAC 445A.6708 and AWWA D100 Section 7.5.
10. Appropriate water level sensing and telemetering equipment
11. Bolted flange gate valve to isolate tank from distribution system
12. Sample tap with insulated, locking cover
13. Intrusion alarm on roof openings, connected to telemetry system
14. If required (based on theoretical water age), in tank mixing systems.
 - a. Passive systems (using engineered inlet and outlet valving that does not require a power source such as the Tideflex system) are preferred if sufficient inlet/outlet demands are sufficient to provide mixing. A mixing analysis is required, either performed by the equipment manufacturer or design engineer, for County review and approval that demonstrates that the passive system will provide adequate mixing.
 - b. Active system (low horsepower electric motor driven system) can be used if a passive system is not capable of providing adequate mixing. A mixing analysis is required, either performed by the equipment manufacturer or design engineer, for County review and approval that demonstrates that the passive system will provide adequate mixing.

4.8.5 Painting

Proper protection shall be given to all metal surfaces by paints or other coatings. Interior painting system shall be a three coat, two component epoxy system in accordance with AWWA D102 Coating Steel Water-Storage Tanks System Designation ICS-2-W. The interior finish coat color shall be white. The exterior painting system shall be a three coat epoxy and polyurethane painting system in accordance with AWWA D102 Coating Steel Water-Storage Tanks System Designation OCS-5-C. Final outside color may be set by the Douglas County Design Review, or the Douglas County Public Works Department.

Paints or other coatings shall conform to AWWA D102 Coating Steel Water-Storage Tanks and NSF International Standard 61. All internal coatings shall be certified for contact with potable water. Testing for this certification shall be conducted in accordance with NSF International Standard 61 or by a third party certifications laboratory accredited by ANSI.

4.8.6 Site Work

A geotechnical investigation and foundation design shall be prepared for all tank sites. The tank site shall be graded to provide suitable soil stability and drainage. The tank foundation shall be placed entirely on cut when practical. There shall be access to all sides of the tank on a graveled (Type 2, Class B aggregate base) road, minimum width of 15 feet, circling the tank. The site shall be fenced with a minimum 6 foot high fence which complies with the Douglas County Development Code. Access shall be through a 16 foot wide double gate.

The tank site shall be landscaped and provided with an irrigation system with automatic controls. The irrigation system shall have backflow prevention and shall have automatic drains to prevent freezing, and shall comply with the requirements of Section 2.2.11.3 Permanent Erosion Control Standards. Access to the tank site shall be provided by temporary maintenance access in accordance with the requirements of Section 3.10.14 Improved Maintenance Access. Permanent maintenance access in accordance with the requirements of Section 3.10.14 Improved Maintenance Access may be required by the County or utility purveyor.

4.8.7 Inspection and Testing

All tanks shall be tested and inspected in accordance with AWWA D100 Standard for Welded Steel Tanks for Water Storage. A coatings inspector that is certified by NACE International shall inspect interior and exterior coatings. All field welds shall be inspected by the radiographic method by an independent testing agency. The Engineer of Record shall submit a written report, including x-ray film, in accordance with AWWA D100 Standard for Welded Steel Tanks for Water Storage to the Engineering Division.

Upon completion of all construction work and tank coatings, and in conjunction with the disinfection procedure, the tank shall be completely filled with water and allowed to sit for a period of 72 hours with no leakage. Water level measurements shall be taken at the start of the leakage testing and every 24 hours thereafter until complete.

The developer shall warranty the completed work against repairs, leaks or damage for a period of one year from the acceptance of the work by the County. Eleven months after acceptance of the work by the County, the developer shall have the interior and exterior of the tank inspected by an independent testing agency and provide a written report to the County in accordance with AWWA D102 Coating Steel Water-Storage Tanks. Damage, leaks, or other deficiencies noted during the inspection shall be corrected by the developer.

4.8.8 Disinfection and Volatile Organic Compound Sampling and Testing

All tanks shall be disinfected and tested in accordance with AWWA C652 Standard for Disinfection of Water-Storage Facilities and the applicable State Health standards. After disinfection, prior to acceptance by the utility purveyor, and prior to placing the tank into service, water from the facility shall be tested for coliform and volatile organic compounds by an independent testing agency. The test procedures and test results shall comply with the requirements of the Nevada Division of Environmental Protection Bureau of Safe Drinking Water and other appropriate regulatory agencies. Written test results shall be submitted to the County a minimum of two working days before placing the tank into service.

4.9 Treatment Facilities

Treatment facility design, capacity, and reliability shall comply with the requirements of NAC 445A. The location and design of treatment facilities shall consider topography, soil conditions, and potential hazards such as fire, earthquake, and flood. Treatment facility plans and specifications shall be submitted to the Nevada Division of Environmental Protection Bureau of Safe Drinking Water for review and approval. Following written approval of the treatment facility by the Nevada Division of Environmental Protection Bureau of Safe Drinking Water, plans and specifications shall be submitted to the Engineering Division and Public Works Department for review and approval.

4.10 Controls and Alarms

Control systems, including telemetry shall be above surface grade in suitable lockable and vandal-proof housings, or inside buildings. Telemetry shall be provided for all controls and alarms. All telemetry units shall communicate status with the water purveyor's central computer at a location designated by the water purveyor. At a minimum, the following alarms and signals shall be provided:

Water Storage Tanks:

1. High Level Alarm
2. Redundant Float High Level Alarm
3. Low Level Alarm
4. Radio Failure Alarm
5. Power Failure Alarm
6. Intruder Alarm (roof and manways)
7. Radio Telemetry Unit (RTU) Intruder Alarm

Water Supply Wells:

1. Well Pump Running
2. High Pressure Alarm
3. Primary Power Failure Alarm
4. Intruder Alarm (wellhead, hatches, building doors)
5. Radio Failure Alarm
6. Generator Start/Running
7. Generator Fail to Start
8. High and Low Chlorine Level Alarm

Booster Pump Facilities:

1. Pump Running
2. Generator Start/Running
3. Generator Fail to Start
4. Radio Failure Alarm
5. Primary Power Failure Alarm

6. High Pressure Alarm
7. Intruder Alarm (building doors and hatches)
8. High and Low Chlorine Level Alarm

4.11 Springs

Springs shall not be allowed as a source of water for public water systems.

4.12 Record Drawings

Record drawings shall be submitted to the Engineering Division prior to acceptance of facilities or improvements. Record drawings shall comply with the requirements of Section 2.2.19 Record Drawings.

4.13 Operations and Maintenance Manual

Four copies of an operations and maintenance manual shall be submitted to the Engineering Division and Public Works Department upon completion of construction and prior to acceptance of facilities or improvements, including transmission and distribution mains, wells and water storage tanks. The operations and maintenance manual shall comply with the requirements of NAC 445A.6667 and contain the following as a minimum:

1. Listing of emergency telephone numbers for utility purveyor
2. Priority calling list
3. List of abbreviations
4. General narrative of the facility
 - a. Introduction
 - b. Objectives of the facility
 - c. Facility design criteria
5. Operating instructions
 - a. Facility description
 - b. Emergency operation (discussion of potential facility failures and procedures for responding to emergency operations)
6. Operating records
7. Monitoring and treatment processes
8. Maintenance instructions
 - a. General instructions
 - b. Maintenance records
 - c. Maintenance of motors and drives
 - d. Maintenance of pumps
 - e. Maintenance of treatment/process equipment
 - f. Maintenance of valves
 - g. Maintenance of instrumentation and meters

9. Facility safety
 - a. General
 - b. Confined spaces
 - c. Electrical safety
 - d. Explosion hazards
 - e. Process facilities
 - f. Pump rooms
 - g. Collecting samples
 - h. Equipment set-up and performance tests
 - i. General safety considerations
10. Appendices as required
 - a. Permits
 - b. Figures and drawings

4.14 Facility Start-Up

The developer shall commission all systems including wells, pumps, tanks, and equipment to verify performance, function, and correct operation by performing procedures to activate, startup, adjust, test, and demonstrate the system in operating order in accordance with the approved plans and specifications and inspection and test requirements of the utility purveyor. To insure that the work is ready for full-time operation, the developer shall include procedures for the verification, balancing, calibration, witness testing, documentation, and inspection by equipment manufacturers. The developer shall also provide training of utility operators. Facility start-up and operator training shall be completed prior to acceptance by the utility purveyor.

Start-up shall be conducted as follows:

1. The Engineering Division and Public Works Department shall be notified in writing 45 days before complete facility operation is to occur. The developer shall start up and operate the facility on a complete full time basis beginning on the indicated date. The developer shall provide a mechanic, electrician, instrument engineer, representatives of manufacturers of equipment, and other personnel to adjust, repair, and correct deficiencies during start-up. The developer shall conduct all tests and inspections required by the utility purveyor.
2. Following start-up, the utility purveyor will take over operation and maintenance duties.
3. The developer or their representative shall submit documentation of test reports and calibration results to the Engineering Division and Public Works Department during start-up.
4. Prior to start-up, the developer shall submit to the utility purveyor affidavits stating that the equipment has been properly installed, tested, and adjusted. The affidavit shall contain the following wording:

“The (Name of Equipment) has been properly installed, tested, adjusted, lubricated, and calibrated, and is ready for full time operation. The installation has been inspected and been found to be in accordance with our (the manufacturer’s) standards and requirements.”

5. The developer shall provide training to utility operators which shall include a demonstration of the operation, maintenance, and safety procedures for all facilities. Training shall not be conducted during start-up.

4.15 Posting Security for Tanks, Wells, and Booster Stations

The developer shall post a deposit or letter of credit on a form acceptable to the County in the amount of \$25,000 with the County before the County will issue a notice of completion for the water tank, well, and/or booster station. The County will hold this deposit or letter of credit until the developer completes the eleven month inspection and corrective work. If the developer does not conduct the inspection at eleven months or does not correct damage, leaks or other deficiencies noted during the inspection, the County may use the deposit or letter of credit to complete this work.

4.15 References

1. "AWWA A100 Standard for Water Wells," American Water Work Association, Denver, Colorado.
2. "AWWA D102 Standard for Coating Steel Water-Storage Tanks," American Water Work Association, Denver, Colorado.
3. "ANSI/AWWA C 105/ A21.5-05 American National Standard for Polyethylene Encasement for Ductile Iron Piping for Water and Other Liquids," American Water Work Association, Denver, Colorado.
4. "AWWA C150/A21.50 American National Standard for the thickness Design of Ductile Iron Pipe," American Water Work Association, Denver, Colorado.
5. "AWWA C151/A21.51 American Nation Standard for Ductile Iron Pipe, Centrifugally Cast in Metal Molds or Sand-Lined Molds, for Water or Other Liquids," American Water Work Association, Denver, Colorado.
6. "AWWA C504 Standard for Rubber Seated Butterfly Valves," American Water Work Association, Denver, Colorado.
7. "AWWA C506 Standard for Backflow Prevention Devices - Reduced Pressure Principle and Double Check Valve Types," American Water Work Association, Denver, Colorado.
8. "AWWA C509 Standard for Resilient-Seated Gate Valves, for Water and Sewerage Systems," American Water Work Association, Denver, Colorado.
9. "AWWA C651 Standard for Disinfecting Water Mains," American Water Work Association, Denver, Colorado.
10. "AWWA C652 Standard for Disinfection of Water-Storage," American Water Work Association, Denver, Colorado.
11. Hydraulic Institute Standards, Hydraulic Institute, 9 Sylvan Way, Parsippany, New Jersey 07054-3802.
12. "Nevada Administrative Code Chapter 445 A - Public Water System Design, Construction, Operation and Maintenance," Division of Health, Bureau of Health Protection Services, Carson City, Nevada.
13. "Recommended Standards for Water Works," Great Lakes Upper Mississippi Board of State Public Health and Environmental Managers.
14. "Standard Specifications for Public Works Construction," Regional Transportation Commission of Washoe County, Washoe County, City of Sparks, City of Reno, Carson City, City of Yerington.
15. State of Nevada Division of Water Resources, Regulations for Drilling Water Wells.

Table 4.2. Water System Improvement Checklist.

1. Water System Model and Report

- proposed water system
- impacts on existing facilities
- drawings and maps to illustrate the water system
- listing of all assumptions
- appendices with detailed results of analyses
- recommendations for type, size, location, and phasing of water system improvements
- any other data that may be required to present the results of the water system analyses
- tabulation of water system pressures for all simulations and pressure contour maps for all simulations
- extended period and fire flow simulations for the proposed system and the ultimate system at master plan build-out for the maximum allowable densities in the most critical areas of the system

2. Water System Improvement Plans

final wet stamped construction drawings, specifications, design calculations, and cost estimates for:

- water mains (include plan and profile, stationing, topography, all existing features and work to be performed, etc.)
- wells
- pumping facilities
- treatment facilities
- storage tanks
- buildings
- appurtenant facilities

3. Water Rights

water rights of an acceptable quantity, form, and character including:

- recorded quitclaim deed
- conveyance of Title Report
- Change Application as required

4. Permits, Easements and Agency Approvals

- recorded easements for all improvements as shown on the drawings
- final permits from all agencies
- NDEP Bureau of Safe Drinking Water written approval

Table 4.2. Water System Improvement Checklist (Continued).

5. Water Supply Wells

____ Hydrogeologic Evaluation which includes:

____ a detailed map showing well location

____ a summary of available hydrogeologic information including reports, logs of nearby wells, water quality data, and any other relevant information

____ a description of the proposed plan for exploration, testing and well construction

____ a statement of anticipated water demand from the well

____ recommendations for well construction, drilling, test pumping, and water sampling and analysis

____ Well Design Report which includes:

____ daily drillers logs and inspectors daily reports

____ lithologic logging and sampling logs

____ temperature, resistivity, specific conductance logs

____ well cross section

____ maximum day demand

____ average day demand

____ water quality sampling and testing

____ casing material

____ well screen

____ gravel pack design

____ drilling method

____ plumbness and alignment tests

____ test pumping program and results (yield and efficiency testing)

____ development

____ disinfection program

____ final wet stamped construction drawings, specifications, and design calculations for the well and appurtenant facilities

6. Pumping Facilities

____ well pump design criteria, construction drawings, and specifications including:

____ casing diameter

____ depth of well

____ sanitary seal

____ static water level

____ pumping level

Table 4.2. Water System Improvement Checklist (Continued).

- ___ pump intake setting
 - ___ required pump discharge
 - ___ total dynamic head at required discharge
 - ___ maximum pump speed (revolutions per minute)
 - ___ minimum motor horsepower
 - ___ minimum efficiency
 - ___ plan and section drawings
 - ___ piping drawings and details
 - ___ projection of capital and operation and maintenance costs

 - ___ booster pump design criteria, construction drawings, and specifications including:
 - ___ type of pumps (end suction, split cased, can, etc.)
 - ___ required pump discharge
 - ___ total dynamic head at required discharge
 - ___ maximum pump speed
 - ___ minimum motor horsepower
 - ___ minimum efficiency
 - ___ plan and section drawings
 - ___ piping drawings and details
 - ___ chlorination facility design, drawings, and specifications
 - ___ building design and drawing, and specifications
 - ___ stand-by generator design and specifications
 - ___ electrical diagrams, schematics, drawings, and specifications for all facilities
 - ___ final wet stamped construction drawings, specifications, cost estimates, and design calculations for all well pumps, booster pumps, chlorination facilities, buildings, and stand-by generators
- 7. Water Storage Tanks**
- ___ design report
 - ___ geotechnical investigation and foundation design
 - ___ water system model and sizing analysis
 - ___ fire flow requirements
 - ___ average day and peak day requirements
 - ___ equalization requirements

Table 4.2. Water System Improvement Checklist (Continued).

____ emergency storage

____ final wet stamped construction drawings, specifications, and design calculations

8. Annual Operation and Maintenance Costs

____ water distribution system

____ wells and pump stations

____ storage tanks

____ telemetry and controls

9. Operation and Maintenance Manual

____ water distribution system

____ wells and pump stations

____ storage tanks

____ telemetry and controls



Division 5 Sewer Systems

DIVISION 5 SEWER SYSTEMS

5.1 Design Criteria

The following design criteria shall govern the design of sewage collection systems. The intent of these criteria is to provide safe, adequate, and dependable sewage service without excessive maintenance costs. All sanitary sewer systems and facilities shall comply with the requirements of this manual, the ASCE Manual of Engineering Practice No. 60 “Gravity Sanitary Sewer Design and Construction,” Appendix D Sewer Facilities in Title 20, and the “Recommended Standards for Wastewater Facilities”.

Improvement plans for sewage collection systems and facilities must be reviewed and approved by the Engineering Division and the local entity which will accept and maintain the improvements. Refer to Division 2 Improvement Plans for sewer system improvement plan requirements.

5.1.1 Sewer Study and Main Analysis

Sewer mains shall be analyzed and designed to provide capacity for the ultimate tributary population based on existing land uses and densities plus the full master plan build-out. For County facilities, the calculations and report shall be submitted to the Engineering Division to be forwarded to Public Works Department a minimum of 30 days in advance of submittal of improvement plans, and shall be approved by the County prior to preparation of improvement plans. Some projects, such as commercial building permits, may be exempt from the sewer study and main analysis requirements; contact the Public Works Department **or** sewer purveyor for a determination.

The sewer study and main analysis shall include a narrative report submitted to the Engineering Division with maps and calculations addressing the following:

1. Area of Project
2. Tributary areas outside project
3. Adjacent areas
4. Contours extending three hundred feet minimum beyond the project or as needed to evaluate localized tributary areas or as required by the Public Works Department
5. Main layout, pipe size and slope, material type, external loads, pipe deflections
6. Predicted design average flows and design peak hourly flows at major junction points including flow coming from outside the project area
7. Direction of flow
8. Zoning used to predict flows
9. Special areas such as hospitals, schools, large office or industrial buildings, etc.
10. Non-domestic waste being introduced into the system such as industrial process wastes, cooling water, etc., and the types of pretreatment devices to be provided
11. Boundaries of areas within the project which are tributary to points of major flow
12. Floodplains
13. Scale
14. Predicted design average flow and design peak hourly flows from each area

15. Peaking factors
16. Cumulative design average flow and design peak hourly flow at major junction points
17. Pipe capacities and depths of flow for design average flow and design peak flow
18. Design calculations (hydraulics, trench design, design velocities, calculated velocities, etc.)
19. Depth to groundwater

The sewer study and main analysis shall clearly discuss the proposed sewer system, impacts on existing facilities, drawings and maps to illustrate the proposed system, listing of all assumptions, appendices with detailed results of analyses, recommendations for type, size, location, and phasing of sewer system improvements, and other data that may be required to present the results of the sewer system analyses. The existing sewer system capability shall be determined through engineering analyses, and proposed improvements shall be evaluated and justified through technical means by the design engineer.

5.1.2 Design Requirements

5.1.2.1 General Criteria

The average flow from residential units shall be based on an average daily residential rate of 250 gallons [1 equivalent dwelling unit (EDU) = 250 gallons per day]. The number of EDU's may be used to determine the flow from commercial and industrial areas. The number of EDU's for commercial and industrial areas shall be calculated in accordance Minden-Gardnerville Sanitation District (MGSD) ordinances for projects within the MGSD service area, or in accordance with the Douglas County Development Code, Appendix D for all other areas. If EDU counts are not available, peak daily flows for commercial and industrial property shall be as approved by the sewer purveyor and Public Works Department. Peaking factors shall be in accordance with the "Recommended Standards for Wastewater Facilities," and as approved by the Public Works Department.

The depth of flow in the sanitary sewer pipes through 15 inches in diameter shall not exceed $0.5D$ where D is the nominal diameter of the pipe. The depth of flow in a sanitary sewer greater than 15 inches in diameter shall not exceed $0.75D$ where D is the nominal diameter of the pipe. Sewage collection systems for a given area shall be sized to carry the design peak hourly flow from the entire tributary area at build-out even if the tributary area is not within the project boundaries.

Gravity sewer mains shall be considered at capacity when the design peak hourly flow for sanitary sewer pipes through 15 inches in diameter is at $0.5 D$, where D is the nominal diameter of the pipe, and $0.75D$ for sanitary sewer pipes greater than 15 inches in diameter. Depth of flow in gravity sewer mains shall not exceed $0.75D$.

5.1.2.2 Depth of Pipeline Installation

All collection systems shall be designed at a depth to comply with the following requirements:

1. Lateral and side sewer installations shall have a minimum of 3 feet of cover at ditch flowlines and at the curb and/or property line, and a minimum slope of 1/4 inch per foot to the back 1/3 of each parcel. The invert elevation at the property line shall be shown on the plans.
2. Avoid conflict with existing and proposed utilities.

3. Pass under water lines with a minimum vertical clearance of 18 inches in the event that the two utilities should cross.
4. Gravity sewer mains and laterals shall be designed at an elevation lower than all water facilities, water mains, fire hydrant laterals and water services and shall have adequate horizontal and vertical separation from all utilities.
5. Buoyancy of sewers shall be considered, and flotation of the pipe shall be prevented with appropriate design and construction where high groundwater conditions are anticipated.
6. A minimum cover of 6 feet over the crown of the public sewer main as measured from surface course or finished grade is required. Depth on dead end lines may be less than 6-feet.

5.1.2.3 Pipe Size and Material

Collector sewers, mains, interceptors, and laterals shall be sized using accepted hydraulic analysis techniques for design peak hourly flows.

Sewer mains shall be solid wall polyvinyl chloride (PVC) plastic pipe, SDR 35, in accordance with ASTM D3034. Class 165 PVC pipe in accordance with AWWA C900 Standard for Polyvinyl Chloride (PVC) Pressure Pipe may be used for force mains. If Class 165 PVC pipe is used, it shall be green in color. No change in pipe material will be allowed between manholes. Truss pipe is not permitted.

Pipe shall be designed for the internal and external loads that will be applied. The Marston's formula, as outlined in ASCE Manual of Engineering Practice No. 60 "Gravity Sanitary Sewer Design and Construction," shall be used to determine the load placed on the pipe by the backfill. For flexible conduits the maximum load allowable shall be determined by pipe deflections computed by the Iowa Deflection Formula (Or Spangler's Formula). Flexible conduits shall be designed to not exceed a maximum deflection of five (5) percent of the nominal pipe diameter under the installation conditions. The five (5) percent deflection shall not be exceeded at thirty (30) days after completion of backfill. Seismic design shall be incorporated in all areas where sewer lines cross a fault.

5.1.2.4 Utility Clearances

Sanitary sewers shall be located to minimize potential contamination and disturbance of water supply. Additional requirements may be imposed by the local utility companies, and the Nevada Division of Environmental Protection Bureau of Safe Drinking Water. See NAC 445A "Water Controls."

The water and sewer pipeline joints shall be spaced an equal distance from the crossing point. No joints shall be located within 10 feet of the crossing point. Sewer pipe materials shall not change between manholes.

Concrete or cement slurry encasement of the sewer main or water main will not be allowed in lieu of required clearances.

5.1.2.5 Pipe Slope

Pipe slope shall not be less than the slope at which the flow velocity is at least 2 feet per second when flowing full using a Manning "n" of 0.013. In no case shall slopes be less than those shown in Table 5.1. Sewer pipe slopes which permit sewage velocities greater than 15 feet per second shall require special provisions be made to protect against displacement by erosion and impact. Sewers shall have a uniform slope between manholes.

Dead end sewers shall end in a manhole. Dry sewers which will be extended at a future date and installed without a manhole shall be surveyed for line and grade by a Nevada licensed professional engineer or land surveyor prior to backfill. Refer to Section 5.1.10 Manholes for requirements for installation of a stub for dry sewers. The design engineer shall place a note in a prominent location on each plan/profile sheet indicating the as-built requirement.

Oversized sewers will not be approved by the Public Works Department to justify using flatter slopes. If the proposed slope is less than the minimum slope of the smallest pipe which can accommodate the design peak hourly flow at a depth of 0.75D, the actual depths and velocities at design average flow, design maximum day flow, and design peak hourly flow for each design section of the sewer shall be calculated by the design engineer and be included with the sewer report and main analysis.

Table 5.1 Minimum Slopes for Sewer Pipe.

Pipe Diameter (inches)	Number of Equivalent Dwelling Units Served	Minimum Slope
4	Residential Sewer Laterals	2.00%
8 ^{1,3}	10 or less	1.00%
8 ^{2,3}	11-20	0.60%
8 ²	Above 20	0.40%
10		0.30%
12		0.22%
15		0.15%
18 and up		2 fps @ full flow
Deviations from this table shall be applied for as a variance and special provisions may be required by the County and/or the sewer utility.		

Notes:

- When 10 or less EDU's are served, such as a blind cul-de-sac or other location where no extension of the sewer is possible, the Public Works Department may allow a 6-inch pipe with a minimum slope of 1.00%.
- When 8 inch pipe cannot be laid at the required minimum slope, an engineered system may be allowed where calculations demonstrate the ability of the system to meet a flow velocity of at least 1.5 feet per second (fps). Engineered systems will be allowed only with prior written approval from the Public Works Department taking into consideration the calculations submitted and signed by a Nevada licensed professional engineer and the alternatives presented including, but not limited to, the availability to increase the slope of the pipe, the length of the sewer line, the location of the sewer line, the feasibility and accessibility for maintenance and cleaning of the sewer line and other criteria which would be of impact on the County or sewer utility once the sewer line has been constructed and accepted.
- Minimum pipe slope for dead end sewers, whether temporary or permanent, shall be five tenths (0.5%) of a percent if it can be shown by calculations that the velocity in the pipe is 2 feet per second or greater.

5.1.3 Steep Slope Protection

Sewers on 20 percent slopes or greater shall be anchored securely with concrete, or equal, anchors spaced as follows:

- Not over 36 feet center to center on grades 20 percent and up to 35 percent;
- Not over 24 feet center to center on grades 35 percent and up to 50 percent; and
- Not over 16 feet center to center on grades 50 percent and over.

5.1.4 Pipeline Bedding and Backfill

Class A backfill used as bedding shall comply with the requirements of Table 200.03.02-I from the Standard Specifications for Public Works Construction for dry trenches (no free standing water), and Table 5.2 shown below for wet trenches (free standing water).

Dry trenches shall have a minimum of four inches of bedding material, and wet trenches shall have a minimum of six inches of bedding material under the pipe. Bedding material shall be brought up in four-inch lifts to the center of the pipe. In wet trenches, cutoff walls (water stops) shall be constructed to prevent the piping of water in the bedding material, and the native soil conditions shall be evaluated to determine if a filter fabric wrap of the bedding material is needed to prevent migration of native soils into the bedding material. The design of the cutoff walls (water stop) shall be submitted to the Engineering Division with the improvement plans.

Each lift shall be compacted by an approved method. Bedding material shall be used for collector sewers, mains, interceptor sewers, and laterals. Typical trench sections shall be as shown in the Standard Details.

Table 5..2 Bedding Material for Wet Trenches.

U.S. Standard Sieve Size	Percent by Weight Passing
1-1/2"	100%
1"	50-90%
3/4"	30-70%
3/8"	10-40%
No. 4	5-25%
No. 200	0-10%

The Engineering Division may consider modifications from the specified bedding gradations if requested prior to construction to allow review by the Engineering Division. The review of proposed modifications to the bedding gradations will take into account the proposed bedding gradation and the conditions and gradation of the surrounding natural soils. Modifications, if approved by the County, will not relieve the developer or contractor from the responsibility of providing and guaranteeing a proper installation.

5.1.5 Length of Open Trench in Street Areas

No trench shall be left open or uncovered overnight in a developed area. In undeveloped areas, no trench shall be opened more than 300 linear feet in advance of where backfilling and surfacing have been completed. Surfacing shall mean crushed stone trench topping and may mean temporary or permanent asphalt concrete resurfacing, if required. All surfacing requirements shall conform to applicable County requirements. If the work is delayed on the whole, or part of the project, and excavations are left open for more than three (3) consecutive days, then the contractor shall backfill the excavations and temporarily repave over the excavation area, the trench shall not be opened until the contractor is ready to proceed with the work. If the contractor neglects or fails to completely refill excavations and temporarily repave over the excavation within twenty-four (24) hours after notice to do so, then the County shall be authorized to temporarily surface the excavations and the costs shall be charged to the contractor. The contractor shall at all times provide for public access by permitting traffic to pass through the construction area. All driveways are to remain passable between the hours of 4:00 p.m. and 8:00 a.m. throughout construction.

5.1.6 Dewatering

Dewatering, sufficient to maintain the groundwater level at or below the surface of the trench bottom or base of the bedding course, shall be accomplished prior to pipe laying and jointing of sewer pipe. The dewatering operation shall be carried out so that it does not destroy or weaken the strength of the soil under or alongside the trench. The normal water table shall be restored to its natural level in such a manner as to not disturb the pipe and its foundation.

Water pumped from excavations shall be disposed of by the contractor in such a manner as will not cause injury to public or private property or constitute a nuisance or menace to the public. At all times, the manner employed to discharge and to dispose of water pumped from an excavation shall be subject to the approval of the County and the appropriate permitting agency (i.e. Nevada Division of Environmental Protection - Bureau of Water Pollution Control, U.S. Army Corps of Engineers, Nevada State Lands, Division of Water Resources). All surface waters shall be prevented from entering open ditches or excavations by proper grading of the ground surface in the vicinity of the excavation.

5.1.7 Pipeline Installation

All pipe shall be laid true to line and grade as shown on the approved plans. The underground installation of all PVC gravity sewer pipe shall be in accordance with ASTM Specification D2321, and the "Standard Specifications for Public Works Construction."

5.1.8 Location and Alignment

All sanitary sewers shall be placed within right-of-way dedicated for public streets unless the use of easements is approved by the Engineering Division. Horizontal and vertical clearances shall comply with the requirements of Section 5.1.3.4 Utility Clearances. The location of sewer lines in public rights of way shall conform to the Standard Details.

When sanitary sewers are to be installed in existing streets, factors such as curbs, gutters, drainage ditches, sidewalks, traffic conditions, pavement conditions, future street improvement plans, and existing utilities shall be considered by the design engineer when selecting the sewer location and alignment.

The minimum width of easements shall be 20 feet. Other factors such as side slopes and structures within the easement may require additional width. If a main is installed within an easement, temporary maintenance access with a minimum width of 12 feet may be required in accordance with Section 3.10.14 Improved Maintenance Access. Permanent maintenance access in accordance with the requirements of Section 3.10.14 Improved Maintenance Access may be required by the County or utility purveyor.

Horizontal alignment shall be straight lines between manholes. Sanitary sewers shall not be curved.

5.1.9 Manholes

Manholes shall be placed at the intersections of all sanitary sewer lines, at the terminal end of all collector lines, and at all angle points and grade changes. Manholes shall be located outside wheel path where possible in collector and arterial roads, no clean outs will be permitted on public sewer mains, interceptor sewers, or collector sewers.

Manholes shall conform to the Standard Details. Construction note shall state "No Steps to be installed in manhole".. Straight pipe runs shall have a minimum 0.1 foot elevation drop across the manhole. Side inlets shall have a minimum 0.2 foot of elevation drop to the outlet of the manhole. When two pipes with different diameters intersect, the crown elevations of the two pipes shall match where they enter the manhole. Eighteen inch long stubs shall be installed and capped at manholes for sewer mains which may be extended in the future. Manholes at the exit points of force mains shall be polymer manholes

(Armorock or similar). Polymer manholes shall extend down stream of force main exit point one manhole per diameter of force main in inches.

Table 5.3. Maximum Distance Between Manholes

Diameter of Pipe (inches)	Maximum Distance Between Manholes (feet)
8 to 12	400
15 to 24	500
Greater than 24	600

A drop structure shall be used at manholes where the invert of the incoming pipe exceeds by 2 feet the elevation of the outgoing pipe, the drop shall not exceed 8 feet at any manhole unless approved by the sewer purveyor. The drop line shall be constructed inside of the manhole and attached to the manhole as shown on the standard detail. A clean out shall be provided in the manhole. The drop connection shall enter the manhole at an elevation 0.10 foot higher than the invert of the outgoing pipe.

When the difference in elevation between the incoming sewer and the manhole invert is less than 2 feet, the manhole invert shall be filleted and channeled to prevent deposition of solids. The drop connection shall be constructed in accordance with standard detail requirements for manhole installation. Supporting calculations for hydraulic efficiency through manholes that do not meet the above requirements shall be submitted to the department for approval. Drop manholes shall be sixty inches (60") in diameter.

5.1.10 Laterals

Laterals shall conform to the Standard Details. As a minimum, the lateral shall extend from the sewer main or collector to the edge of public right-of-way or public utility easement, whichever distance is greater, and at least 5 feet beyond the edge of pavement. Laterals shall have a minimum slope of 2% as required by Uniform Plumbing Code, unless an exception as allowed in the Uniform Plumbing Code is approved by the Engineering Division.

The standard detached single family residential lateral size shall be 4 inches. Schools, commercial establishments and other developments expected to contribute sewage flows greater than an equivalent residential unit shall be served by a sewer lateral sized using accepted hydraulic analysis techniques for the design peak hourly flows. Plan and profiles of laterals shall be submitted for developments of this nature. In addition, the service sewer shall be sized according to requirements of the Uniform Plumbing Code and determinations by the Engineering Division. A manhole shall be installed at the main for all laterals 8 inches and larger. Sewer service laterals shall not be connected to existing manholes for laterals smaller than 8 inches. Sewer service laterals may be connected to a parallel sewer main which is connected to an existing interceptor manhole.

If the service has less than 3 feet of cover measured from the gutter flow line, or bottom of drainage ditch, epoxy lined ductile iron shall be used. In all other cases, the service lateral pipe shall be SDR 35 PVC or approved equal.

When sanitary sewers are constructed as part of subdivision improvements, a lateral shall be constructed to each lot. Each parcel shall be served by a separate sewer service lateral. If the property is located such that service is available from both a line located in an easement and a line located in a right-of-way, the lateral shall be placed in the right-of-way. No service laterals shall be located such that future on-site construction will result in the line being in such proximity to a water well, water main or service that applicable health standards will be violated.

Clean outs shall be provided at the property line, and in locations and at a spacing as required by the Uniform Plumbing Code. In addition to a clean out, a sewer lateral observation tee shall be installed at the property line for all commercial or industrial services. Clean outs within the right-of-way, or which otherwise may be subjected to traffic shall include a box and cover rated for HS-20 traffic loading.

5.1.11 Stream and Ditch Crossings

Crossing details of pipe, piers, anchorage, transition coupling, etc., shall be shown on a large scale detail sheet. For main or lateral sizes 18 inches and smaller, epoxy lined ductile iron pipe shall be used under the full stream or ditch width, and 10 feet on each side; HDPE pipe of a class approved by the Engineering Division may be used for force mains. For main or lateral sizes larger than 18 inches, the pipe used shall be approved by the Engineering Division.

All stream and ditch crossings shall have minimum clearance of 5 feet between the stream bottom and top of pipe. A firm base shall be provided for the pipe bedding. The plans shall specify that all soft or organic material within the stream banks shall be replaced with select imported backfill. If the pipe must cross above the stream or ditch, reinforced concrete piers of adequate depth shall be located as necessary for adequate support of the pipe. The pipe shall be held in cylindrical cradles, formed in the tops of the pier and held down by stainless steel straps, with stainless steel anchor bolts of adequate size. Cushion material shall be placed between the pipe, clamps, and support. Special consideration shall be given to protecting the pipe during stream flooding and scour. A scour analysis shall be provided when required by the Engineering Division.

Stream and ditch crossings and construction methods shall comply with the appropriate regulations and be approved by the appropriate agency (Nevada Division of Environmental Protection, Nevada Department of Fish and Game, Nevada State Lands, and the Corps of Engineers).

5.1.12 Boring or Jacking

All pipe, except RCP, which is bored or jacked shall be placed in a welded steel conductor pipe of sufficient diameter to allow adjustment of the carrier pipe to grade. The inside diameter of the conductor pipe shall not be less than 6 inches greater than the outside diameter of the carrier pipe. Spacers around the full circumference of the pipe shall be strapped to the carrier pipe with stainless steel straps, redwood skids are not permitted. The method used for installing the carrier pipe in the conductor pipe shall be approved by the Engineering Division.

County or State of Nevada encroachment, site improvement, or right-of-way occupancy permits shall be obtained for all boring or jacking work within or under the agency's respective rights-of-way.

5.1.13 Testing

The Engineer of Record shall be responsible for ensuring that all required tests are performed and submitted to the County. The Engineer of Record shall notify, in writing, the Engineering Division a minimum of two working days prior to all tests on sewer lines.

The contractor shall furnish all necessary labor, materials and equipment and shall perform specified tests for each and every length of sewer and each item of appurtenant construction as outlined below, and in accordance with the "Standard Specifications for Public Works Construction." When other underground utilities are to be installed as a part of the construction or as a part of a larger project or subdivision related to the sewer installation, testing shall be conducted after all other utilities have been installed, and all compaction has been completed, in the area of the new sewer main and laterals. This does not preclude the contractor from also conducting testing at earlier times to insure to itself that the mains were acceptably installed prior to other utility work in the area. All tests shall be performed under the direct

observation of the utility company representation. All remedial work required to correct construction deficiencies discovered as a result of tests or inspections shall be accomplished by the contractor in a manner approved by the Engineering Division and at the sole expense of the contractor. Portions of the original construction which require remedial work shall be completely retested and/or re-inspected following the attempted correction or repair by the contractor.

Prior to final acceptance by the County, all sewer mains and appurtenances shall be subjected to a test or tests to determine their degree of air tightness and a test or tests to ascertain the correctness of their horizontal and vertical alignment. Before a test is performed, the pipe installation shall be cleaned.

The contractor shall furnish an inflatable spherical rubber ball of a size that will inflate to fit snugly into the pipe to be tested. The ball shall be placed in the uppermost manhole on the pipe to be cleaned, and water shall be introduced behind it. The ball shall pass through the pipe with only the force of the water impelling it. All debris flushed out ahead of the ball shall be removed at the first manhole where its presence is noted. In the event cemented or wedged debris or a damaged pipe shall stop the ball, the contractor shall remove the obstruction and/or make necessary repairs. Debris shall not be washed into existing sewer mains, but shall be pumped or vacuumed and disposed of at an approved location.

5.1.13.1 Sewer Main Television Inspection

All sewer mains shall have a color television inspection prior to acceptance by the County and prior to paving, if applicable. All sewer mains and manholes shall be clear of debris prior to televising. Debris shall not be washed into existing sewer mains, but shall be pumped or vacuumed and disposed of at an approved location. The contractor or developer shall furnish the County with a digital recording of the television inspection listing the distance from the nearest downstream sanitary sewer manhole to each wye or tee. Eleven months after acceptance by the County, and prior to expiration of the warranty period, all sewer mains shall be re-televised, and the contractor or developer shall furnish the County with a recording of the television re-inspection.

5.1.13.2 Deflection Test

The contractor shall conduct a deflection test on all sewer lines except laterals **prior to paving**. Perform deflection testing in accordance with the “Standard Specifications for Public Works Construction.”

5.2 Wastewater Pump Stations and Force Mains

5.2.1 General

Pump stations are not permitted where a gravity connection can be made to an existing gravity sewer main. Temporary pump stations may be considered on a case-by-case basis by the Engineering Division only after all pertinent information has been submitted to the County. The design of pump stations shall be in accordance with these requirements. Pump stations shall not have areas requiring routine or preventative maintenance, or normal operations, designated as a confined space. Pump station design shall comply with the requirements of this manual and the “Recommended Standards for Wastewater Facilities.”

Suitable land area for the pump station installation, operation, and maintenance, including access, shall be provided and dedicated to the County. All pump stations shall be fenced with a minimum 6 foot high fence with a three-foot man-gate and a double 8-foot (16-foot total) swinging gate which complies with the Douglas County Development Code.

The site access, size and layout shall provide adequate room for maintenance of the facility, including removal of pumps. The wet well shall be located so that it is directly accessible to a 35-foot Vactor type truck with the nose of the vehicle over the wet well.

Adequate overhead clearance shall be provided over the entire wastewater pump station site so that maintenance equipment does not interfere with overhead utilities or structures. In general, pump stations shall not be sited where existing overhead interferences exist.

The pump station site shall be designed for the appropriate loadings, but shall not have a structural section less than 4 inches of asphalt concrete and 6 inches of aggregate base course. Access to pump stations shall be provided by temporary maintenance access in accordance with the requirements of Section 3.10.14 Improved Maintenance Access. Permanent maintenance access in accordance with the requirements of Section 3.10.14 Improved Maintenance Access may be required by the County or utility purveyor.

Exterior lights shall be provided to adequately light the equipment area. The lights shall be shielded to prevent spillage onto the neighboring properties. Exterior pump station lighting shall be fitted with day/night sensors for automatic on-off operation and shall also be fitted with manual on-off switches.

5.2.2 Design Report

An engineering report shall be submitted to the County for all pump stations a minimum of 30 days in advance of submittal of improvement plans, and shall be approved by the County prior to preparation of improvement plans. The engineering report shall address the following:

1. Description of the area to be served by the pump station
2. A sewer study and main analysis in accordance with Section 5.1.2 Sewer Study and Main Analysis for the area tributary to the pump station
3. A discussion of alternatives to a pump station
4. Operation and maintenance requirements shall be identified and discussed
5. Cost estimates for the pump station and appurtenance facilities, including operation and maintenance costs.
6. Transient flow and water hammer conditions and recommendations to mitigate transient flow and water hammer conditions.

The engineering report shall clearly discuss the proposed sewer pump station, impacts on existing facilities, drawings and maps to illustrate the proposed system, listing of all assumptions, appendices with detailed results of analyses, recommendations for the type, size, and location of the improvements, and other data that may be required to present the results of the pump station analyses.

5.2.3 Improvement Plans

Improvement plans for pump stations shall comply with the requirements of Section 5.1.1 Improvement Plan Requirements. In addition, the improvement plans shall include construction specifications, and all drawings for the pump station including electrical, mechanical, civil and structural. Plans shall clearly show the elevation of high water at the site, and the maximum elevation of wastewater in the collection system if pumping ceased due to power failure. The maximum hydraulic gradient in downstream gravity sewers shall be shown when all pumps are in operation. Odor control shall be incorporated into the design and shown on the improvement plans.

A design review of pump station buildings and a building permit are required. The building site shall be landscaped and provided with an irrigation system with automatic controls. The irrigation system shall have backflow prevention and shall have automatic drains to prevent freezing, and shall comply with the requirements of Section 2.2.11.3 Permanent Erosion Control Standards. Access to the building site shall be provided by temporary maintenance access in accordance with the requirements of Section 3.10.14 Improved Maintenance Access. Permanent maintenance access in accordance with the requirements of Section 3.10.14 Improved Maintenance Access may be required by the County or utility purveyor.

5.2.4 Flows

The pumping system including the discharge piping and mains shall be designed to pump a minimum of three times the average daily flow with the largest pump out of service. Multiple pumps or sequencing of pumps shall be considered when one pump cannot operate at the minimum required efficiency over the range of expected flow conditions.

5.2.5 Pump Station Requirements

Wastewater pump stations shall be the submersible pump type. The presence of hydrogen sulfide and other corrosive gases, greases, oils, and other components present in sewage shall be considered in the selection of materials and equipment. Wet wells shall be considered a hazardous environment, classified as National Electric Code Class I, Division I for explosive gases.

The design of pump stations shall meet all federal, state and local requirements. Individual equipment lockouts shall be provided for all motorized equipment.

Submersible pump stations shall be designed so that pumps can be removed and replaced without dewatering the wet well or disconnecting piping in the wet well. All submersible lift stations shall be provided with dedicated permanently mounted motorized cranes that are capable of removing the pumps. All check valves and isolation valves shall be located in a separate valve pit. Submersible pumps shall be explosion proof.

All electrical controls and the motor control center shall be located outside the wet well, be readily accessible, and be protected by a conduit seal or other appropriate measures which comply with the National Electric Code, to prevent the atmosphere of the wet well from gaining access to the control center. The seal shall be located so that the motor may be removed and electrically disconnected without disturbing the seal. Refer to the "Recommended Standards for Wastewater Facilities," for additional requirements for submersible pump stations.

5.2.5.1 Wet Well

Pump station wet wells shall be constructed of precast reinforced concrete and shall be circular. Wet wells that are installed within the groundwater table shall be adequately designed to prevent flotation. Wet well size and depth shall be as required to accommodate the influent sewer, provide for adequate pump suction pipe or pump submergence as recommended by the pump manufacturer and to provide adequate volume to prevent the excessive cycling of pumps. Partitioning the wet well is one option available to accommodate future growth requirements. Partition designs are subject to the approval of the sewer utility.

Wet wells shall have sloping sides to form a hopper at the bottom of the wet well in all areas outside of the dedicated sump. Slopes shall be approximately 1 horizontal to 1 vertical. Square corners should be avoided. The flat portion of the wet well floor shall be minimized and no greater than necessary for proper installation and function of the pump inlet.

5.2.5.2 Interior Linings and Waterproofing

Wet well interior walls and ceilings shall be lined with an epoxy coated material (raven 404, sewer shield, Sauerisen, or equivalent) that is suitable for immersed wastewater service. The lining shall be completely resistant to hydrogen sulfide and sulfuric acid. The liner shall be easily cleanable and sufficiently durable so that it can be washed with a high pressure water hose. The liner shall be light in color. Materials used for interior liners shall be subject to the approval of the sewer utility. Wet wells shall also have a waterproofing system installed on the exterior of the wet well.

5.2.5.3 Wet Well Access

Wet well access shall be through a top slab opening with aluminum hatch cover and frame. The top slab access hatch shall be a minimum of 36 by 36 inches in size and as large as necessary to allow removal of equipment from the wet well. All access hatches shall be torsion assisted and all components shall be non-corrosive. An aluminum safety grate system that complies with OSHA regulations shall be provided under the access hatch.

5.2.6 Pump Station Piping

Piping shall be fusion-bonded epoxy-lined and coated steel piping with flanged joints or epoxy lined ductile iron with flanged joints as required by the utility. All fasteners used for joining pipes shall be stainless steel. Pump isolation valves shall be eccentric or full port plug valves. Isolation valves shall permit the removal or maintenance of pumps and check valves without affecting the operation of remaining pumps. Swing check valves shall have a purging lever and shall be provided on each pump discharge. The individual pump discharge shall connect into the main header horizontally to prevent grit buildup in the check valve.

Wastewater pump stations that are designed to pump 100 gpm or more shall have additional pipe, valves, fittings and couplings as necessary to permit bypassing of the lift station including the wet well and pumps. The provisions shall include a separate manhole preceding the wet well that can be used as a sump for a temporary pump, a valve on the gravity line inlet to the wet well to shut off flow to the wet well, and bypass piping including an isolation valve, check valve, and quick connect cam-lok fitting enabling the temporary pump to pump directly into the existing force main.

Sewage air relief valves shall be provided at high points in the discharge line. Air relief valve vaults shall have a floor drain with trap and return line to the wet well.

Pressure gauges shall be provided on discharge piping. Pressure gauges shall be liquid filled direct reading 4 ½ inch dial with a ½ inch connection. All gauges shall include an oil isolation diaphragm for isolation of the gauge from the wastewater. Gauge connection ports shall be included on all pump discharge mains and suction lines. The connection port shall include a coated service saddle or a welded thread-o-let for tapping of the main, Type 316 stainless steel nipples, a stainless steel spring return ball valve to the closed position, and a ½-inch Swagelok “QF” series female NPT stem with protector cap.

5.2.7 Pumps

At least two pumps shall be provided for all pump stations. A minimum of three pumps shall be provided for stations with an average daily flow of more than 1 million gallons per day (MGD). All pumps shall have the same capacity. Pumping capacity shall be such that the station can handle peak hourly sewage flows with one pump out of service. Pumping capacity shall also accommodate low flows as well as the design peak hourly flow from build-out conditions. The pumps shall be placed so that they will operate under a positive suction head during normal operation. A check valve and shutoff valve shall be located on the discharge line of the pump.

Submersible pumps shall be manufactured by Flygt or ABS, no substitutions, with 3/16 inch stainless steel double rail system, and energy efficient motors. Pumps shall be of the non-clog centrifugal type and shall have pump suction and discharge openings at least four-inches (4") in diameter, be designed to handle sewage, and shall not operate in excess of 1750 revolutions per minute (RPM). Pumps shall be capable of passing spheres of at least 3 inches in diameter. Pumps shall be equipped with mechanical seals, inspection and clean out ports on the suction piping immediately prior to the front head of the pump and on the discharge portion of the volute, and a bleed valve assembly to the highest portion of the volute or seal housing. One extra set of all mechanical seals shall be provided to the Engineering Division upon completion of the project and prior to acceptance by the County. Pneumatic ejectors will not be permitted. Suction line velocities shall not exceed 5 fps and discharge piping velocities shall not exceed 8 fps.

5.2.8 Overflow Prevention

Provide emergency pumping capability in accordance with "Recommended Standards for Wastewater Facilities" unless system overflow prevention is provided by adequate storage capacity. If adequate storage capacity is not provided, provide a dedicated in-place stand-by generator. Refer to Section 5.2.9 Stand-by Generator for stand-by generator requirements. If adequate storage capacity is provided, provide a transfer switch and cam-lok connectors for a plug in portable generator. Cam-lok connectors shall be Crouse Hinds E1016 Series receptacles and plugs.

5.2.9 Stand-by Generator

A stand-by engine generator shall be provided with automatic starting and load transfer equipment to operate the entire pump station load during power failure, unless automatic overflow into a gravity sewer line can be provided at an elevation that insures no back-ups in the collection which would cause surface overflows or backing-up into connected buildings. Consideration shall be given to control of odors and noise. The generator shall be fueled by diesel or by natural gas as approved by the County and utility purveyor. The storage tank shall have capacity to provide a 24-hour continuous run time. Generators for County facilities shall be manufactured by Cummins Power Generation. Generators shall be provided with the following:

1. Weather-protective (NEMA Type 4), sound proofed (QuietSite Level 2 enclosure with silencer), vandal-proof and lockable housing with access to all engine and generator components
2. Above ground vandal-proof double walled storage tank, and concrete pad for secondary containment
3. Engine block heater and thermostat to allow for instantaneous start-up at -30 degrees Fahrenheit
4. Shutdown safeguards, gauges and indicator lamps for over temperature, low oil pressure, overspeed and overcrank
5. Automatic battery charger installed on the hot side of the transfer switch enabling the batter to maintain its charge when idle
6. Walkway platform and safety guards for generators larger than 75 kilowatt to provide maintenance access to engine compartment
7. Power command digital display generator set control for generator set monitoring, metering, and control system which includes Level 2 Control, front panel security key, digital display, network communications module, load monitoring module and relay module

8. Cummins Power Generation OTPC Power Command Automatic Transfer Switch to monitor the primary source, signal generator set startup, automatically transfer power, and return the load to primary power source once the power utility returns and is stabilized

The generator site shall be fenced with a minimum 6 foot high fence which complies with the Douglas County Development Code. Access shall be through a 16 foot wide double gate. The generator site shall be landscaped and provided with an irrigation system with automatic controls. The irrigation system shall have backflow prevention and shall have automatic drains to prevent freezing, and shall comply with the requirements of Section 2.2.11.3 Permanent Erosion Control Standards. Access to the building site shall be provided by temporary maintenance access in accordance with the requirements of Section 3.10.14 Improved Maintenance Access. Permanent maintenance access in accordance with the requirements of Section 3.10.14 Improved Maintenance Access may be required by the County or utility purveyor.

5.2.10 Electrical

Electrical systems and components (motors, lights, cables, conduits, switch boxes, control circuits, etc.) in raw sewage wet wells, or in enclosed or partially enclosed spaces where hazardous concentrations of flammable gases or vapors may be present, shall comply with the National Electrical Code Requirements for Class 1, Group D, Division 1 locations. In addition, equipment located in the wet well shall be suitable for use under corrosive conditions. Each flexible cable shall be provided with a watertight seal and separate strain relief. A cased disconnect switch located above-ground shall be provided for all pumping stations. When such equipment is exposed to weather, it shall meet the requirements of weatherproof equipment NEMA 3R or 4. All County and publicly owned facilities shall be provided with 480 volt a. c., three phase power; an engineering analysis shall be provided with all requests for an exemption to three phase power.

The following items shall be included in the electrical system and components:

1. The service shall be sized to allow all station fixtures, equipment and all pumps to operate together. Motor starters greater than 10 HP shall be soft start and soft stop.
2. Control panels shall be enclosed in NEMA 4X enclosure panels and shall include adequate space for mounting of controls and instrumentation. Standard control panel layout for two or more pumps shall be provided with the following section of panels:
 - a. Power company metering and main breakers
 - b. Automatic transfer switch
 - c. Circuit breakers and starters for unit heaters, portable pump, main wastewater pumps, fans, compressors, etc., station transformer and 240/120 volt single phase panel board
 - d. Flow recorder and pump controls including cycle counters and running time clocks
 - e. Solid-state reduced voltage starters for constant speed main wastewater pumps
3. Lightning protection and transient voltage surge suppression devices shall be provided on all phases of commercial power
4. Battery backup with two hours reserve for the telemetry system
5. A 120 volt single phase GFCI duplex outdoor weatherproof outlet shall be provided at the electrical panel for potable tools

5.2.11 Controls and Alarms

Wet well liquid levels shall be controlled by a transducer with a redundant back up float switch for a high water alarm. These systems within the wet well shall be located to minimize the turbulent influences of flow into the wet well on the control of liquid level. Ultrasonic or other similar types of level control systems may be used in lieu of the standard bubbler system with the approval of the sewer utility.

Control systems shall be configured to allow inspection, service, repair or replacement from the ground surface through the wet well hatch or lid, without confined space or wet well entry. The controls shall be located away from the turbulence of incoming flow and pump suction. In all stations, provisions shall be made to automatically alternate the pumps in use. All controls and telemetry shall be above surface grade in suitable lockable and vandal-proof housings. Telemetry shall be provided for all controls and alarms. Control panels shall be equipped with start counters and hour meters for all pumps.

Alarm systems shall be provided for pumping stations. Alarm systems shall be of a radio telemetry type and shall include a sending unit at the lift station and a receiving unit at a County designated facility. The telemetry system shall be compatible and of like type with those units presently in use by the County Engineering Division. As a minimum, the following alarms shall be provided:

1. High wet well
2. Flooded dry well
3. Loss of power
4. Loss of seal water
5. Wastewater pump failure (by check valve limit switch in addition to motor overload)
6. Low wet well level

5.2.12 Force Mains

A minimum flow velocity of 3 feet per second shall be maintained in the force main during pump operation. The minimum force main diameter shall be 4 inches. An automatic air relief valve designed for operations in sanitary sewage systems shall be placed at high points in the force main to prevent air locking. Vacuum relief valves shall be provided as necessary to relieve negative pressures on force mains. The force main configuration and head conditions shall be evaluated to determine the need for and placement of vacuum relief valves.

The plans shall call for a pressure test at 150 percent of the pipe pressure class or a minimum of 150 pounds per square inch, whichever is greater, in accordance with the "Standard Specifications for Public Works Construction." The plans shall also call for a magnetic locating tape printed with "SANITARY SEWER FORCE MAIN" to be installed in the trench 1 foot above the pipe, and carsonite markers along the surface of the pipeline alignment at maximum 200 foot intervals or as required by the Engineering Division.

The force main shall be constructed of either epoxy lined Ductile Iron Pipe in conformance with AWWA C150/A21.50 American National Standard for the thickness Design of Ductile Iron Pipe and C151/A21.51 American National Standard for Ductile Iron Pipe, Centrifugally Cast in Metal Molds or Sand-Lined Molds, for Water or Other Liquids, PVC pipe in conformance with AWWA C900 Standard for Polyvinyl Chloride (PVC) Pressure Pipe, or High Density Polyethylene Pipe (HDPE) in conformance with ASTM D3035 "Standard Specification for Polyethylene (PE) Plastic Pipe (DR-PR) Based on Controlled Outside Diameter." Trenching and installation of the force main shall be as required for a water main.

Force mains shall enter the gravity sewer system at a point not more than 2 feet above the flow line of the receiving manhole.

Private force main laterals shall convert to gravity flow at the property line prior to connecting to the County collection system.

5.2.13 Flow Metering

The pump station shall have one Siemens Mag Flow 5100W magnetic flow meter with a 4-20 milli-amp (MA) output (remote readout) installed on the force main in a water-tight vault. The flow meter vault shall be separate from the wet well and check valve vaults. The flow meter shall include a submersibility kit, and shall be capable of operating in submerged conditions. The vault shall be equipped with a sump pump and flood alarms (remote readout), and a drain line back to the wet well.

5.2.14 Flood Protection

Pumping station structures, access to all spaces, electrical panels, mechanical equipment, and motors shall be at an elevation of at least 1 foot above the 100 year base flood elevation, or protected from a 100-year flood.

5.2.15 Applicable Design Codes

The following list of codes and standards are to be followed as a minimum:

1. International Building Code
2. International Residential Code
3. Uniform Plumbing Code
4. Uniform Mechanical Code
5. National Electrical Code
6. NFPA Article 820
7. National Fire Code
8. Occupational Safety and Health Standards
9. Hydraulic Institute Standards

5.2.16 Start-up and Operation

Prior to approval or acceptance by the County or respective utility purveyor, the developer or owner shall commission all systems including pumps, controls, and equipment to verify performance, function, and correct operation by performing procedures to activate, startup, adjust, test, and demonstrate the system in operating order in accordance with the approved plans and specifications and inspection and test requirements of the utility purveyor. To insure that the work is ready for full-time operation, the developer shall include procedures for the verification, balancing, calibration, witness testing, documentation, and inspection by equipment manufacturers. The developer shall also provide training of the respective utility purveyor operators. Facility start-up and operator training shall be completed prior to acceptance by the utility purveyor.

Start-up shall be conducted as follows:

1. The Engineering Division and utility purveyor shall be notified in writing 45 days before complete facility operation is to occur. The developer shall start-up and operate the facility on a complete full time basis beginning on the indicated date. The developer shall provide a mechanic, electrician, instrument engineer, representatives of manufacturers of equipment, and other personnel to adjust, repair, and correct deficiencies during start-up. The developer shall conduct tests and inspections required by the utility purveyor.
2. Following start-up, the utility purveyor will take over operation and maintenance duties
3. The developer or their representative shall submit documentation of test reports and calibration results to the utility purveyor during start-up.
4. Prior to start-up, the developer shall submit to the utility purveyor affidavits stating that the equipment has been properly installed, tested, and adjusted. The affidavit shall contain the following wording:

“The (Name of Equipment) has been properly installed, tested, adjusted, lubricated, and calibrated, and is ready for full time operation. The installation has been inspected and been found to be in accordance with our (the manufacturer’s) standards and requirements.”
5. The developer shall provide training to respective utility purveyor operators which shall include a demonstration of the operation, maintenance, and safety procedures for all facilities. Training shall not be conducted during start-up.

5.2.17 Operations and Maintenance Manual

Four copies of an operations and maintenance manual shall be submitted to the respective utility purveyor upon completion of construction and prior to acceptance of facilities or improvements, pump stations, and force mains. The operations and maintenance manual shall contain the following as a minimum:

1. Listing of emergency telephone numbers for utility purveyor
2. Priority calling list
3. List of abbreviations
4. General narrative of the facility
 - a. Introduction
 - b. Objectives of the facility
 - c. Facility design criteria
5. Operating instructions
 - a. Facility description
 - b. Emergency operation (discussion of potential facility failures and procedures for responding to emergency operations)
6. Operating records
7. Monitoring and treatment processes
8. Maintenance instructions
 - a. General instructions

- b. Maintenance records
 - c. Maintenance of motors and drives
 - d. Maintenance of pumps
 - e. Maintenance of treatment/process equipment
 - f. Maintenance of valves
 - g. Maintenance of instrumentation and meters
9. Facility safety
- a. General
 - b. Confined spaces
 - c. Electrical safety
 - d. Explosion hazards
 - e. Process facilities
 - f. Pump rooms
 - g. Collecting samples
 - h. Equipment set-up and performance tests
 - I. General safety considerations
10. Appendices and required
- a. Permits
 - b. Figures and drawings
11. Record Drawings on mylar film and AutoCAD dwg files

5.3 On-Site Sewage Disposal Systems

The location, design, materials, construction and inspection of on-site sewage disposal systems (i.e. septic systems and engineered systems) shall comply with Douglas County Development Code and Nevada Administrative Code Chapter 444, "Regulation Governing Individual Sewage Disposal Systems."

5.4 Wastewater Treatment Facilities

Treatment facility design, capacity, and reliability shall comply with the requirements of the "Recommended Standards for Wastewater Facilities," the Nevada Division of Water Resources, and the Nevada Division of Environmental Protection. Plans for all wastewater treatment facilities shall be approved by the Nevada Division of Environmental Protection, the Engineering Division, and the utility purveyor. The location and design of treatment facilities shall consider topography, soil conditions, and potential hazards such as fire, earthquake, and flood.

The use of package treatment plants will be reviewed by the Engineering Division on a case-by-case basis. Package plants shall comply with Nevada Administrative Code, Chapter 445A and must be approved by the Board of County Commissioners.

5.5 References

1. Great Lakes Upper Mississippi River Board of State Public Health and Environmental Managers, “Recommended Standards for Wastewater Facilities”.
2. Hydraulic Institute Standards
3. Uniform International Building Code, International Code Council, Inc.
4. Joint Task Force of the American Society of Civil Engineers and the Water Pollution Control Federation, “American Society of Civil Engineers Manual of Engineering Practice No. 60, Gravity Sanitary Sewer Design and Construction,” 1982.
5. National Electrical Code
6. National Fire Code
7. NFPA Article 82
8. Occupational Safety and Health Standards
9. Residential Building Code, International Code Council, Inc.
10. Uniform Plumbing Code
11. Uniform Mechanical Code



Division 6 Storm Drainage

DIVISION 6 STORM DRAINAGE

6.1 Statutory Authority

Title 20.100.060.C of the Douglas County Consolidated Development Code (DCCDC) provides the statutory authority for the use of this manual for drainage design. Drainage policy and development requirements are contained in Title 20.100.060.

6.1.1 Stormwater Drainage System

Stormwater drainage systems are an integral part of the development process. The planning of drainage facilities shall be included in the development process and in preparation of improvement plans.

Storm drainage planning for all development shall include the allocation of space for drainage facility construction and maintenance, which may entail the dedication of right-of-way or easements.

6.1.2 Water Rights

All drainage systems shall be planned and constructed with consideration given to the existing water rights and applicable water laws.

6.1.3 Reasonable Use of Drainage

“Reasonable Use of Drainage” is defined as providing an economically and hydraulically efficient drainage system which is demonstrated not to adversely impact downstream properties. This “Reasonable Use of Drainage” therefore allows development to occur while preserving the rights of adjacent property owners.

Downstream properties shall not be unreasonably burdened with increased flow rates, negative impacts, or unreasonable changes in manner of flow from upstream properties. Drainage problems shall not be diverted from one location to another. In the same manner downstream properties cannot block natural or existing runoff through their site and shall accept runoff from upstream properties.

Storm drainage shall not result in the alteration or relocation of a water course which will reduce the flood-carrying capacity of the water course, nor shall drainage facilities result in the damming, filling, relocating or other interference with the natural flow of surface water along any surface water drainage channel or natural water course, except as may be approved as part of the drainage study.

6.1.3.1 Increase in Rate of Flow

Development typically increases the rate of drainage flow to downstream properties due to increases in impervious area. Mitigation of these increases is generally accomplished through the use of detention and/or retention facilities. The capacity of downstream drainage conveyance systems shall be analyzed to the point of discharge and shall be based on runoff from the development as fully improved. Discharges which exceed the capacity of the conveyance to the point of discharge will not be allowed. An increase in the peak rate of flow from development shall not be allowed. Storms shall be accommodated in accordance with Section 6.1.5 Storm Runoff Detention and Section 6.6 Technical Criteria.

6.1.3.2 Change in Manner of Flow

Development tends to concentrate existing natural sheet flow into point flows at property lines. Examples of these point flows are gutter flow, storm drain outlets, and detention facility outlets. Downstream properties may experience a longer duration of storm flows, and greater flows due to a shortened time of

concentration. Discharge of point flows on downstream property can cause increased erosion at the discharge point and further downstream. Therefore, downstream facilities shall be evaluated for runoff capacity to the point of discharge. A change in manner of flow shall be mitigated to the point of discharge. Point flows shall be discharged to downstream properties at non-erosive velocities and safe depths of flow.

6.1.3.3 Diversion of Drainage

The flow of storm runoff shall be maintained within its natural or original drainage course unless reasonable use is demonstrated otherwise.

6.1.3.4 Water Quality

Storm drainage improvements shall incorporate water quality and erosion controls in accordance with the Nevada Department of Environmental Protection – Bureau of Water Quality Planning requirements, DCCDC Title 20, and accepted engineering practice. Storm drainage leaving a development may not be of a quality that will adversely affect downstream uses. Construction sites disturbing 1 acre or greater are required to obtain coverage under the NDEP State of Nevada Stormwater General Permit NVR100000. Storm drain improvements in the areas identified in the Nevada NPDES General Permit for discharges to Small Municipal Separate Storm Sewer Systems, specifically the Clear Creek watershed and Johnson Lane area are required to comply with the Douglas County stormwater management plans for these areas.

6.1.3.5 Drainage Improvements

All development shall design and construct the drainage improvements as set forth below:

1. Drainage improvements which serve only a single development shall be provided by that development.
2. All drainage related to development or improvements shall be collected and conveyed to the point of discharge.
3. Surface drainage from impervious coverage shall not cross property lines except by way of a natural watercourse, an approved drainage system within a public or private storm drain easement, or a permanent surface drainage easement.
4. Storm drain facilities shall be extended as part of a subdivision or development to adjacent undeveloped properties for future extensions.
5. Existing drainage from adjoining property shall be perpetuated through the development.
6. The outlets of all storm drain pipes that enter ditches or other drainage facilities shall be protected with rip-rap or other protection. Impacts from the 100-year flood flows shall be considered when designing the entering pipe. Channel modifications for erosion control shall be designed so that the receiving channel and entering channel will contain flows without erosion.
7. Drainage improvements shall be designed with consideration of the impacts due to sediment, deposition, scour, and debris on operation and maintenance of the facilities. All drainage improvements shall be designed to allow maintenance of the improvements.

6.1.3.6 Floodplain Management

Development within FEMA designated floodplains shall comply with DCCDC Title 20.50, and requirements of the National Flood Insurance Program (NFIP).

6.1.3.7 Low Impact Design

Low impact design practices such as vegetated swales, bioretention and permeable pavements are not required but may be considered on a case by case basis in locations deemed appropriate by the County. Low impact design practices shall be sized to treat the first half-inch of a storm event, and shall be in accordance with the Truckee Meadows Regional Stormwater Quality Management Program “Low Impact Development Handbook.” The County Engineer shall have the authority to allow low impact design practices.

6.1.4 Storm Runoff Detention

Detention is an acceptable method to reduce increases in storm runoff due to development. Temporarily detaining storm runoff can significantly reduce downstream flood hazards as well as pipe and channel requirements. Storage also provides for sediment and debris collection that reduces maintenance requirements for downstream channels and streams.

Detention storage for land development shall be required when a development increases flows. Onsite detention storage shall be sized so that developed release rates do not exceed pre-developed rates. At a minimum, onsite detention storage shall be sized to detain runoff in order to comply with all of the following release criteria:

Design Storm	Maximum Allowable Peak Discharge
2 year, 24 hour duration	pre-developed 2 year, 24 hour duration
10 year, 24 hour duration	pre-developed 10 year, 24 hour duration
25 year, 24 hour duration	pre-developed 25 year, 24 hour duration
100 year, 24 hour duration	pre-developed 100 year, 24 hour duration

Douglas County may grant exemptions to the detention requirement if the project can show it meets one or more of the following criteria:

1. The development is an addition to existing building(s) provided the impervious density of the entire property does not increase by more than 10% and does not exceed a total of 10,000 square feet.
2. The development is located in an area that has a regional detention system installed, and the regional detention system is sized for and has capacity for the additional runoff.
3. The development is upgrading the downstream drainage conveyance system to an approved point of discharge to handle the increase in runoff.
4. The development discharges into a regional conveyance facility that has capacity based on build out of the drainage basin.
5. An engineering analysis demonstrates that detention will adversely impact downstream conveyance or property.

6.1.5 Storm Runoff Retention and Infiltration

Storm runoff retention and infiltration has been used to eliminate the need for constructing outlet structures and for ease of construction. Problems with retention basins and infiltration facilities have

included perpetual maintenance requirements, soil expansion, siltation, decreasing infiltration capacity and insect abatement. Retention or infiltration systems are acceptable as a storm drainage mitigation measure only if the system has adequate maintenance provisions and at least one of the following criteria can be met:

1. There are no downstream facilities to convey site runoff.
2. The project is located in the Lake Tahoe Basin and is approved by the Tahoe Regional Planning Agency,
3. The design engineer demonstrates that retention/infiltration is the only feasible option and Douglas County approves the concept.
4. Retention facilities may be equipped to pump to a public storm drain system after the storm has passed if natural infiltration rates are not acceptable. All stormwater flowing under pressure shall convert to gravity flow at the property line before entering the public system.

6.1.6 Drainage Facilities Maintenance

All drainage facilities shall be designed to minimize facility maintenance as well as to provide ease of maintenance and include maintenance access to the drainage facility all to the satisfaction of the entity responsible for maintenance and Douglas County. Refer to Section 6.1.8 Drainage Easements for drainage easement requirements.

The individual property owner, homeowner's association or developer shall be responsible for maintenance of all privately owned drainage facilities on their property including, but not limited to, inlets, pipes, channels, and detention/retention basins, unless otherwise required or modified by separate agreement. Should the property owner or developer fail to adequately maintain said facilities, Douglas County or the governing entity shall have the right to enter said property, upon proper notice, for the purposes of maintenance. All such maintenance costs shall be assessed against the owner(s).

If drainage facilities also convey irrigation water, maintenance shall be addressed in accordance with Division 7 and DCCDC Title 20.100.070.

6.1.7 Drainage Easements

Easements shall be provided where necessary for access and maintenance of the storm drain system. Drainage easements shall follow the criteria shown in "Division 9-Easements" of this manual.

Improvements which accept runoff from the public right of way or public property shall be dedicated as public drainage easements. Facilities which do not accept runoff from a public roadway or public property or where the drainage is conveyed through private property shall be dedicated as private.

6.2 Submittal and Review Process

The purpose of the submittal and review process is to determine whether or not the drainage plan and improvements for a given project meet Douglas County drainage requirements. These requirements include overall facility planning to assure an integrated and coordinated design as well as design standards to assure consistent design and analysis.

Drainage study submittal requirements for all land development in Douglas County are presented in the following section and summarized in Table 6.1. The submittal requirements are intended to provide the necessary information for each development, and to minimize review time. Project applicants are

encouraged to meet with the County Engineering Division and respective Town or GID to discuss drainage requirements prior to the start of the drainage analysis and design. All drainage designs and submittals shall be complete and comprehensive and include drainage reports and analyses in accordance with Section 6.3 Conceptual Drainage Study and 6.4 Technical Drainage Study.

Drainage studies shall be submitted for all development, in accordance with Table 6.1, except for single family residences on lots in a subdivision with master drainage facilities. Individual parcels one acre or greater may require a drainage study if the development of the parcel affects a drainage channel or may alter historic drainage patterns. All submitted reports shall be clearly and cleanly reproduced. Copies of charts, tables, nomographs, calculations, or other referenced material shall be legible.

6.3 Conceptual Drainage Study

A Conceptual Drainage Study is a condensed report that conceptually addresses existing and proposed drainage conditions. The conceptual drainage study shall contain sufficient information in order for the Engineering Division to make a recommendation to the appropriate Douglas County hearing body.

Table 6.1. Drainage Study Submittal Requirements.

Land Development and/or Land Action Process	Required Drainage Submittals
Tentative Parcel Map:	C ¹
Subdivision (including planned unit developments): Tentative Map	C ¹
Site Improvement Permit	T ³
Building Permit	T ³
Other:	
Special Use Permit	C ^{1,3}
Design Review	C ¹
Floodplain Modification Study	
Conditional Letter of Map Revision, Letter of Map Amendment, Letter of Map Revision, etc.	T ²
Drainage Submittal Types:	
C - Conceptual Drainage Study	
T - Technical Drainage Study	

Notes:

1. A Technical Drainage Study may be required by the Engineering Division in lieu of, or in addition to a Conceptual Drainage Study.
2. All Floodplain Modification Studies shall be prepared in accordance with FEMA requirements and the Douglas County Development Code.
3. The Engineering Division may waive this requirement.

6.3.1 Conceptual Drainage Study Outline

The Conceptual Drainage Study shall contain a brief narrative report, a calculation appendix (if required), and a drainage plan containing the following information:

- I. Introduction
 - A. Project Name, Type of Study, Study Date
 - B. Preparer's Name, Seal, and Signature (per NAC 625)
 - C. Contact Person and Telephone Number
 - D. Description of Project
 - E. Existing Site Conditions
 - F. General Location Map (8 1/2" x 11" is suggested)
- II. Existing and Proposed Hydrology (on-site and off-site)
 - A. Discuss existing and proposed drainage basin boundaries
 - B. Provide design storm (see Division 6.6.1) and 100-year return period storm flow calculations
 - C. Discuss existing drainage problems (if applicable)
 - D. Discuss existing floodplain impacts to the proposed project (if applicable)
 - E. Discuss impacts to existing irrigation facilities and capacities of existing irrigation facilities
- III. Proposed Drainage Facilities (on-site and off-site)
 - A. Discuss routing of flow in and/or around site, and location of drainage facilities.
 - B. Discuss detention requirements or other proposed runoff mitigation measures per Section 6.1.5 Storm Runoff Detention of this manual.
 - C. Discuss floodplain modifications (if applicable)
- IV. Conclusions
 - A. Compliance with the Douglas County Development Code and the Douglas County Design Criteria and Improvement Standards
 - B. Compliance with FEMA (if applicable)
- V. Exhibits
 - A. Drainage Plan

An 8 1/2" x 11" or larger legible drainage plan that covers the development area shall be submitted and bound with the Conceptual Drainage Study. The plan shall contain as a minimum the following:

 1. Locate and label development boundary
 2. Show existing and proposed drainage basin boundaries
 3. Show location of existing drainage problems
 4. Locate and label adjacent streets

3. Locate and label known 100-year floodplains
 4. Locate and label existing and/or planned local flood control facilities
 5. Identify blue-line streams
 6. Show flow paths
 7. Identify design inflow points and design outflow points and corresponding design storm and 100-year return period storm flow rates
 8. Show existing and proposed grades and topography
 9. Show time of concentration path for developed and existing conditions
 10. Show irrigation facilities
- B. Drainage Calculation Summary Sheet (1 or 2 pages)
1. Watershed flow path data including length, slope, time of concentration calculations
 2. Watershed area calculations, pervious and impervious area calculations, runoff coefficient calculations
 3. Calculation or Model Input and Output Data (pre-developed and developed conditions)
 - a. Basin Data and Physical Parameters (length, slope, Manning N, drainage area, etc.)
 - b. Channel Data (length, slope, Manning N, area, width, side slope, etc.)
 - c. Precipitation Data
 - d. Loss Rate Data
 - e. Unit Hydrograph Data
 - f. Routing Data
 - g. Storage Routing Data
 - h. Diversion Data
 - i. Other Model Input Data
 - j. Runoff Summary (peak flow, time of peak, flow routing data, storage information, etc.)
- C. FEMA Floodplain Map (show on drainage plan also)

6.4 Technical Drainage Study

The Technical Drainage Study shall discuss, **at a detailed level**, the existing site hydrologic conditions and the proposed drainage plan to accommodate or modify site drainage conditions in the final development plan for the site. The Technical Drainage Study shall address both on-site and off-site drainage analysis and improvements necessary to mitigate the impact of the proposed development on downstream properties. The technical drainage study shall include detailed calculations and documentation to support all assumptions and conclusions.

6.4.1 Technical Drainage Study Contents

The Technical Drainage Study shall be in accordance with the following outline and contain as a minimum the information listed:

- I. Title Page
 - A. Project Name, Type of Study, Date of Preparation, and Date of Revisions
 - B. Preparer's Name, Seal and Signature (per NAC 625)
- II. Executive Summary
 - A. Short discussion of major findings and summary of pre-developed peak runoff rates and volumes and developed runoff rates and volumes
 - B. Drainage Calculation Summary Sheet (1 or 2 pages)
 1. Watershed flow path data including length, slope, time of concentration calculations
 2. Watershed area calculations, pervious and impervious area calculations, runoff coefficient calculations
 3. Calculation or Model Input and Output Data (pre-developed and developed conditions)
 - a. Basin Data and Physical Parameters (length, slope, Manning N, drainage area, etc.)
 - b. Channel Data (length, slope, Manning N, area, width, side slope, etc.)
 - c. Precipitation Data
 - d. Loss Rate Data
 - e. Unit Hydrograph Data
 - f. Routing Data
 - g. Storage Routing Data
 - h. Diversion Data
 - i. Other Model Input Data
 - j. Runoff Summary (peak flow, time of peak, flow routing data, storage information, etc.)
- III. General Location and Development Description
 - A. Location of Property
 1. Street Location and Assessor's Parcel Number(s)
 2. City, County, State Highway and local streets within and adjacent to the development
 3. Township, range, section, 1/4 section
 4. Drainage basin(s) encompassing the development
 5. Location of development in relationship to existing drainage facilities
 6. Names of surrounding developments

7. General location map (8 1/2" x 11" is suggested)
 - B. Description of Property
 1. Area in acres
 2. Existing site conditions (buildings, drainage structures, floodplains, and other site conditions that may impact the project)
 3. General site topography, ground cover, and soil maps
 4. Existing irrigation facilities such as ditches, canals and diversion structures
 5. Adjacent and downstream developments, drainages and infrastructure
 - C. Project Description
 1. Purpose and nature of land disturbing activity; include estimated amount of grading
 2. Critical areas on the site which have the potential for serious erosion and/or sedimentation, or other drainage problems
- IV. Drainage Basin Description
- A. Off-Site drainage description
 1. Discuss and graphically illustrate historic drainage patterns (overland flow, channelized flow, points of discharge) for off-site flows which enter the project site
 2. Discuss and graphically illustrate off-site flows which enter the project site
 3. Provide map of drainage basins
 4. Discuss and document drainage basin characteristics and assumptions (topography, area, land use, coverage, soil types, erosion potential, etc.)
 5. Identify design storm and 100-year return period storm flows for each drainage basin and sub-basin impacting or impacted by the project site
 6. Discuss downstream flow paths, rates, and conveyance capacity
 - B. On-site drainage description
 1. Discuss historic on-site drainage patterns and capacity of the property (flow directions through site and at property lines)
 2. Discuss historic drainage patterns of upstream runoff
 3. Provide map of drainage basins
 4. Discuss historic drainage basin characteristics (topography, area, land use, coverage, soil types, erosion potential, etc.)
 - C. Floodplain Information
 1. Identify all FEMA regulated floodplains which impact the subject site. Locate same on drainage plan
 2. Note lowest floor and other pertinent elevation(s)

3. Floodplain/Floodway calculations where pertinent
- D. Previous Drainage Studies
 1. Identify previous drainage studies for the site, and provide a copy if available
 2. Identify previous drainage studies or previously approved projects which affect the site, and provide copies of the studies if available
- E. Discuss how the development meets the requirements for the Nevada NPDES General Permit for discharges to Small Municipal Separate Storm Sewer Systems, specifically the Clear Creek watershed and the Johnson Lane area.
- V. Proposed Drainage Facilities
 - A. General Description
 1. Discuss criteria and methodology
 2. Discuss proposed on-site drainage system plan and layout
 3. Discuss proposed off-site drainage system plan
 - B. Compliance with Regulations and Adopted Plans
 1. Discuss compliance with FEMA floodplain regulations and Douglas County Development Code, and all proposed modifications to or verifications of the FEMA regulated floodplain through the subject site
 2. Discuss compliance with rules and regulations for developments on alluvial fans (if applicable)
 3. Discuss compliance with previously approved drainage studies for the subject site
 4. Identify individually all requests for variances from the requirements of the drainage criteria
 5. Determine base flood elevation if project area is in an A flood zone
 - C. Hydrologic Criteria
 1. Provide and discuss design rainfall computations
 2. Provide and discuss design runoff computations
 3. Provide and discuss peak flow rates from off-site areas and facilities.
 4. Provide and discuss off-site limiting conditions and constraints (see Section 6.1.4.1 Increase in Rate of Flow)
 5. Provide schematic of pre- and post-development time of concentration paths and calculations
 - D. Facility Design Calculation
 1. Provide and discuss design calculations for the on-site drainage system (design storm and 100-year storm flows)
 - a. Street and ditch flow calculations
 - b. Storm drains, inlets, and ditch flow calculations

- c. Channel and culvert flow calculations
 - d. Other hydraulic structure flow calculations (trash rack, grates, etc.)
 - e. Detention storage and outlet design calculations and flows
 - f. Provide detail of control structure device
 - g. Erosion and sediment deposition and mitigation measures (see Section 6.6.5.19 Outlet Protection, Section 6.6.7 Drainage Channels and Section 2.2.11 Erosion Control Design Criteria)
 - h. Permanent stabilization description of how site will be stabilized after construction is complete (see Section 2.2.11 Erosion Control Design Criteria)
2. Discuss design calculations for the off-site drainage system that is accepting post-development runoff to the point of discharge, and impacts from same
 - a. Street flow calculations
 - b. Storm drain, inlets, and ditch flow calculations, including velocities
 - c. Channel and culvert flow calculations
 - d. Other hydraulic structure flow calculations
 - e. Alluvial fan analysis and calculations (when required)
 3. Discuss Floodplain/Floodway calculations as related to FEMA requirements and compliance with Douglas County Title 20.
 4. Discuss maintenance access and potential maintenance requirements, and maintenance responsibilities
 5. Discuss easement requirements for the proposed drainage facilities
 6. Discuss phasing of all drainage facilities
 7. Provide energy and hydraulic grade lines and calculations
 8. Evaluate sediment transport and deposition and discuss proposed mitigation.

VI. Conclusions

- A. Compliance with Drainage Laws
- B. Compliance with the Douglas County Development Code
- C. Compliance with FEMA requirements
- D. Compliance with the Douglas County Design Criteria and Improvement Standards
- E. Effectiveness of proposed drainage facilities to control storm runoff
- F. Impact of proposed development on off-site property and facilities
- G. Mitigation of impacts

VII. Appendices as required by report

6.4.2 Technical Drainage Study Plan

A detailed drainage plan(s) for the subject site shall be submitted with the Technical Drainage Study. The plan(s) shall be on a 22" x 34" or 24" x 36" drawing at an appropriate scale (a scale of 1" = 20' to 1" = 200' is recommended). The following information shall be shown on this drawing, except that the off-site drainage basin boundaries may be shown at an appropriate legible scale on an exhibit:

1. Property lines and streets (roads) including right-of-way widths within 100 feet of the development.
2. Street names, grades and widths.
3. Existing contours and proposed elevations sufficient to analyze drainage patterns extending a minimum of 100 feet past property lines of the project limits. If required by the Engineering Division, more extensive off-site topography shall be required.
4. Existing drainage facilities and structures, including ditches, storm drains, channels, street flow direction, and culverts. All pertinent information such as material, size, shape, slope, and location shall also be included.
5. Limits of existing floodplains based on Flood Insurance Rate Maps, and best available information. Provide tie to FEMA datum if all or a portion of the site is within a FEMA regulated floodplain, and base flood elevation information when available. Establish base flood elevations if not determined on FIRMs.
6. Proposed on-site drainage basin boundaries. Include off-site drainage basins if same runoff enters project.
7. Proposed future on-site and off-site flow directions and paths for design storm and 100-year storm flows at pertinent locations.
8. Proposed street and ditch flow paths and slopes. Trace peak flows leaving project site to nearest drainage facility; identify capacity and improvements, if needed.
9. Proposed storm drain locations, type, size, capacities, depth of flow, and slope. Include inlet types, sizes and locations, and manhole locations. Correlate to drainage calculations.
10. Proposed channel alignment with typical cross section. Provide street cross sections showing design storm and 100-year return period storm depth of flow.
11. Proposed culvert locations, type, size, and slope.
12. Miscellaneous proposed drainage facilities (i.e. hydraulic structures, etc.).
13. Easement widths and boundaries (existing and proposed).
14. Ditch and channel sections with lining, if required.
15. Construction details including control structure and identify construction materials.
16. Legend for all symbols used on drawing.
17. Scale, Bar Scale, North Arrow, Date Bench Mark, Title Block, Professional Engineers Signature, Seal.

18. Energy grade lines (EGL's) and hydraulic grade lines (HGL's) for storm drain and channel storm runoff.
19. Show emergency flow paths for 100-year peak storm both onsite and downstream to the point of discharge.
20. Reference cross sections on drainage plans with design calculations.

6.5 Technical Criteria

6.5.1 Hydrology

Drainage facilities shall be designed to convey the peak runoff for the 25 -year design storm. All development shall provide an emergency flow path, which follows the historical path, for a storm event with a 100-year return period.

1. Storm drain systems shall be designed for the 100-year peak storm for the following situations:
 - a. Locations where street flow is collected in a sump with no allowable overflow capacity.
 - b. Locations where the street cross-section is such that the allowable depth of flow in the street is limited to the curb height (i.e. elevated streets with negative slopes at the ROW line).
 - c. Locations where the desired 100-year return period storm flow direction is not reflected by the street flow direction during a 100-year return period storm (i.e. flow splits at intersections).
 - d. Locations where the storm drain system is accepting flows from an upstream storm drain system or branch which is designed for storm capacity which is greater than would otherwise be required. In this case the storm which results in the greatest flow shall be used.
2. Refer to Section 6.1.4.6 for additional requirements for projects located within a floodplain.
3. Where the storm drain or culvert conveys irrigation water and storm water, the storm drain or culvert shall be sized in accordance with the most restrictive of the following criteria:
 - a. for culvert or pipe up to and including the capacity if a round 48-inch pipe, 150 percent of the hydraulic capacity of the ditch,
 - b. beyond the capacity of a 48-inch round pipe, 100 percent of the hydraulic capacity of the ditch,
 - c. for the sum of the irrigation conveyance flow in the steady uniform flow condition (i.e. irrigation gates open) plus the storm runoff for the design storm event.
4. Refer to Section 7.1.2 Irrigation Ditches for sizing criteria for irrigation ditches that convey storm runoff. Elevations required to irrigate fields shall be accounted for in the design.
5. Refer to Tables 6.3 and 6.4 for street capacity limitations for the design storm and 100-year storm events.

6.5.2 Storm Runoff Determination

Storm runoff (rates and volumes) shall be determined in accordance with the following methods (other methods may be used if approved by the Engineering Division):

<u>Contributing Basin Area (A)</u>	<u>Computation Procedure</u>
A ≤ 160 Acres	Modified Rational Method, HEC-1 (SCS Unit Hydrograph or Kinematic Wave, HEC-HMS, TR-20 or TR-55
A > 160 Acres	HEC-1 (SCS Unit Hydrograph or Kinematic Wave), HEC-HMS, TR-20 or TR-55

Notes:

- 1. All storm drain pipe systems with a contributing area of ≤ 160 acres may be designed using the Rational Method or other appropriate method.**
- 2. The Modified Rational Method may be used to size detention facilities with a contributing area of ≤ 160 acres.**
- 3. HEC-RAS shall be used to generate hydraulic profiles for ditches, irrigation ditches, channels and rivers. Two dimensional modeling may also be acceptable.**
- 4. If the consultant wishes to use a hydrologic/hydraulic model not listed above submit a request in writing detailing the request to the County Engineer prior to submitting improvement plans.**

A Soil Conservation Service Type II, 24-hour synthetic rainfall distribution shall be used for storm runoff calculations. On a case by case basis, the County may allow the National Oceanic and Atmospheric Association (NOAA) Atlas 14 and other rainfall distributions that are supported by an engineering analysis.

The NOAA Atlas 14 precipitation frequency estimates for defining mean precipitation depth at a specific location shall be utilized for design purposes. Hydrometeorological data for Nevada from NOAA can also be found at NOAA's website.

6.5.3 Streets

The use of streets to convey stormwater runoff, although naturally occurring, interferes with the primary function of the street for transportation purposes. Streets are, however, an important component in the storm drainage system due to their large stormwater runoff carrying capacity obtained for little or no drainage related costs. In order to balance these two competing street uses, limits on the street carrying capacity are required based on the classification of the street related to emergency use during flood events. Streets may be used for storm drainage with the following specific limitations:

1. The allowable street capacity for different roadway functional classifications shall be determined in accordance with Table 6.2 and Table 6.3.
2. Gutters shall have a minimum slope of 0.50 percent to prevent ponding.
3. The maximum velocity of curb flow shall be 10 feet per second.
4. In a gutter that has a slope greater than 10 percent and a radius of 400 feet or less or where parking is allowed, design flow shall not exceed four inches (4") at the curb.
5. Finished floor elevations shall be a minimum of one (1) foot above the elevation of street flows. If finished floor elevations are not a minimum of one (1) foot above the elevation

of the street flow, or if the finished floor elevation is not shown on the improvement plans, then a technical drainage study shall be required before the County will issue a building permit for the affected lot.

Table 6.2. Longitudinal Street Flow – 25-year Return Storm.

Roadway Functional Classification	Design Storm Street Capacity Limitations (See Notes)
1) Collector / Arterial	A. No curb overtopping. A minimum 12 foot wide dry lane shall be maintained in each direction. In no case shall the flow of water extend more than half-way onto the lane adjacent to the curb.
2) Urban Commercial / Industrial Local Street, Urban Local Street, Rural Local Street	A. No curb overtopping. In no case shall the flow of water extend more than half-way onto the lane adjacent to the curb.

Notes:

1. If one or more of the above conditions cannot be met, the maximum depth of flow in the gutter flowline shall be less than or equal to 6 inches, or curb height, whichever is less.
2. Where no curb and gutter exists, encroachment onto adjacent property shall not be allowed.
3. Other criteria such as the Federal Housing Administration regulations may impose standards more restrictive than cited.

Use Modified Manning’s equation for gutter or triangular flow to calculate spread of water:

$$Q = 0.56 \times z/n \times s^{1/2} \times D^{8/3}, \text{ where}$$

Q = Discharge in cubic feet per second

Z = Reciprocal of cross slope

n = Manning’s coefficient for roughness (usually 0.015 or 0.016 for paved streets)

s = Average slope of gutter in feet per feet

D = Depth of water at curb in feet

Table 6.3. Street Capacity Limitations for 100-Year Storm.

Roadway Functional Classification	100-Year Return Period Storm Street Capacity Limitations (See Notes)
1. All roads	A. Residential dwellings, public, commercial, and industrial buildings shall not be inundated at the ground line. B. The product of the maximum depth (measured in feet) of flow at any point on the traveled way times the average flow velocity (feet per second) shall be less than or equal to six (6).

	C. On County designated emergency routes a minimum 12 foot wide dry lane shall be maintained, centered on the roadway, or the County may establish an allowable depth of water.
--	---

Notes:

1. For residential construction, the reference level as designated in the FEMA National Flood Insurance Program Elevation Certificate shall be located a minimum of one foot above the base flood elevation.
2. For nonresidential construction, the reference level as designated in the FEMA National Flood Insurance Program Elevation Certificate shall be located a minimum of one foot above the base flood elevation, or the construction shall be flood proofed in accordance with FEMA requirements to or above the base flood level.
3. Other criteria such as the Federal Housing Administration regulations may impose regulations more restrictive than cited.

6.5.4 Culvert Design

6.5.4.1 Culverts

Culverts shall be installed where natural or man-made drainage channels or ditches are crossed by roads.

6.5.4.2 Design Storm Frequency

All culverts shall be designed to pass the flow for the design storm as indicated in Section 6.6.1.

6.5.4.3 Minimum Size

The culvert size shall be 15 inch minimum, diameter for round pipe or an equivalent flow area for other pipe shapes.

6.5.4.4 Culvert Materials

Culverts shall be reinforced concrete pipe (RCP), except at residential driveways which may be corrugated metal pipe (CMP), in accordance with the Standard Details under roadways, and other traffic areas.

6.5.4.5 Driveway Crossing Culverts

The use of dip sections rather than culverts is encouraged where roadside ditches cross rural residential driveways.

6.5.4.6 Headwater Criteria

The maximum headwater for the design storm for culverts greater than 36" diameter or a culvert rise of 36" shall be 1.5 times the culvert height. The maximum headwater for culverts with a height of 36" or less shall be 5 feet if adjacent properties are not adversely affected. In all cases a minimum of 12 inches of freeboard at the headwall shall be provided, and the maximum headwater shall be below the bottom of the adjacent road subgrade.

6.5.4.7 Tailwater Criteria

When discharging from a pipe to a drainage facility including detention ponds, the outlet hydraulics shall be modeled such that the flow depth in the downstream drainage facility is accounted for when setting the

tailwater depth at the pipe outfall. The depth in the drainage facility may be difficult to determine due to variations in drainage and irrigation flows, and the relative invert elevations. Outlets hydraulics shall be determined based on the receiving drainage facility having a water depth of 50 percent of capacity.

6.5.4.8 Alignment

Whenever possible, culverts should be aligned with the natural channel to reduce inlet and outlet transition problems.

Where the natural channel alignment would result in an exceptionally long culvert, modification to the natural alignment may be necessary. Since such modifications will change the natural stability of the channel, such modifications shall be thoroughly investigated to prevent erosion to adjacent properties or siltation of the culvert.

6.5.4.9 Multiple Barrel Culverts

Multiple culverts may be used if available fill height or headwater constraints limit the size of culvert needed to convey the flood flow.

6.5.4.10 Inlet and Outlet Configuration

Culverts shall be designed with protection at the inlet and outlet areas. The culvert inlet shall include a headwall with wing walls or a flared end-section.

The outlet area shall also include a headwall with wing walls or a flared end-section. Where outlet velocities exceed the limitation set forth in Section 6.6.5.15 Storm Drain Outlet Protection, an energy dissipater shall be required.

6.5.4.11 Structural Design

All culverts shall be designed to withstand, as a minimum, an H-20 loading in accordance with the design procedures of AASHTO "Standard Specifications for Highway Bridges" and with the pipe manufacturer's recommendations. The minimum cover for culverts shall be 18 inches. The design engineer shall provide written certification for cover less than 18 inches.

6.5.5 Storm Drains

6.5.5.1 Storm Drain Hydraulic Analysis

A hydraulic analysis of all storm drains shall be performed and submitted to the Engineering Division as part of the Technical Drainage Report. Storm drain hydraulic and capacity analysis shall account for changes in flow conditions (open channel versus pressure flow) in the HGL and EGL calculations. Both the HGL and the EGL for the design flow shall be included in the Technical Drainage Report. Design flows shall be based on build-out conditions.

6.5.5.2 Allowable Storm Drain Capacity

The storm drain capacity calculations shall begin at the storm drain outlet and proceed upstream, accounting for all energy losses. The EGL and HGL shall be calculated to include all hydraulic losses including friction, expansion, constriction, bend, and junction losses. The available energy at all junctions and transitions shall be checked to determine whether or not the flow in the storm drain will be pressurized due to backwater effects even if the design flow is less than the full flow capacity of the storm drain.

If any section of the storm drain is pressurized due to backwater effects, then the storm drain system shall be designed to convey the design storm under surcharged or pressure flow conditions. The storm drain shall be considered surcharged when the depth of flow (HGL) in the storm drain is greater than eighty percent of full flow depth. The maximum level of surcharging for the capacity analysis shall be limited to maintaining the HGL to one foot below the final grade above the storm drain at all locations. Special site conditions that warrant additional surcharging will require locking type manhole covers or grated covers and will be reviewed on a case by case basis by the Engineering Division.

6.5.5.3 Allowable Storm Drain Velocity

The maximum velocity in all storm drains and culverts shall not exceed the erosion resisting capabilities of the conduit and storm drain system, and in no case shall exceed 15 feet per second (fps).

The minimum velocity shall not be less than 3 fps with the storm drain at half full or greater conditions.

6.5.5.4 Minimum Storm Drain Slope

The minimum storm drain slope is 0.25%. Deposition of sediment shall be evaluated and mitigated on all storm drain designs.

6.5.5.5 Manning's Roughness Coefficient

All storm drain system hydraulic calculations shall be performed using Manning's Formula. A Manning's roughness factor, or "n", shall be as defined by the specific pipe manufacturer provided that the coefficient is within the range of accepted engineering standards.

6.5.5.6 Minimum Pipe Size

The minimum pipe size for public storm inlet laterals and public storm drain mains shall be 15 inches in diameter for round pipe, or an equivalent flow area for other pipe shapes.

6.5.5.7 Minimum Cover

All storm drain pipe shall be designed to withstand, as a minimum, an H-20 loading in accordance with the design procedures of AASHTO "Standard Specifications for Highway Bridges" and with pipe manufacturers recommendations. The minimum allowable cover over the storm drain pipe shall be 18 inches. The design engineer shall provide written certification for cover less than 18 inches.

6.5.5.8 Manhole and Junction Spacing

A manhole shall be located at all changes in pipe size, direction, elevation and grade for all pipes. Maximum spacing between manholes on storm drain less than 48 inches in diameter shall be 400 feet. The maximum spacing shall be reduced if required by the entity that will maintain the storm drain. For pipes with a diameter (or rise dimension) of 48 inches and greater, the designer shall consult with the Engineering Division for location of manholes and junctions based on hydraulic and maintenance considerations. Deposition of sediment shall be evaluated and mitigated in all storm drain designs.

Standard manhole details are included in Appendix D. Precast manhole tees are not allowed where there is a change in storm drain slope or alignment or where there are intersecting storm drain mains or laterals. Pipes may be directly cast into the manhole base. Gasketed joints, locking type manhole covers, and/or grated manhole covers for pressure flow conditions may be required.

6.5.5.9 Horizontal Alignment

The horizontal alignment of storm drains shall be straight between manholes, catch basins, or curb inlets. All storm drains shall be placed within the right-of-way dedicated for public streets unless the use of easements is approved by the Engineering Division. Manholes shall be located outside of the wheel path on collector and arterial roads where possible.

6.5.5.10 Utility Clearances

Storm drains and culverts shall be located to minimize potential contamination and disturbance of water supply and sanitary sewer mains. Refer to Sections 4.5.2 and 5.1.3.4 of this manual for further direction. Additional requirements may be imposed by the local utility companies, or the Nevada Division of Environmental Protection Bureau of Safe Drinking Water. Where requirements differ, the more stringent shall apply.

6.5.5.11 Storm Inlet and Catch Basin Types, Locations, and Capacity Factors

Standard plans for approved storm inlets and catch basins are included in Appendix D. The allowable use of these storm inlet and catch basin types is presented in Table 6.4. All catch basins shall have sumps (17 inches minimum, 24 inches maximum). Allowable inlet capacity factors for each of the standard inlets and catch basins are also presented in Table 6.4. These capacity factors shall be applied to the calculated capacity of the inlets and catch basins to account for plugging from debris and sediment which decrease the capacity of the standard inlets.

Table 6.4. Allowable Storm Inlet Types and Capacity Factors.

Inlet or Catch Basin Type	Standard Detail No.	Permitted Use	Permitted Location Condition	Capacity Factor
Type 4RCurb Inlet	D06	All Streets with Curb and Gutter	Continuous Grade	0.70 (Grate) 0.80 (Curb Opening)
			Sump	0.65

Notes:

- Standard Detail Numbers refer to the Standard Details Incorporated in Appendix D.
- Capacity factor is applied to the calculated inlet capacity to account for factors which reduce actual inlet capacity.

Catch basins or inlets shall be installed at low points of vertical curves, at all street intersections, and at sufficient intervals to intake the design storm peak flow such that flows will not exceed allowable spread widths, interfere with traffic or flood adjoining property in accordance with the requirements of Table 6.2. Catch basins and inlets shall be located immediately upstream of the intersection and immediately upstream of crosswalk locations. Catch basins or inlets shall not be located within crosswalks or pedestrian ramps or in front of driveways. When storm drain pipes are connected to a catch basin, inlet, or manhole with concrete/grout, both the inside and outside of the catch basin, manhole, or inlet shall be grouted at the pipe connection.

The maximum allowable ponding for inlets in a sump condition shall comply with the street capacity requirements indicated in Table 6.2.

6.5.5.12 Sand/Oil Interceptor

Sand/oil interceptors shall be installed as set forth below:

1. When required for compliance with this manual.
2. When required by the approving authority.
3. When required by the Water Conveyance Advisory Committee.
4. On all new development in urban service areas prior to discharge to a ditch, detention pond or open water body.

Sand/oil interceptors shall comply with the following:

1. be sized to treat the first half-inch of a storm event,
2. be sized to remove 80 percent of the total suspended solids,
3. have a by-pass for flows that exceed their treatment capacity and
4. include a sampling port to sample water as it leaves the unit.
5. An annual report of the condition of the sand/oil interceptor and any maintenance performed shall be submitted to the Engineering Division annually.

Sand/oil interceptors shall be installed on private property and be maintained by the property owner. A detailed maintenance and sampling plan shall be submitted with the improvement plans. Should the property owner or developer fail to adequately maintain said facilities, Douglas County or the governing entity shall have the right to enter said property, upon proper notice, for the purposes of maintenance. All such maintenance costs shall be assessed against the owner(s). If the sand/oil interceptor is directly discharging to open ditch/slough/water body of U.S. then the applicant shall obtain NDEP and Army Corps of Engineers approval.

6.5.5.13 Storm Drain Pipe Material and Shape

The material and shape of the storm drain shall be in accordance with the “Standard Specifications for Public Works Construction.” Round, arch, elliptical, square, or rectangular rubber gasket reinforced concrete pipe (RGRCP) in accordance with ASTM C76, C506, C507 or C655C1433 or C850 shall be used for storm drain construction under roadways, other traffic areas. Rubber gaskets shall conform to ASTM C443 and C1619. Reinforced concrete pipe shall be at a minimum Class III or the appropriate class when design requires greater pipe support strength.

For storm drains less than 48-inches in diameter, plastic pipe as specified by the Nevada Department of Transportation (NDOT) Standard Specification for Road and Bridge Construction Section 708 may be used. Water tight joints per ASTM D3212 is required for all plastic pipe applications. Deflection testing per NDOT Section 605 is required for all plastic pipe. All pipe joints, structure joints, and all joints between pipes and structures shall be watertight.

For installations of less than 100-feet where RGRCP is not readily available, the contractor may use non gasketed concrete pipe with each joint wrapped in an external sealing band which meets ASTM C877 and is installed per manufacturer’s recommendations.

Other pipe materials as approved for storm drain use are permitted on private property and areas outside of roadway or traffic areas. Corrugated metal pipe within public right-of-way will only be allowed for residential driveway approaches on county roadside ditches.

6.5.5.14 Length of Open Trench in Street Areas

No trench shall be left open or uncovered overnight in a developed area. In undeveloped areas, no trench shall be opened more than 300 linear feet in advance of where backfilling and surfacing have been completed. Surfacing shall mean crushed stone trench topping and may mean temporary or permanent asphalt concrete resurfacing, if required. All surfacing requirements shall conform to applicable County requirements. If the work is delayed on the whole, or part of the project, and excavations are left open for more than three (3) consecutive days, then the contractor shall backfill the excavations and temporarily repave over the excavation area, the trench shall not be opened until the contractor is ready to proceed with the work. If the contractor neglects or fails to completely refill excavations and temporarily repave over the excavation within twenty-four (24) hours after notice to do so, then the County shall be authorized to temporarily surface the excavations and the costs shall be charged to the contractor. The contractor shall at all times provide for public access by permitting traffic to pass through the construction area. All driveways are to remain passable between the hours of 4:00 p.m. and 8:00 a.m. throughout construction.

6.5.5.15 Dewatering

Dewatering, sufficient to maintain the groundwater level at or below the surface of the trench bottom or base of the bedding course, shall be accomplished prior to pipe laying and jointing of storm drain pipe. The dewatering operation shall be carried out so that it does not destroy or weaken the strength of the soil under or alongside the trench. The normal water table shall be restored to its natural level in such a manner as to not disturb the pipe and its foundation.

Water pumped from excavations shall be disposed of by the contractor in such a manner as will not cause injury to public or private property or constitute a nuisance or menace to the public. At all times, the manner employed to discharge and to dispose of water pumped from an excavation shall be subject to the approval of the County and the appropriate permitting agency (i.e. Nevada Division of Environmental Protection - Bureau of Water Pollution Control, U.S. Army Corps of Engineers, Nevada State Lands, Division of Water Resources). All surface waters shall be prevented from entering open ditches or excavations by proper grading of the ground surface in the vicinity of the excavation.

6.5.5.16 Pipeline Installation

All storm drain pipe shall be laid true to line and grade as shown on the approved plans. The underground installation of all storm drain pipe shall be in accordance with manufacturer's recommendations and the requirements of Division 6, and the "Standard Specifications for Public Works Construction."

6.5.5.17 Location and Alignment

All storm drain pipe shall be placed within right-of-way dedicated for public streets unless the use of easements is approved by the Engineering Division. Horizontal and vertical clearances shall comply with the requirements of Section **6.6.5.10** Utility Clearances. The location of storm drain pipes in public rights of way shall conform to the Standard Details.

When storm drain pipes are to be installed in existing streets, factors such as curbs, gutters, drainage ditches, sidewalks, traffic conditions, pavement conditions, future street improvement plans, and existing utilities shall be considered by the design engineer when selecting the pipe location and alignment.

The minimum width of easements shall be 20 feet. Other factors such as side slopes and structures within the easement may require additional width. If a pipe is installed within an easement, temporary maintenance access with a minimum width of 12 feet may be required in accordance with Section 3.10.14

Improved Maintenance Access. Permanent maintenance access in accordance with the requirements of Section 3.10.14 Improved Maintenance Access may be required by the County or utility purveyor.

6.5.5.18 Storm Drain Outlet Protection

Storm drain outlets shall be designed and constructed with outlet protection for discharges to channels with unlined bottoms. Mitigation measures to protect storm drain outlets shall be included in the technical drainage study and shall be designed by a licensed engineer. The following are minimum requirements for outlet protection, but the existing soil conditions will ultimately dictate the maximum permissible velocity for designing any outlet protection:

<u>Outlet Velocity (fps)</u>	<u>Minimum Outlet Protection</u>
less than 5	Recommended Mitigation Measures per the Drainage Study
between 5 and 15	Rip-rap Protection or Energy Dissipater (see Riprap Protection at Outlets section in “Design and Construction of Urban Stormwater Management Systems” ASCE Manual No. 77)
greater than 15	Energy Dissipater

For channels with lined bottoms, the outlet discharge velocity shall not exceed the maximum allowable channel velocity without an energy dissipation structure. Specifications and drawings for the outlet protection shall be submitted with the improvement plans.

6.5.6 Drainage Channels

When open drainage channels are permitted, the potential for erosion and scour shall be determined, and submitted as part of the drainage report. Drainage channel design shall incorporate recommended mitigation measures to prevent erosion, sediment transport and sediment deposition. Flow velocities in drainage channels shall not exceed the maximum permissible flow velocities for the design storm as recommended in the ASCE Manuals and Reports of Engineering Practice No. 77, “Design and Construction of Urban Stormwater Management Systems.” Drainage channels shall be sized to provide a minimum of one foot of freeboard above the water surface elevation for the design storm peak runoff. Drainage channels that convey any FEMA flood flow shall be lined to 1 foot above the 100-year flood level.

Side slopes for unlined channels shall be 3:1 (horizontal to vertical) or flatter. Side slopes for lined channels shall be 2:1 (horizontal to vertical) or flatter. The use of rip rap as a channel lining is discouraged due to maintenance requirements. Channel linings, including blankets, shall have a minimum lifespan of five (5) years.

All drainage channels that are not located within public rights-of-way shall be located in easements dedicated to the County or the appropriate entity, and shall be provided with permanent maintenance access roads in accordance with Section 3.10.14 Improved Maintenance Access to provide access for maintenance.

6.5.7 Detention Facilities

The main purpose of a detention basin is to temporarily store runoff and reduce peak discharge by allowing flow to be discharged at a controlled rate. This controlled discharge rate shall be determined so that the rate of post-development runoff will not exceed the rate of pre-development runoff leaving the site.

Detention facilities shall be designed by and constructed by developers or local property owners. The facilities are intended to allow development by protecting a site from existing flooding conditions or to protect downstream property from increased runoff caused by development.

The following developments shall utilize private retention/detention basins to handle stormwater requirements:

- Commercial type developments (i.e. retail, business, etc)
- Industrial type developments
- Multi-family residential (i.e. apartments, condominiums, townhomes)

On lot retention/detention will not be allowed on parcels 1 acre or less in size.

6.5.7.1 Detention/Retention Design Guidelines and Standards

The following sections describe guidelines governing detention basin designs.

6.5.7.1.1 Detention Facilities

Detention facilities shall comply with the following:

1. Impounding of water for stormwater control purposes shall comply with regulations of the Nevada State Engineer for the construction of dams where pertinent.
2. The top six inches of soil in the basin shall have a maximum particle size of three (3) inches. Basins shall be seeded with a drought tolerant mix of turf grasses. Vegetation shall be established prior to acceptance by the County or local entity. Refer to Section 2.2.11.3 Permanent Erosion Control Standards for landscaping and irrigation requirements. Within the Town of Gardnerville, detention facilities shall be equipped with a fully-automatic permanent below-ground irrigation system approved by the Town of Gardnerville. A low flow concrete valley gutter shall be constructed for publicly maintained facilities. Detention basins shall be below grade unless otherwise approved in writing by the Douglas County Engineer.
3. Impacts from and to groundwater shall be evaluated and mitigated.
4. Basins shall be sited within drainage easements. Basins accepting flows from the public right-of-way will be dedicated to the public. If the basins are to be publicly maintained then they shall be on a separate parcel dedicated to the entity that will be maintaining. The use of multiple small detention/retention basins is prohibited.
5. Detention basin outlet capacity shall not exceed the pre-developed flow rate to the point of discharge. The analysis shall include inflows occurring downstream of the detention basin to the point of discharge and changes in flow conditions and hydraulics due to the use of the upstream detention basin, and shall not exceed the pre-developed flow rate (up to the design storm) for the affected property (see Section 6.1.5 Storm Runoff Detention).
6. All detention basins are required to properly function under all reasonable debris and sedimentation conditions. Sand/oil separators shall be located immediately upstream of the detention basin inlet. Refer to Section 6.6.5.12 for sand/oil separator sizing criteria.
7. In-channel detention basins shall safely pass the 100-year storm event as a minimum.
8. Detention ponds shall be designed to include provisions for security and public safety. Ponds greater than two feet in depth to the spillway elevation, or to the outlet elevation, and with side slopes steeper than 4:1, shall either be fenced or have a 15-foot wide bench

- area around the pond perimeter above the freeboard elevation. Ponds that are not fenced shall be signed that the ponds are not to be entered when water is present.
9. Basins shall be drained in not more than 48-hours after the end of the design storm. (Drain time is defined as the time from the end of precipitation until the basin is drained of 90% of design capacity). Properly designed and functional low flow outlets shall be provided in all detention basins.
 10. Design of all detention basins shall include emergency spillways which pass the 100-year storm event and are protected against erosive forces.
 11. A minimum of one foot of freeboard is required above the emergency spillway design water surface elevation.
 12. Basin discharge shall be self-regulating (passive).
 13. Inflows shall be based on build-out conditions for the tributary area within the project limit (including all phases) in accordance with the Douglas County Master Plan, and on the existing conditions for the tributary area outside the project limits.
 14. Detention basins shall have side slopes no steeper than 4:1 horizontal to vertical. Access to the basin bottom, fore bay, inlet and outlet structures and spillways shall be provided by a 9 inch reinforced concrete ramp with slope no steeper than 6:1 horizontal to vertical with a minimum width of 12 feet. Structural surfaces other than PCC or asphalt concrete may be allowed for the ramp with the approval of the County and entity that will maintain the basin.
 15. The outlet for the basin shall be placed at the flow line of the basin and not above it.

Where **retention/infiltration** has been approved, the following shall apply:

1. Infiltration rates shall be based on a minimum of three hydraulic conductivity tests at each proposed infiltration system site. The minimum acceptable hydraulic conductivity for infiltration systems is 0.5 inches per hour. The infiltration rate used in design to size the facilities shall be limited to a maximum of 50 percent of the infiltration rate determined from field tests. The retention/infiltration facility shall have adequate infiltration area to infiltrate all stormwater from the entire 25-year design storm within 48 hours after the end of the storm.
2. Retention/infiltration facilities shall be sized to contain 1.5 times the entire 25-year design storm volume for the project (not the difference between the existing undeveloped runoff volume and developed runoff volume). The infiltration rate shall not be used to reduce the required size of the retention/infiltration facility.
3. Sand/oil separators shall be located immediately upstream of the retention basin inlet. Refer to Section 6.6.5.12 for sand/oil separator sizing criteria.
4. In the case where the capacity of the retention/infiltration facility is exceeded, impacts to downstream properties shall be evaluated and mitigated. Emergency flow paths shall be provided for release of storm volumes in excess of the design storm.
5. A detailed maintenance plan shall be included with the final drainage report.
6. Analysis of soil infiltration capabilities and groundwater issues.
7. Safeguards for public protection.

6.5.7.1.2 Flow Restrictor Outlets

The flow restrictor outlet shall be sized to control discharge from a basin as set forth in Section 6.1.5 Storm Runoff Detention. Outfall from a flow restrictor shall be provided by a culvert or pipe conduit. The types of flow restrictors for parking lot detention may be under-sidewalk drains.

6.5.7.1.3 Minimum Outlet Conduit Size

The minimum conduit size for use in detention facilities is an 18-inch diameter. Orifice plates may be utilized to reduce flows from this minimum pipe size, and shall be designed to prevent floatable debris from blocking the orifice(s), and allow cleaning and maintenance during “worst case” scenarios.

6.5.7.1.4 Emergency Spillways

All detention and infiltrations facilities shall have the ability to pass 100-year return period storm event and flows in excess of the design storm without endangering the structural integrity of the facility or diverting flows from their historic drainage pattern. **Impacts to downstream properties shall be considered when siting and designing the spillway.** Spillways shall flow to historic pattern.

A detention or retention basin may have more than one spillway. If a basin has only one spillway, it shall be able to pass both the design flow and 100-year return period storm event. If the geometry of the basin site does not allow for a single spillway to serve these two flows, two spillways may be provided. The principal spillway will be designed to handle the design storm flow. For flows greater than the design storm flow, the emergency spillway shall allow these greater flows to be passed safely.

6.5.7.1.5 Debris and Sedimentation

Provide for protection of the outlet works from debris and for the control and removal of sedimentation in the basin. Sedimentation effects shall be considered in design and may be reduced by the construction of debris basins upstream of the detention facility or by providing additional storage capacity in the detention facility for storage of sediment. The invert of the emergency spillway shall be set equal to or above the design storm water surface elevation.

6.5.7.1.6 Trash Racks

All outlet and inlet works shall be provided with a trash rack and cut off wall for debris and scour control. The trash rack shall provide a maximum bar spacing of 8 inch from center to center of bar. The total area of the trash rack shall allow for passage of the design outlet flow with 50 percent of the trash rack blocked.

6.5.7.1.7 Embankment Protection

Detention/Retention Pond embankments shall be protected from structural failure from overtopping. Overtopping can be caused by a larger than design inflow, or from obstruction of the low flow outlet. Embankment protection shall be provided by embankment armoring (i.e. rip-rap) or use of slopes of 5:1 (horizontal to vertical) or flatter.

6.5.7.1.8 Maintenance Requirements

All detention facilities shall be designed to minimize maintenance and to allow access by equipment and workers to perform maintenance. Any plan for development requiring the construction of these facilities shall include a plan for maintenance, enforceable against the owners of the property to be served.

6.5.7.1.9 Detention Basin Siting Guidelines

Detention basins shall be located to minimize their impact on the site and to ensure public safety. Basins shall be placed to minimize impact on public facilities (e.g. roadway and sidewalk deterioration).

6.6 References

1. American Concrete Pipe Association, "Concrete Pipe Design Manual," American Concrete Pipe Association, 1987.
2. American Iron and Steel Institute, "Modern Sewer Design," 1980.
3. American Society of Civil Engineers, "Design and Construction of Urban Stormwater Management Systems, ASCE Manuals and Reports of Engineering Practice No. 77," 1992.
4. Brater, E.F., and King, H. W., "Handbook of Hydraulics," Sixth Edition, 1982.
5. Chow, V.T., David R. Maidment, Larry W. Mays, "Applied Hydrology," Mc-Graw Hill, Inc., 1988.
6. Clark County Regional Flood Control District, "Hydrologic Criteria and Drainage Design Manual," WRC Engineering, Inc.
7. Federal Highway Administration, "Hydraulic Design of Highway Culverts," Bridge Division, Federal Highway Administration, Washington, D.C., 1985.
8. Federal Highway Administration, "Hydraulic Design Series No. 2, Second Edition, Highway Hydrology," Publication No. FHWA-NHI-02-001, October 2002.
9. Goldman, 1986 - S. J. Goldman, K. Jackson, T. A. Bursztyusky, "Erosion and Sediment Control Handbook," Mc-Graw Hill, 1986.
10. Hydrologic Engineering Center, "HEC-1 Flood Hydrograph Package, User's Manual," U.S. Army Corps of Engineers, Hydrologic Engineering Center, Davis, California, June 1998.
11. Hydrologic Engineering Center, "HEC-2 Water Surface Profiles, User's Manual," U.S. Army Corps of Engineers, Hydrologic Engineering Center, Davis, California, September 1990.
12. Hydrologic Engineering Center, "Hydrologic Modeling System, HEC-HMS, User's Manual," U.S. Army Corps of Engineers Hydrologic Engineering Center, Davis, California, April 2006.
13. Hydrologic Engineering Center, "HEC-RAS River Analysis System, User's Manual," U.S. Army Corps of Engineers Hydrologic Engineering Center, Davis, California, November 2002.
14. National Weather Service, 2004, NOAA Atlas 14 Precipitation-Frequency Atlas of the United States: Volume 1 Semi Arid Southwest (Arizona, Southeast California, Nevada, New Mexico, Utah). U.S. Department of Commerce, Silver Spring, MD.
15. National Weather Service, 1973, NOAA Atlas 2: Precipitation-Frequency Atlas of the Western United States. U.S. Department of Commerce, Silver Spring, MD.
16. Resource Concepts, Inc., "Douglas County Precipitation Study," Resource Concepts, Inc., Carson City, Nevada, October 1992.
17. Soil Conservation Service, "Technical Release 55 Urban Hydrology for Small Watersheds, 2nd Edition" Technical Information Service, Springfield, Virginia, 1986.
18. Soil Conservation Service, "Win TR-55 User Manual," Natural Resources Conservation Service, April 19, 2002.
19. The Urban Water Resources Research Council of the American Society of Civil Engineers and the Water Environment Federation, "Design and Construction of Urban Stormwater Management Systems," 1992.

20. Truckee Meadows Regional Storm Water Quality Management Program, “Low Impact Development Handbook.”



Division 7 Irrigation Facilities

DIVISION 7 IRRIGATION FACILITIES

7.1 Statutory Authority

Title 20.100.070 of the Douglas County Consolidated Development Code (DCCDC) provides the statutory authority for the use of this manual for irrigation design. Irrigation policy and development requirements are contained in Title 20.100.070. This Division does not apply to landscaping and irrigation of residential and commercial properties.

7.1.2 Irrigation Ditches

If the proposed development includes or directly impacts existing irrigation facilities, the developer shall submit an irrigation plan to the Water Conveyance Advisory Committee and to all affected towns or districts for their review and written comment.

Irrigation ditches may be used to convey storm water provided the storm water discharge is approved by the Water Conveyance Advisory Committee and the ditch has adequate capacity to convey and deliver irrigation flows plus the storm runoff for the design storm event. Through coordination with Water Conveyance Advisory Committee the design consultant shall determine irrigation flows.

7.2 Irrigation facilities standards.

A. Standards. All ditch rights-of-way must be provided access for maintenance in accordance with these standards and restrictions:

1. Cross fencing of ditches on parcels of 20 net acres and greater may be permitted upon recommendation of the water conveyance advisory committee.
2. Lots or parcels of less than 20 net acres must not be designed to require cross fencing of the ditch.
3. On parcels of less than 20 net acres, livestock access to the ditch right-of-way may be permitted as long as the integrity of the ditch bank is maintained.
4. Where ditch rights-of-way are cross fenced there must be a 16-foot-wide metal gate providing continuous access for ditch maintenance.
5. Where a project creates parcels or lots of one acre or less, underground piping for irrigation and storm drainage must be required, unless otherwise approved by the water conveyance advisory committee.
6. Where a road or driveway intercepts a ditch and its construction would restrict or prohibit access along the ditch, ramps or other facilities as approved on the drainage and irrigation plan must be provided for both the upstream and downstream faces to facilitate access by ditch maintenance vehicles.
7. The culvert installed in a ditch or ditch crossing on a road, street, alley or driveway installed as a consequence of a subdivision or parcel map must be capable of passing 150 percent of the hydraulic capacity of the ditch up to the capacity of a 48-inch culvert. Beyond the capacity of a 48-inch culvert, the culvert must be capable of passing 100 percent of the hydraulic capacity of the ditch. The installation must not change velocity in any manner which increases erosion. Erosion controls may be required to the satisfaction of the water conveyance advisory committee.
8. Piping of ditches exclusive of road, street, alley, or driveway crossings must be capable of passing at least 150 percent of the hydraulic capacity of the ditch, up to the capacity of a 48-inch pipe. Beyond the capacity of a 48-inch pipe, the pipe must be capable of passing 100 percent of the hydraulic capacity of the ditch. Piped ditches must have manholes and other points of access

to provide for routine maintenance and cleaning in accordance with the design manual. The installation must not change velocity in any manner which increases erosion. Erosion controls may be required to the satisfaction of the water conveyance advisory committee. The committee may recommend, and the final decision maker may allow, variations in the capacity of the pipe to not less than 100% of the hydraulic capacity of the ditch when supported by sound engineering principles and practical consideration.

9. When a culvert greater than 24 feet in length is installed as a consequence of subdivision or a parcel map there must be a trash rack installed on the upstream side. The trash rack must be constructed in compliance with this manual and the Standard Details for Public Works Construction.

10. A development which is entitled to water from a ditch must provide a headgate and measuring device diversion structure in the ditch, approved by the federal water master or the state engineer.

11. A development which is entitled to water from a ditch must form a homeowner's association which will be obligated to their proportionate share of the ditch's maintenance.

12. For any development with lots ten acres in size or smaller which are entitled to irrigation water, the developer must provide an irrigation management plan which designates administrative responsibility. The drainage or irrigation plan must show how water will be supplied to and tailwater collected for each lot within the development.

13. Where a ditch is piped, where water rights are transferred from a ditch or where drainage goes into a ditch, there must be a continuing responsibility to pay a proportionate share of the costs of ditch maintenance, which can be calculated in terms of the actual costs of ditch maintenance or as though the water rights were still delivered through the ditch by the owner of the water rights. This is required until a change is approved either by all parties holding water rights in the ditch or by the water conveyance advisory committee.

B. Use of the ditch right-of-way for the storage or disposal of wood, debris, garbage or other waste or any other use of the right-of-way area which impedes the access along or maintenance of the ditch is prohibited.

7.2.1 Length of Open Trench in Street Areas

No trench shall be left open or uncovered overnight in a developed area. In undeveloped areas, no trench shall be opened more than three hundred (300) linear feet in advance of where backfilling and surfacing have been completed. Surfacing shall mean crushed stone trench topping and may mean temporary or permanent asphalt concrete resurfacing, if required. All surfacing requirements shall conform to applicable County requirements. If the work is delayed on the whole, or part of the project, and excavations are left open for more than three (3) consecutive days, then the contractor shall backfill the excavations and temporarily repave over the excavation area, , the trench shall not be opened until the contractor is ready to proceed with the work. If the contractor neglects or fails to completely refill excavations and temporarily repave over the excavation within twenty-four (24) hours after notice to do so, then the County shall be authorized to temporarily surface the excavations and the costs shall be charged to the contractor. The contractor shall at all times provide for public access by permitting traffic to pass through the construction area. All driveways are to remain passable between the hours of 4:00 p.m. and 8:00 a.m. throughout construction.

7.2.2 Dewatering

Dewatering, sufficient to maintain the groundwater level at or below the surface of the trench bottom or base of the bedding course, shall be accomplished prior to pipe laying and jointing of irrigation pipe. The dewatering operation shall be carried out so that it does not destroy or weaken the strength of the soil

under or alongside the trench. The normal water table shall be restored to its natural level in such a manner as to not disturb the pipe and its foundation.

Water pumped from excavations shall be disposed of by the contractor in such a manner as will not cause injury to public or private property or constitute a nuisance or menace to the public. At all times, the manner employed to discharge and to dispose of water pumped from an excavation shall be subject to the approval of the County and the appropriate permitting agency (i.e. Nevada Division of Environmental Protection - Bureau of Water Pollution Control, U.S. Army Corps of Engineers, Nevada State Lands, Division of Water Resources). All surface waters shall be prevented from entering open ditches or excavations by proper grading of the ground surface in the vicinity of the excavation.

7.2.3 Pipeline Installation

All irrigation pipe shall be laid true to line and grade as shown on the approved plans. The underground installation of all irrigation pipe shall be in accordance with manufacturer's recommendations and the requirements of Division 7, and the "Standard Specifications for Public Works Construction."

7.2.4 Location and Alignment

All irrigation pipes shall be placed within an irrigation maintenance and access easement. The minimum width of easements shall be twenty (20) feet when piped and thirty-two (32) feet plus top width of ditch for an open channel.



Division 8 Geotechnical Engineering Reports

DIVISION 8 GEOTECHNICAL ENGINEERING REPORTS

8.1 General

Geotechnical engineering reports shall comply with the requirements of this manual and the appropriate sections of the International Building Code, International Residential Code and Douglas County Code. Geotechnical engineering reports are required if one or more of the following conditions are met:

1. Grading in excess of 5,000 cubic yards
2. As required by the County due to special or unique site characteristics
3. As required by the Douglas County Development Code for hillside grading activities
4. Active faults or sufficiently active and well-defined faults are present on the site
5. As required by the International Building Code

8.2 Geotechnical Engineering Report

The geotechnical engineering report shall include a site plan showing the location and dimensions of the property, the existing topography, proposed grading, excavations for slopes, structures, faults, building setbacks from recognized active faults, special foundation zones, locations of proposed structures, surface and subsurface drainage facilities, paved surfaces, and other pertinent features. The geotechnical engineering report shall consider soils engineering, geologic and hydrogeologic conditions. It shall present recommendations including but not limited to site grading criteria, liquefaction, foundation design, slope stability for cut and fill slopes and development near slopes, lateral earth pressure, location and effects of storm drainage, and recommendations for testing and inspection. The geotechnical report shall consider all applicable and pertinent earth conditions at the site. The relationship of the site to the regional geologic framework shall also be discussed.

The geotechnical engineering report shall be prepared, signed, and wet stamped by a professional engineer licensed in the State of Nevada. The geotechnical engineering report shall be submitted to the County prior to or concurrent with the improvement plans for the development.

8.2.1 General Requirements

The geotechnical engineering report shall consider and present the following where applicable:

1. Description of the existing site and conditions.
2. A geologic map and cross sections shall be prepared in all bedrock areas. The cross sections should be oriented to best demonstrate site geologic structure. If desired an additional larger scale map may be used to illustrate site geology.
3. All subsurface exploration locations shall be shown on a map that utilizes the grading plan as a base. They may also be shown on the geologic map. The report shall include a description of subsurface exploration methods.
4. All subsurface explorations shall have a descriptive log. The log shall, at a minimum, provide ground surface elevation, the depth of all samples, unified soils classification, depth to ground water (if encountered, or clearly indicate if no ground water was

- encountered), all geologic measurements, soil density, and description of all encountered materials.
5. Sufficient geologic measurements taken from explorations, photo lineaments, outcrop or referenced studies shall be shown on the geologic map to define the geologic structure of the project.
 6. The site earth materials and geologic structure shall be discussed.
 7. Regional geology shall be discussed.
 8. The presence of faults shall be evaluated. Table 8.1 presents the topics and contents of geologic reports on faults that should be considered.
 9. Rippability shall be considered.
 10. Large rock disposal and handling shall be discussed.
 11. Seismicity of the region and site shall be evaluated.
 12. Site grading details and specifications shall be discussed.
 13. Disposal of surplus materials shall be discussed.
 14. Soil erosive properties shall be discussed.

8.2.2 Slope Stability Considerations

The geotechnical engineering report shall, at a minimum, consider the following slope stability requirements:

1. Surface stability of slopes under saturated and unsaturated conditions shall be calculated for all slopes greater than 10 feet high.
2. All graded slopes shall be at a ratio of 2:1 (horizontal to vertical) or flatter unless steeper slopes are recommended in the geotechnical engineering report.
3. All slopes shall have a calculated safety factor of 1.50 or greater under static conditions, and a calculated safety factor of 1.1 or greater under pseudostatic conditions.
4. The geotechnical engineering report shall provide recommendations for control of erosion/surface deterioration for graded slopes.
5. All geologic structures (i.e., bedding, joints, fault surfaces etc.) shall be considered in the stability analyses.
6. Strengths utilized in the stability analyses shall be derived from laboratory tests on the material that is considered for hypothetical failure.
7. Representative geologic cross section(s) shall be developed for all slopes that have geologic structure and are analyzed for slope stability.
8. Recommendations for retaining methods shall be discussed.
9. Effects of surface water and ground water shall be discussed. Mitigation measures shall also be discussed.

8.2.3 Geotechnical Parameters

As a minimum, the geotechnical engineering report shall discuss and present soils engineering parameters as follows:

1. Geotechnical engineering studies shall be based on adequate and sufficient laboratory testing which should consist of, but not necessarily be limited to, soil compressibility, shear strength, dry density and optimum moisture content and expansion potential.
2. The potential for soil collapse and settlement shall be evaluated.
3. Subsurface explorations for the geotechnical engineering report shall be shown on a plan with a scale sufficient to describe their location.
4. Recommendations for soil removal, soil bearing pressures, foundation design, special foundation preparation requirements, retaining wall design, slope stability (deep and surface), compaction methods and specifications, suitability of soils for use as structural fill, special site or soil limitations, subgrade preparation, and other pertinent soils conditions shall be presented.
5. Liquefaction potential shall be considered where applicable or when required by the Community Development Department.
6. Potential soil erodibility and mitigation measures shall be discussed.
7. Recommendations for pavement design, and test results used in design shall be discussed.
8. Test results for soil infiltration, hydraulic conductivity and permeability rates based on laboratory or in-situ tests for all soil types present.
9. Recommendations for testing during grading and construction.

8.2.4 Rising Water Considerations

The geotechnical engineering report shall consider rising water potential as it affects the proposed development. Rising water is water that daylight as seepage, springs or flows at the earth's surface. It can be the result of landscape watering, irrigation, seasonal changes, natural rainfall and runoff or a rising ground water table. The following items shall be considered in the geotechnical engineering report:

1. All areas of fill over low permeability bedrock shall be evaluated for rising water potential. Recommendations for drainage of retaining structures shall also be presented.
2. Geologic boundaries (i.e. faults, formational contacts, etc.) shall be evaluated for rising water.
3. Subdrains shall be designed and specifications presented for control of rising water. They shall be shown on the improvement plans.
4. Recommendations to address pumping of fill during compaction shall be presented.
5. Recommendations to address water encountered in trenching operations. See also Pipeline Bedding and Dewatering in the Water, Sewer, and Storm Drainage sections of this Design Manual.

8.3 Post-Construction Report

A post-construction geotechnical engineering report shall be submitted to the County after the completion of construction as part of the record drawings for the project. The improvements will not be accepted by the County until the post-construction geotechnical engineering report is submitted and accepted by the County. The intent of the post-construction geotechnical engineering report is to document changed conditions encountered during construction, and changes from the approved soils report. The final post-construction geotechnical engineering report shall, at a minimum, contain the following information:

1. A general description of the grading operations and encountered conditions. Deviations from the design geotechnical engineering report shall be identified and explained.
2. A geologic map shall be provided which shows the record geologic conditions if conditions are different than or were not noted in the original report. It shall include mapping of faults, and geologic contacts.
3. Subdrain locations shall be shown on the record drawings.
4. Buttressed slopes shall be shown on the record drawings. If conditions other than those anticipated by the design geotechnical engineering report were encountered during grading, stability calculations shall be presented in the post construction geotechnical engineering report.
5. Over-excavated lots and the depth of soil over-excavation shall be identified in the post construction geotechnical engineering report.
6. Recommendations for mitigation of expansive soils and soluble sulfates shall be included in the post construction geotechnical engineering report.
7. Foundation design recommendations shall be in the post construction geotechnical engineering report, including seismic design criteria.
8. Results of laboratory and field tests.
9. Plan showing locations of soils tests.
10. Critical finished grades.

The post-construction report shall be prepared, signed, and wet stamped by a professional engineer licensed in the State of Nevada.

8.4 References

1. "International Building Code," International Code Council, Inc.
2. "International Residential Code," International Code Council, Inc.

Table 8.1
Contents of Geologic Reports on Faults

I. Text.

- A. Purpose and scope of investigation; description of proposed development.
- B. Geologic and tectonic setting. Include seismicity and earthquake history.
- C. Site description and conditions, including dates of site visits and observations. Include information on geologic units, graded and filled areas, vegetation, existing structures, and other factors that may affect the choice of investigative methods and the interpretation of data.
- D. Methods of investigation.
 1. Review of published and unpublished literature, maps, and records concerning geologic units, faults, ground-water barriers, and other factors.
 2. Stereoscopic interpretation of aerial photographs and other remotely sensed images to detect fault-related topography (geomorphic features), vegetation and soil contrasts, and other lineaments of possible fault origin. The area interpreted usually should extend beyond the site boundaries.
 3. Surface observations, including mapping of geologic and soil units, geologic structures, geomorphic features and surfaces, springs, deformation of engineered structures due to fault creep, both on and beyond the site.
 4. Subsurface investigations.
 - a. Trenching and other excavations to permit detailed and direct observation of continuously exposed geologic units, soils, and structures; must be of adequate depth and be carefully logged.
 - b. Borings and test pits to permit collection of data on geologic units and ground water at specific locations. Data points must be sufficient in number and spaced adequately to permit valid correlations and interpretations.
 - c. Cone penetrometer testing (CPT). CPT must be done in conjunction with continuously logged borings to correlate CPT results with on-site materials. The number of borings and spacing of CPT soundings should be sufficient to adequately image site stratigraphy. The existence and location of a fault based on CPT data are interpretative.
 5. Geophysical investigations. These are indirect methods that require knowledge of specific geologic conditions for reliable interpretations. They should seldom, if ever, be employed alone without knowledge of the geology.
 - a. High resolution seismic reflection.
 - b. Ground penetrating radar.
 - c. Other methods include: seismic refraction, magnetic profiling, electrical resistivity, and gravity.
 6. Age-dating techniques are essential for determining the ages of geologic units, soils, and surfaces that bracket the time(s) of faulting.
 - a. Radiometric dating (especially ¹⁴C).

Table 8.1
Contents of Geologic Reports on Faults (Continued).

- b. Soil-profile development.
 - c. Rock and mineral weathering.
 - d. Landform development.
 - e. Stratigraphic correlation of rocks/minerals/fossils.
 - f. Other methods — artifacts, historical records, tephrochronology, fault scarp modeling, thermoluminescence, lichenometry, paleomagnetism, dendrochronology, etc.
7. Other methods should be included when special conditions permit or requirements for critical structures demand a more intensive investigation.
- a. Aerial reconnaissance overflights.
 - b. Geodetic and strain measurements.
 - c. Microseismicity monitoring.
- E. Conclusions.
- 1. Location and existence (or absence) of hazardous faults on or adjacent to the site; ages of past rupture events.
 - 2. Type of faults and nature of anticipated offset, including sense and magnitude of displacement, if possible.
 - 3. Distribution of primary and secondary faulting (fault zone width) and fault-related deformation.
 - 4. Probability of or relative potential for future surface displacement. The likelihood of future ground rupture seldom can be stated mathematically, but may be stated in semiquantitative terms such as low, moderate, or high, or in terms of slip rates determined for specific fault segments.
 - 5. Degree of confidence in and limitations of data and conclusions.
- F. Recommendations.
- 1. Setback distances of proposed structures from hazardous faults. The setback distance generally will depend on the quality of data and type and complexity of fault(s) encountered at the site. In order to establish an appropriate setback distance from a fault located by indirect or interpretative methods (e.g., borings or cone penetrometer testing), the area between data points also should be considered underlain by a fault unless additional data are used to more precisely locate the fault. State and local regulations may dictate minimum.
 - 2. Additional measures (e.g., strengthened foundations, engineering design, flexible utility connections) to accommodate warping and distributive deformation associated with faulting.
 - 3. Risk evaluation relative to the proposed development.
 - 4. Limitations of the investigation; need for additional studies.

Table 8.1
Contents of Geologic Reports on Faults (Continued).

II. References.

- A. Literature and records cited or reviewed; citations should be complete.
- B. Aerial photographs or images interpreted — list type, date, scale, source, and index numbers.
- C. Other sources of information, including well records, personal communications, and other data sources.

III. Illustrations — these are essential to the understanding of the report and to reduce the length of text.

- A. Location map — identify site locality, significant faults, geographic features, regional geology, seismic epicenters, and other pertinent data; 1:24,000 scale is recommended.
- B. Site development map — show site boundaries, existing and proposed structures, graded areas, streets, exploratory trenches, borings, geophysical traverses, locations of faults, and other data; recommended scale is 1:2,400 (1 inch equals 200 feet), or larger.
- C. Geologic map — show distribution of geologic units (if more than one), faults and other structures, geomorphic features, aerial photographic lineaments, and springs; on topographic map 1:24,000 scale or larger; can be combined with III(A) or III(B).
- D. Geologic cross-sections, if needed, to provide 3-dimensional picture.
- E. Logs of exploratory trenches and borings — show details of observed features and conditions; should not be generalized or diagrammatic. Trench logs should show topographic profile and geologic structure at a 1:1 horizontal to vertical scale; scale should be 1:60 (1 inch = 5 feet) or larger.
- F. Geophysical data and geologic interpretations.

IV. Appendix: Supporting data not included above (e.g., water well data, photographs, aerial photographs).

V. Authentication: Investigating geologist's signature and registration number with expiration date.



Division 9 Easements

DIVISION 9

EASEMENTS9.1 Requirements

All slope improvements, water mains, sewer mains, storm drains, utilities, or storm runoff improvements shall be installed in public rights-of-way or easements granted by the Developer to the County, utility purveyor, or General Improvement District. The legal description and accompanying graphic exhibit of easements shall be prepared by the Developer. The Developer, after review and approval of the legal descriptions by the County, shall prepare easement documents for execution by the County. For utilities or facilities that cross property owned by the County, utility purveyor or GID an easement shall be obtained. Private utilities and facilities shall not encroach into a public utility easement. Any public utility may use the public Right of Way for the installation of their facilities subject to County approval without seeking an additional easement.

9.2 Easement Size

Required easement sizes are shown in Table 9.1.

Table 9.1. Required Easement Size.

Type of Easement	Minimum Easement Size (feet)
Underground Public Utility (gas, electric, telephone, cable television)	7.5 feet (along all residential road frontages) 10 feet (along all commercial road frontages) 5 feet (along all side and rear lot lines) ¹
Storm Drainage & Irrigation Channels (open drainage channels)	32 feet plus top width of ditch
Storm Drainage & Irrigation (underground conveyance)	20 feet ²
Water Lines, Sewer Lines	20 feet ²
Slope	Limits of slope plus 20 feet at the top of slopes that are greater than 15 feet in height. Limits of slope plus 20 feet at the bottom of slopes when the bottom of slope is not adjacent to public right-of-way.
Other Easements	20 feet ²

Notes:

1. Lots less than one acre in size are not required to dedicate public utility easements along the side and rear lot lines.
2. Final easement width shall be determined by pipe width, required trench clearance and excavated side slopes not steeper than 2:1 horizontal to vertical.

9.3 Easement Location

Public utilities installed on private property shall be installed in public utility easements centered in private drive aisles. In no case shall public utilities be located under private parking spaces. Placement in

landscape areas is not desired, but may be acceptable on a case by case basis. Easements granted through decorative pavement or other unique surface materials shall note in the dedication documents the utility is not required to replace the specialty pavement.



Division 10 Street Lighting

**DIVISION 10
STREET LIGHTING**

10.1 General

The following design criteria shall govern the design of street lighting.

The Douglas County Master Plan (Chapter 10: Land Use Element) provides that urban communities utilize development standards related to typical urban uses, including street lighting. Chapter 10 also indicates that all areas outside of the urban areas are designated as rural, and that the development standards for rural areas include “limited street lighting for safety”.

The street lighting shall be the responsibility of the subdivider or developer who shall make all necessary arrangements for the installation of such lights as approved by the County. All street lighting within each construction phase shall be complete and operational prior to issuance of any certificate of occupancy.

These standards apply to lighting for public roads and road intersections. They do not apply to lighting of driveways, which would be considered during the development review process. (If lighting of a driveway is required, the lighting would be provided, owned and maintained by the developer at no cost to the County, outside of the County right-of-way.)

All street lights shall be metered. Street lighting systems shall be designed so that, to the extent possible, the number of meters needed to serve the lights is minimized.

10.2 Design Criteria

Street lighting in urban areas shall be consistent with urban development practices. Street lighting in rural areas shall be designed to provide limited street lighting for safety. The design engineer is responsible for designing street lighting in accordance with generally accepted engineering practices and standards, and meeting the appropriate standard of care in the design. References available to the design engineer include but are not limited to current editions of the AASHTO Roadway Lighting Design Guide, IESNA Roadway Lighting publication RP-8-00, NCHRP Report 612 Safe and Aesthetic Design of Urban Roadside Treatments, NCHRP Report 672 Roundabouts: An Informational Guide, IES publication DG-19-08 Design Guide for Roundabout Lighting, AASHTO Roadside Design Guide, and NCHRP Report 612 Safe and Aesthetic Design of Urban Roadside Treatments.

10.3 Street light Location

Street lights shall be located as far from the travelled way as is practicable.

A. Within urban service area boundaries:

1. A minimum of one street light shall be located at each residential local street intersection.
2. A minimum of one street light shall be located at each three-legged intersection (all classifications).
3. A minimum of one street light shall be located at the end of each cul-de-sac or permanent dead end street.
4. A minimum of two or more street lights shall be located at all other street intersections.
5. A minimum of one street light may be required at turning points.
6. Lighting of spot locations may be required when the driver is required to pass through a section of road with complex geometry or raised channelization.

B. In rural areas (outside of urban boundaries):

1. A minimum of one street light shall be required at a 3-legged intersection of an arterial and any other road.
2. A minimum of two street lights shall be required at a 4-legged intersection of an arterial and any other road.
3. A minimum of one street light shall be located at the intersection of two collector roads.
4. Lighting of spot locations may be required when the driver is required to pass through a section of road with complex geometry or raised channelization.

C. Roundabouts

A minimum of one street light shall be located on the approach to each crosswalk so that pedestrians in the crosswalk are front lit. (For a roundabout with four crosswalks, this results in a minimum requirement of eight street lights.)

10.4 Improvement Plans

Street lighting plans shall be submitted by the subdivider or developer to the County for review as part of the improvement plans. Such plans shall show the location of each light, type of pole and foundation, make, model, type and wattage of the luminaries, locations of meters, indicate which lights are served by each meter, and a statement that the street light illumination provides safety lighting adequate for the protection of the public.

10.5 Street Light Fixtures

A. Fixtures to be maintained by the County:

All street light fixtures to be maintained by the County shall be one of the following:

1. 250 watt high pressure sodium (HPS), or
2. BETA's LEDway streetlight (IP66), 90 LEDs, Type 2, Medium Distribution, or
3. GE's Evolve LED Cobrahead (R150), 157W, Type 3 Asymmetric wide-medium distribution, or
4. Other LED fixtures as may be approved by Public Works

B. Fixtures to be maintained by others:

1. The entity (i.e., Town, GID, etc.) responsible for maintenance of the street fixtures shall approve the fixtures prior to approval of the plans by the County.
2. Where the entity responsible for maintenance of the fixtures has not been clearly defined, the fixtures shall meet the criteria above for fixtures to be maintained by the County.

10.4 Safety Bases and Street Light Poles

Street lights shall be located as far from the traveled way as is practical. Street light foundations shall be constructed in accordance with the posted speed limits and available lateral clearance:

Minimum Pole Foundation Requirements

Lateral Clearance from front face of curb to face of pole (feet)	35 mph	40 mph – 45 mph
0 – 2 feet	No poles allowed	No poles allowed
2 feet – 8 feet	Breakaway/safety bases	Breakaway/safety bases
8 feet – 12 feet	No special requirement	Breakaway/safety bases
Greater than 12 feet	No special requirement	No special requirement

1. This table is based on the information provided in NCHRP Report 612, Safe and Aesthetic Design of Urban Roadside Treatments.
 2. For urban areas, a lateral clearance of 12’ from face of curb to face of pole is desirable and should be provided when practicable.
 3. For rural conditions, provide a minimum clearance of 10 from the edge of traveled way to the front face of pole, no special base requirement. For clearance of less than 10’ a breakaway/safety base is required.
- A. Street lights to be maintained by the County:
1. Where safety bases are required the street light poles shall be NDOT Type 7 or Type 14.
 2. Where safety bases are not required the street light poles shall be direct burial poles of the same type as are provided by NV Energy. Luminaries shall have a maximum height of 33’ measured from the road surface to the luminary tenon, unless otherwise approved by Public Works.
- B. Street lights to be maintained by others
1. The entity (i.e., Town, GID, etc.) responsible for maintenance of the street lights shall have the ability to specify the type of foundations and poles to be used.
 2. Where the entity responsible for maintenance of the street lights has not been clearly defined, the foundations and poles shall meet the criteria above for street lights to be maintained by the County.



Division 11 Inspection and Testing

**DIVISION 11
INSPECTION AND TESTING**

11.1 General

This Division presents the requirements and responsibilities of those parties involved in the inspection, testing, verification, and acceptance of improvements constructed within Douglas County and to ensure the consistent quality of such improvements.

The Division consists of three sections. Section One outlines the protocol for the inspection and testing of improvements that are designed and constructed due to private development. Section Two of this Division outlines the protocol for the inspection and testing of improvements that are being completed by a public agency. Section Three of this Division outlines the protocol for the inspection and testing for projects completed by a public utility company that operates under a franchise agreement with Douglas County or a private utility company (private water companies, natural gas, cable, telephone, etc.).

SECTION ONE:

This section applies to work completed due to private development within Douglas County. The County is the legal permitting agency for construction that occurs under Title 12, 18 or 20 of the Douglas County Code. After the permit is issued Douglas County has the option to retain or delegate authority (at the request for the Entity that will maintain the completed improvements) to inspect the construction of public improvements constructed by a private developer following this Division. If a delegation of inspection authority is assigned to a Town or GID, the protocols in this manual are valid only up to and including the preconstruction conference. The Town or GID shall handle inspections and testing as they see fit. The private developer of the project shall be considered the owner for the purposes of this section.

11.2 Responsibilities

11.2.1 Owner

The owner must:

1. Retain and be financially responsible for the services of an Engineer of Record.
2. Retain and be financially responsible for the services of a Quality Control Testing Firm (QC) which shall report to the Engineer of Record. The quantity and type of tests required shall be in accordance with Orange Book Section 336.
3. Make every reasonable effort to retain the QC and the Engineer of Record that were responsible for the preparation of the approved soils report and the approved improvement plans respectively.
4. Retain and be financially responsible for the services of a contractor, properly licensed by the State of Nevada, to perform the nature of the work required.
5. Be responsible to the County for the adequacy of design and completed work. Defective design, material, equipment, or workmanship, or unsatisfactory work which may be discovered before final acceptance, or within one (1) year thereafter, must be corrected immediately at the request of the Engineer of Record or County Engineer, without extra charge, notwithstanding that it may have been overlooked in previous inspections. The failure to ensure adequate oversight of inspection of the contractor's work shall not relieve the owner from the obligation to perform sound and reliable work.
6. Designate a representative with authority to act on behalf of the owner.

1 **11.2.2 Contractor**

2 The Contractor must:

- 3
- 4 1. Attend the preconstruction meeting. The contractor should provide a list of proposed shop
5 drawings and materials lists (if the shop drawings or materials are not in conformance with
6 the Orange Book) at this time, however alternate materials and methods are able to be
7 considered by the County Engineer at any time during construction. The contractor shall
8 discuss proposed construction methods and materials testing procedures and designate a
9 representative who has the authority to resolve issues during construction and who will be on-
10 site on a daily basis during construction.
- 11
- 12 2. The contractor shall not initiate any construction activity, including erosion control and
13 fencing until all utilities, Towns, and GIDs have completed field locate markings or prior to
14 the preconstruction meeting.
- 15
- 16 3. Notify the County Inspector of the date and estimated time that work on the following items
17 is expected to begin:
- 18 a. Grading, excavation, and fill operations.
- 19
- 20 b. Placement and testing of sewer lines, water lines, and storm drain lines.
- 21
- 22 c. Backfilling of water lines, sewer lines, drainage lines or appurtenances.
- 23
- 24 d. Placing of reinforcing steel, forms and falsework for concrete structures.
- 25
- 26 e. Placing the concrete for curbs, gutters, sidewalks, alleys, valley gutters, headwalls,
27 or structures.
- 28
- 29 f. Placing of base course or subbase material.
- 30
- 31 g. Placing asphalt concrete or Portland cement concrete pavement.
- 32
- 33 h. Sealing asphalt concrete or Portland cement concrete pavement.
- 34
- 35 1. Installation and testing of landscape irrigation.
- 36
- 37 j. Drilling and construction of municipal wells and water storage tanks.
- 38
- 39 The required notification must be given not less than one (1) working day in advance and, if
40 subsequent conditions cause a delay to the start of work, the contractor shall notify the
41 County Inspector of the delay as soon as possible (*See*, Section 11.3, Inspection
42 Requirements, for additional information). It is understood that conditions beyond the control
43 of and due to no fault of contractor may require a change in the day's schedule.
- 44
- 45 4. Inspect all workmanship and materials in accordance with this manual, the Orange Book and
46 the approved contract documents. No work or materials will be accepted by the County
47 without all required inspection and testing having been completed.
- 48
- 49 5. Changes to the approved plans:
- 50
- 51 A) For work on private property the contractor shall notify the Engineer of Record, of
52 proposed changes to the approved improvement drawings. The Engineer of Record shall
53 determine the appropriate course of action. For items on private property which are
54 regulated under County Code the Engineer of Record should notify the County Engineer

1 of the proposed change as soon as practical and understands any direction to the
2 contractor without consulting the County Engineer shall be considered “at risk.”
3

4 B) For work on items the public will maintain (items within a Right of Way or Public
5 Easement), the contractor shall immediately notify the Engineer of Record of the
6 proposed changes from the approved improvement drawings. If the proposed change
7 does not meet minimum County Standards, the Engineer of Record shall notify the
8 County Engineer of the proposed change. Such a change may require submittal of
9 revised plans if required by the County Engineer. The County Engineer will forward the
10 proposed changes to any affected Town, GID, or private utility for review. The County
11 will not be liable for delays caused by the review and approval of such changes. The
12 County Inspector shall be made aware of any field changes directed by the Engineer of
13 Record as soon as possible. If it is later determined that the direction provided by the
14 Engineer does not meet minimum County standards an alternative solution may be
15 required.
16

- 17 6. Provide accessibility and exposure of all construction work subject to inspection (See Section
18 11.3) until inspected by the County Inspector and the QC. The County shall not be liable for
19 expenses entailed in the removal or replacement of material required to allow inspections to
20 occur.
21
22 7. Notify the County Inspector at least one (1) working day in advance of initiating construction
23 or resuming construction after unscheduled interruptions.
24
25 8. Be responsible for construction site safety and adherence to all safety regulations, including
26 Occupational Safety and Health Administration (OSHA) Standards.
27

28 11.2.3 County Engineer

29 The County Engineer or a designated representative must:
30

- 31 1. Assign a primary contact (County Inspector) to the contractor who shall serve as the County’s
32 representative during construction of improvements. For projects within the limits of a GID
33 or Town, please refer to Section 11.4, Delegation of Inspection Authority, for additional
34 information.
35
36 2. Attend the preconstruction conference and provide meeting minutes to all attendees within a
37 week after the meeting
38
39 3. Provide the contractor a more detailed list of work that requires notification per 11.2.2.3 at
40 the time of permit issuance.
41
42 4. Keep a daily report of construction activities, including pertinent conversations with the
43 contractor, Town, GID, Utility Purveyors, Engineer of Record, and Testing Firms.
44
45 5. Review the daily inspection/testing reports submitted by the QC on a weekly basis.
46
47 6. Provide written notification to the owner, contractor, and Engineer of Record when materials
48 or workmanship that do not meet County standards have been constructed and have not been
49 satisfactorily corrected by the contractor within one week of verbal notification to the
50 contractor. The written notification shall be supported by field reports and/or test results.
51
52 7. Conduct a semi-final inspection upon substantial completion of the work, and a final
53 inspection upon final completion of the work, and prepare a list of items that are deficient and
54 need to be corrected prior to acceptance of the improvements by the County.
55

1 **11.2.4 Engineer of Record**

2 The Engineer of Record must:

- 3
- 4 1. Furnish plans and, as required (if materials or details differ from county standards),
5 specifications on behalf of the owner to the County and any other Entity which will be
6 accepting maintenance of infrastructure at the completion of the project for permit review and
7 approval.
- 8
- 9 2. Prior to the preconstruction conference, submit the qualifications of the QC, any field
10 inspection personnel, and testing technician personnel for the project to the County Engineer
11 for review. Personnel qualifications shall meet the minimum qualifications specified in this
12 manual.
- 13
- 14 3. Initiate a preconstruction conference prior to the start of construction. Representatives
15 inclusive of all affected agencies shall receive notice of the meeting both in writing and by
16 phone. The notice shall be issued as soon as possible, but in no case later than two business
17 days prior to the meeting unless agreed upon by all participants.
- 18
- 19 4. During construction, the Engineer of Record shall respond to contractor and County Requests
20 For Information (RFI). If deviations from the approved plans are necessary under Section
21 11.2.2.5, the Engineer of Record shall prepare revised plan sheets and submit them to the
22 County for review and approval.
- 23
- 24 5. If finished work is found to be defective by the County due to materials, improper design,
25 construction means and methods, or negligence, the Engineer of Record may assist the
26 contractor in providing a solution that does not require complete removal and replacement of
27 the work. Any considered proposal must have the seal of the engineer and must be reviewed
28 by the contractor prior to review by the County. The County Engineer will have the final
29 authority to approve or deny the Engineer of Record's recommendations.
- 30
- 31 6. Provide to the County, upon completion of improvements, a letter verifying the improvements
32 were constructed in compliance with this manual, approved improvement plans, and County
33 standards. Provide a copy of the record drawings in PDF format and DWG format to the
34 County on a compact disk or other electronic medium acceptable to the County. The final
35 completion and acceptance of all such improvements, including recommendations of release
36 and return of security (if any), shall be subject to the approval of the County Engineer.
37 Sufficient copies shall be provided to the County so that the County may provide any Town,
38 GID, or Utility Purveyor with a copy of the record drawings.
- 39

40 **11.2.5 Quality Control Testing Firm**

41 The Quality Control Testing Firm must:

- 42
- 43 1. Provide the Engineer of Record a list of materials testing technicians that will be assigned to
44 the project.
- 45
- 46 2. Attend the preconstruction conference.
- 47
- 48 3. Notify the contractor and County Inspector of the preliminary result of the material tests and
49 provide authorization for the contractor to continue to the next step of construction.
- 50
- 51 4. Provide chronological copies of inspection and test reports, at the end of each week, for the
52 previous week's inspections and tests for work completed within the Right of Way or in a
53 public utility easement. These copies may be electronic or bound paper copies. The County
54 shall keep one copy and make the other copies available to the Town, GID, or other utility

1 company that requests a copy. The number of weekly copies shall be determined at the
2 preconstruction meeting.

3
4 For work on private property, the County requires the results of the materials tests at the end
5 of the project. The results of these tests are not for review, but to include in the archiving of
6 the information for a permanent public record
7

8 **11.3 Inspection Requirements**

9 10 **11.3.1 General**

11 For the purpose of implementing the requirements of this manual, inspection shall mean the County Inspector
12 who shall be present to observe the operations of the contractor during scheduled inspections or at other times
13 as the County Inspector deems necessary. The County is required to have an inspector onsite during contractor
14 scheduled inspections. County staff may assist in the inspection, as directed by the County Engineer, to ensure
15 the contractor's schedule is met. If the County is unable to be present onsite when requested by the contractor,
16 certain inspections may be waived by the County Inspector orally to not delay the contractor with the project
17 schedule. Written notification of this waived inspection will be sent to the contractor via email or post for the
18 contractor's records.
19

20 **11.3.2 Preconstruction.**

21 If a Town or GID requests the Delegation of Inspection Authority the following protocol will only apply to
22 onsite improvements that will not be maintained by the Town or GID. The Town or GID may establish their
23 own protocol for the testing and inspection for items they will own and maintain within the ROW. (See Section
24 11.4)
25

- 26 1. Upon approval of the plans submitted by the Engineer of Record, the County will notify the
27 owner and the Engineer of Record that a permit is ready to be issued.
28
- 29 2. The approved plans and inspection notification list may be picked up by the Engineer of
30 Record, Contractor, or Owner after payment of fees, the permit will not be issued until the
31 preconstruction conference has occurred or waived by the County Engineer (See Item 5
32 below).
33
- 34 3. A preconstruction conference must be scheduled by the Engineer of Record as required under
35 Section 11.2.4.3.
36
- 37 4. Upon completion of the preconstruction conference the County Engineer will provide the
38 permit to the contractor.
39
- 40 5. The contractor may request to forgo a preconstruction conference if they feel the conference
41 is not necessary for the project. This request will be granted with concurrence from all
42 affected GIDs, Towns, utility companies, and the County Engineer. Written permission to
43 forgo the preconstruction conference will be included with the issued permit.
44

45 **11.3.3 Construction**

- 46
47 1. The County Inspector must, at a minimum, be notified the day before work will begin on the
48 following items that will be owned or maintained by the public In order to clarify the specific
49 items that require this notification, a list shall be provided to the contractor at the time of plan
50 approval.
51

52 The list below is not intended to be a required construction sequence for improvements.
53 Work may be concurrent on numerous items. The means and methods of construction are left
54 to the contractor unless specifically called out in the Orange Book. The means and methods
55 selected for construction must allow for testing per Section 336 of the Orange Book

- 1
 - 2
 - 3
 - 4
 - 5
 - 6
 - 7
 - 8
 - 9
 - 10
 - 11
 - 12
 - 13
 - 14
 - 15
 - 16
 - 17
 - 18
 - 19
 - 20
 - 21
 - 22
 - 23
 - 24
 - 25
 - 26
 - 27
 - 28
 - 29
 - 30
 - 31
 - 32
 - 33
 - 34
 - 35
 - 36
 - 37
 - 38
 - 39
 - 40
 - 41
 - 42
 - 43
 - 44
 - 45
 - 46
 - 47
 - 48
 - 49
 - 50
 - 51
 - 52
 - 53
 - 54
 - 55
- A. Curb, Gutter, and Sidewalk
 - I. Subgrade
 - II. Base
 - III. Forms
 - IV. Concrete Placement
 - V. Final Inspection
 - B. Pavement
 - I. Subgrade
 - II. Base
 - III. Paving
 - a. weather conditions
 - b. concrete curbing has cured as required by Orange Book
 - c. base material undamaged and free from moisture
 - d. proper equipment onsite
 - e. tack coat material and installation meets specifications
 - f. supplied asphalt meet specifications for material and temperature
 - g. asphalt installed in proper lifts and with rolling procedures
 - IV. Manhole, Valve, and Monument Adjustments
 - V. Final Inspection
 - C. Water
 - I. Trench Excavation
 - II. Bedding
 - III. Pipe
 - IV. Bedding Backfill
 - V. Trench Backfill
 - VI. Final Inspection and Testing
 - D. Sewer (Sanitary and Storm)
 - I. Trench Excavation
 - II. Bedding
 - III. Pipe
 - IV. Bedding Backfill
 - V. Manholes
 - VI. Trench Backfill
 - VII. Rip-Rap/Detention Basin Inspections (Storm Sewer)
 - VIII. Final Inspection and Testing.
 - E. Landscaping (Within Right of Way Only)
 - I. Irrigation Conduit
 - II. Controls
 - III. Plant Condition
2. Contractor and Inspector Coordination:
- A) The contractor shall arrange inspections by contacting the County Inspector the day before the work will begin, either in person, email or by phone. Required inspections are those where work is being completed within a Right of Way or Public Utility Easement. The contractor shall leave a message if the contact is over the phone requesting either a morning or afternoon inspection. The County Inspector shall coordinate the next morning with the contractor for the approximate time the inspection will be necessary. The contractor shall also state the approximate limits, by station, of the inspection.

- 1
- 2 B) For work on private property that will not be the maintenance responsibility of the public the
- 3 County will make unannounced site inspections as it deems necessary, but the contractor shall
- 4 not be required to coordinate these inspections.
- 5
- 6 3. If the contractor has proceeded to the next phase of construction without notifying the County
- 7 Inspector that the work was to take place the County Engineer may issue a Stop Work Order. The
- 8 missed inspection shall be corrected by unearthing the previous work and allowing the inspection to be
- 9 completed.
- 10
- 11 4. If material test results are not being provided by the QC or the County has reason to question the
- 12 results of the test, the County may hire a third party QC. If the results of the test from the 3rd party QC
- 13 are different than the original test results with respect to pass/fail the County shall be justified in
- 14 billing the owner for the additional test.
- 15
- 16 5. Plans approved by the Douglas County Community Development Department must be readily
- 17 available on site at all times. All plan sheets must have an "SIP Approval" stamp. If approved plans
- 18 are not on site, the contractor may be issued a Stop Work Order. Work shall not commence until the
- 19 approved plans are on site. Approved plans shall include all plan sheets that have been revised after
- 20 initial county approval.
- 21
- 22 6. For underground utility work to be maintained by a GID (GID owned water, MGSD, TDSD, etc.)
- 23 where the GID does not also maintain the road, the inspection and authority of the GID extends to pipe
- 24 zone (e.g. 1-foot above the top of pipe). The trench and road section of these improvements shall be
- 25 under the inspection of the entity that is responsible for the maintenance of the roadway (following the
- 26 Delegation of Inspection Authority).
- 27

28 **11.4 Delegation of Inspection Authority**

29 **11.4.1 General**

30 The County recognizes that public agencies such as a General Improvement District (GID) or Town ("Entity"

31 or collectively, "Entities") may not own a public right-of-way impacted by construction but may maintain the

32 improvements within the right-of-way. Since the Entities may be responsible for maintaining these

33 improvements, the County believes the Entities should have the opportunity to test and inspect the facilities

34 they will be responsible for maintaining. A delegation of inspection authority will be granted at the request of

35 an Entity on a project-by-project basis. (Following item 9 below). It is also understood that the County is the

36 permitting agency and has the ultimate responsibility to ensure that all testing and inspection standards are met.

37

38

39

40 **11.4.2 Delegation of Inspection Authority Procedure**

- 41
- 42 1. Site Improvement Permit (SIP) applications that are submitted for review for projects that are located
- 43 within the boundaries of an Entity shall be forwarded to the Entity for review.
- 44
- 45 2. The Entity shall fill out and return the "Delegation of Inspection Authority" form found at the end of
- 46 this division to the County within ten (10) working days from the date the plans were submitted to the
- 47 County. In order to be eligible to assume this inspection responsibility, the Entity must have a
- 48 registered professional engineer on staff or under contract to respond to the contractor or inspector
- 49 "request for information" during construction. The Entity must also identify and provide the phone
- 50 number for the individual responsible for conducting any inspection to the County.
- 51
- 52 3. If the Entity accepts the responsibility for conducting inspections, the County agrees that it will not
- 53 collect any testing or inspection fees (for the items that will be inspected by the entity) prior to issuing
- 54 any permit. The collection of any testing and inspection fees shall be the responsibility of the Entity.
- 55

- 1 4. The County will transfer the inspection and testing authority to the Entity at the preconstruction
2 conference.
- 3
- 4 5. If the Entity determines that deviations from the approved plans are necessary for any reason, the
5 Engineer of Record shall prepare revised plan sheets and submit them to the County for review and
6 approval. The County will provide a set of plans to the Entity to review and approve.
7
- 8 6. The County Inspector shall visit the site to conduct an inspection per the approved plans but will not
9 provide direction directly to the contractor unless the direction involves public life/safety issues. All
10 communication from the County Inspector to the contractor shall be through the inspector designated
11 by the Entity.
12
- 13 7. The Entity shall provide the County with weekly material testing results.
- 14
- 15 8. The County will be given the opportunity to attend the final inspection with the Entity to verify that
16 the project was constructed in accordance with the approved plans. During final inspection, the
17 County may add items to the final punch list. Additional items unrelated to the punch list items may
18 not be added after final inspection unless the items affect the health and safety of the public.
19
- 20 9. The Entity will provide the County with a set of digital “Record Drawings” prepared by the Engineer
21 of Record at the completion of the project.
22
- 23 10. If the Entity fails to fulfill its responsibilities or to otherwise coordinate with the County (for example;
24 provide materials test results, coordinate or allow for final inspection of the project, or provide “as
25 built” plans), the County may determine that the Entity is unable to perform testing and inspection
26 duties and may revoke that authority for future projects.
27

28 **11.5 Testing Services**

30 **11.5.1 General**

31 All Materials Testing must be performed in accordance with the requirements contained in Orange Book
32 336.00-1
33

34 **11.5.2 Testing Firm**

36 **11.5.2.1 Laboratory**

37
38 The testing firm shall be responsible for the laboratory testing of soil, concrete, asphalt and any other tests as
39 required by the Orange Book. The testing firm must have suitable test equipment and laboratory facilities for
40 the storing, preparation and testing of samples. The firm must have the capability of performing all laboratory
41 testing associated with its intended functions according to governing procedures and shall have the facilities
42 and equipment required for all laboratory testing it performs. If equipment or expertise in the performance of a
43 specialized test is not available in-house, then the services of a subconsultant or its equipment may be utilized.
44

45 Testing Laboratories shall be accredited by American Association of State Highway and Transportation
46 Officials (AASHTO) Materials Reference Laboratory (AMRL). For concrete testing only, the laboratory may
47 be accredited by the Cement and Concrete Reference Laboratory (CCRL). If a laboratory obtains an
48 accreditation they believe to be equivalent to the two listed above, then the laboratory may submit its
49 accreditation information to the County Engineer for review and approval. This equivalency review must be
50 completed prior to the issuance of the NTP.
51

52 **11.5.2.2 Individuals**

53

1 Individuals who perform field testing and sampling shall have the appropriate qualification from the Nevada
2 Alliance for Quality Transportation Construction or a minimum of 5 years testing experience. For concrete
3 testing an ACI Grade 1 Technician certification is required.

4 5 **SECTION TWO**

6 7 **11.6 Capital Projects Completed by a Public Agency**

8 9 **11.6.1.1 General**

10 This section of the manual shall apply to any construction performed by a Town, GID, State Agency, Federal
11 Agency, another County Department (e.g., Parks & Recreation or Public Works), or a public utility company
12 (collectively, "Entity") that does not operate under a franchise agreement with Douglas County. This section
13 applies only to the issuance of a SIP or encroachment permit and does not impact those activities within the
14 jurisdiction of the Building Division. Maintenance work completed by a public agency is outside of the scope
15 of this division.

16 17 **11.6.1.2 Inspection**

- 18
19 1. A permit for work within a public right-of-way shall be issued in accordance with the Douglas County
20 Code. Regardless of code, permits submitted for maintenance work shall be issued at no cost to the
21 Entity.
- 22
23 2. A preconstruction conference must be scheduled by the department or Entity as required under Section
24 11.3.2. For less complex projects the contractor may request to forgo a preconstruction conference.
25 With concurrence from all affected GIDs, Towns, utility companies, and the County Engineer, written
26 permission to forgo the preconstruction conference will be granted.
- 27
28 3. If the completed improvements will be maintained by a public Entity, or if the improvements are being
29 completed by a County department other than Community Development, the procedures outlined in
30 Section 11.3 for inspection may be modified as follows:
 - 31
32 a. The Entity may hire a third party inspector to oversee the construction of the project. The
33 selected third party inspector will be responsible for arranging all testing and inspection
34 duties related to the project.
 - 35
36 b. The County Inspector shall have the authority to visit the construction site but will only
37 provide direction to the contractor through the third party inspector, unless the direction
38 corrects items that pose a threat to public health or safety.
- 39
40 4. In order to receive a Notice of Completion, the County must receive a copy of the record drawings in
41 an electronic format on a compact disk or other electronic medium acceptable to the County. Bound
42 chronological copy of inspection and test reports must be provided to the County. Although the
43 constructed facilities will not be maintained by the County, the County must have a permanent record
44 of what has been constructed within the public right-of-way.

45 46 **SECTION THREE**

47 48 **11.7 Public Utility Companies that Operate Under a Franchise Agreement or Private Utilities**

49
50 The following section applies only to construction by a public utility company that operates under a franchise
51 agreement with Douglas County or a private utility company this includes private water companies, cable,
52 telephone, gas, power, etc. that secure an encroachment permit from Douglas County. Projects that require a
53 site improvement or building permit shall be handled under Section Two of this Division. If the work to be
54 completed within the boundary of a Town or GID a delegation of inspection authority will be granted at the
55 request of an Entity on a project-by-project basis in accordance with Section 11.4. It is also understood that the

1 County is the permitting agency and has the ultimate responsibility to ensure that all testing and inspection
2 standards are met. If the work is completed within a County maintained road or within a GID maintained road
3 where the inspection authority is not requested by the entity the following protocol shall be followed:
4

- 5 1. A permit shall be applied for in accordance with Douglas County Code. The majority of work
6 requested by a private utility shall be completed under an encroachment permit.
7
- 8 2. A preconstruction conference must be scheduled by the utility company or contractor as required
9 under Section 11.3.2. For less complex projects the contractor may request to forgo a preconstruction
10 conference. With concurrence from all affected GIDs, Towns, utility companies, and the County
11 Engineer, written permission to forgo the preconstruction conference will be granted.
12
- 13 3. Work shall be completed by a properly licensed contractor or by in house utility crews following
14 Nevada Revised Statues Chapter 624.
15
- 16 4. The utility company shall arrange all inspection and testing.
17
 - 18 a. For work within the Right of Way, provide two bound chronological copies of inspection and
19 test reports or an electronic copy, at the end of each week for the previous week's inspections
20 and tests. The County shall keep one copy and provide the second copy to the Town or GID
21 where the work has taken place.
22
 - 23 b. For work on private property, copies of the materials testing are not required.
24
- 25 5. The County Inspector will visit the site. Standards and details shall follow Douglas County Details for
26 trench and pavement replacement. Utility standards and details shall be used for work within the pipe
27 zone and all appurtenances. Items which may affect the roadway are under the jurisdiction of the
28 entity that owns the Right-of-Way.
29

30 If the delegation of inspection authority is accepted the Entity may deviate from the above written protocol as it
31 sees fit, but at a minimum the entity shall:
32

- 33 1. Provide the County with weekly material testing results.
34
- 35 2. Provide the County with the opportunity to attend the final inspection to verify that the project was
36 constructed in accordance with the approved plans. The County may add items to the final punch list
37 for the contractor to complete during the final inspection. Additional items unrelated to the punch list
38 items may not be added after final inspection unless the items affect the health and safety of the public.
39

40 If the Entity fails to fulfill its responsibilities or to otherwise coordinate with the County (for example, it does
41 provide materials test results or coordinate or allow for final inspection of the project,) the County may
42 determine that the Entity is unable to perform testing and inspection duties and may revoke that authority for
43 future projects.
44
45

Delegation of Inspection Authority

Douglas County agrees to delegate the authority for construction inspection and testing to

_____ (“Entity”) for the project known as _____ located at

_____ (APN) _____. The
(physical address)

individual responsible for performing all required inspections is _____ and can be

reached at _____. _____ is the Nevada Registered Professional
(phone number)

Engineer assigned to the project and has obtained all necessary Insurance coverage provided

through _____ to work on public works construction projects.
(firm name)

Entity agrees to comply with the requirements contained in the Douglas County Code and Design Standards Manual and will involve Douglas County in the construction process as required by those Design Standards. The Entity further agrees to indemnify and hold Douglas County harmless for any claims arising from or related to the construction of the Project, including any claim that a required inspection was not properly performed.

DATED this _____ day of _____, 20____.

(Entity)

(Name and Position)



Appendix A

Street Improvement Details

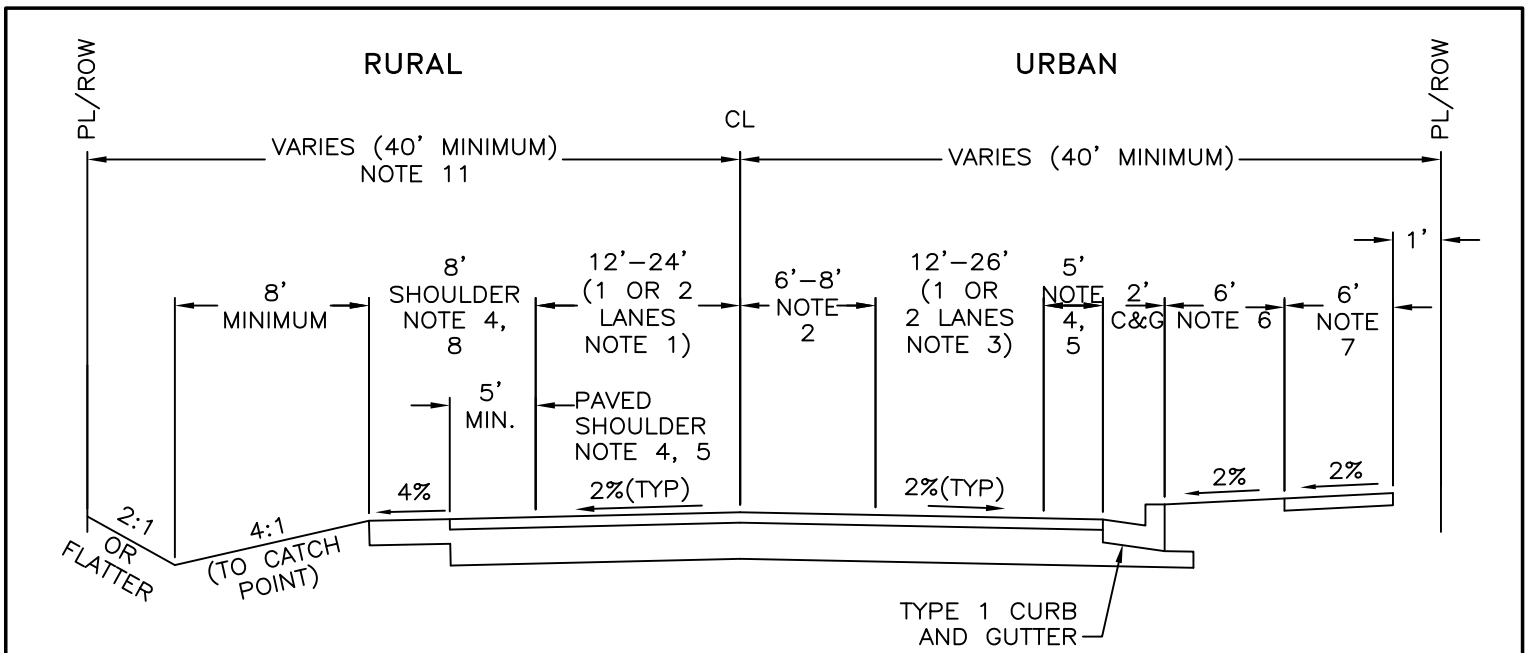

NOTES:

1. NUMBER OF LANES DETERMINED BY TRANSPORTATION ELEMENT OF THE DOUGLAS COUNTY MASTER PLAN.
2. USE 8 FEET AND A RAISED PCC MEDIAN CURB (SEE DETAIL A05-B) ON 4 LANE URBAN SECTIONS WHEN TURN LANE IS REQUIRED. USE 6 FEET FOR RURAL SECTION WHEN TURN LANE IS REQUIRED.
3. THE OUTSIDE LANE WIDTH SHALL BE 14 FEET FOR URBAN SECTIONS WHEN NO BIKE LANE IS REQUIRED. OUTSIDE LANE MAY BE 12 FEET FOR URBAN SECTIONS WHEN BIKE LANE IS PROVIDED. PARKING SHALL NOT BE ALLOWED ON STREET.
4. BIKE LANES SHALL BE PROVIDED IN CONFORMANCE WITH THE DOUGLAS COUNTY COMPREHENSIVE TRAIL PLAN. BIKE LANES IN RURAL AREAS SHALL BE 5 FEET WIDE AND CONSTRUCTED WITH THE SAME STRUCTURAL SECTION AS THE ROADWAY. WHERE THE BIKE LANE IS ADJACENT TO CURB AND GUTTER, THE BIKE LANE SHALL HAVE A MINIMUM 4 FOOT WIDTH MEASURED FROM THE TRAFFIC LANE TO THE LONGITUDINAL JOINT BETWEEN THE GUTTER PAN AND ROADWAY SURFACE.
5. BIKE LANES AND BIKE ROUTES SHALL BE SIGNED AND STRIPED IN CONFORMANCE WITH THE AASHTO "GUIDE FOR THE DEVELOPMENT OF BICYCLE CONTROL FACILITIES" AND THE FHWA "MANUAL ON UNIFORM TRAFFIC CONTROL DEVICES."
6. 6 FOOT MINIMUM LANDSCAPE STRIP.
7. SIDEWALKS SHALL HAVE A MINIMUM WIDTH OF 6 FEET.
8. PAVED SHOULDERS SHALL HAVE THE SAME STRUCTURAL SECTION AS THE ROADWAY. AGGREGATE SHOULDERS SHALL HAVE A MINIMUM OF 6 INCHES OF COMPACTED AGGREGATE BASE.
9. STRUCTURAL SECTION TO BE DETERMINED BY ENGINEERING DESIGN, BUT IN NO CASE SHALL THE ASPHALT CONCRETE BE LESS THAN 4 INCHES THICK AND THE AGGREGATE BASE LESS THAN 8 INCHES THICK.
10. TYPE 3 PLANTMIX BITUMINOUS PAVEMENT WITH PG 64-28 NV SHALL BE USED ON THE TOP PAVEMENT LIFT, MINIMUM THICKNESS 2-INCHES. TYPE 2 OR TYPE 3 PLANTMIX BITUMINOUS PAVEMENT WITH PG 64-28 NV SHALL BE USED ON LOWER PAVEMENT LIFTS, MINIMUM THICKNESS 2-INCHES.
11. PERMANENT SLOPE EASEMENTS MAY BE REQUIRED TO ACCOMODATE CONSTRUCTION OF THE ROADWAY AND DRAINAGE FACILITIES
12. STRIPING SHALL BE TYPE II WATERBORNE PAINT OR EPOXY PAINT. WATERBOURNE PAINT SHALL BE APPLIED IN TWO COATS, EACH HAVING A MINIMUM WET THICKNESS OF 25 MILS AND A MINIMUM DRY THICKNESS OF 15 MILS MEASURED WITHOUT GLASS BEADS. BOTH COATS SHALL INCLUDE GLASS BEADS AT THE RATE OF 9 LBS/GALLON. EPOXY BASED PAINT SHALL BE APPLIED IN A SINGLE COAT HAVING A MINIMUM DRY THICKNESS OF 20 MILS MEASURED WITHOUT GLASS BEADS. THE EPOXY PAINT SHALL INCLUDE GLASS BEADS AT THE RATE OF 18 LBS/GALLON.

NO.	REVISION	DATE	STANDARD DETAIL FOR PUBLIC WORKS CONSTRUCTION	SECTION: DOUGLAS COUNTY
			<h1>ARTERIAL/COLLECTOR TYPICAL ROAD SECTION</h1>	DATE: DEC. 2018
				DWG: A01

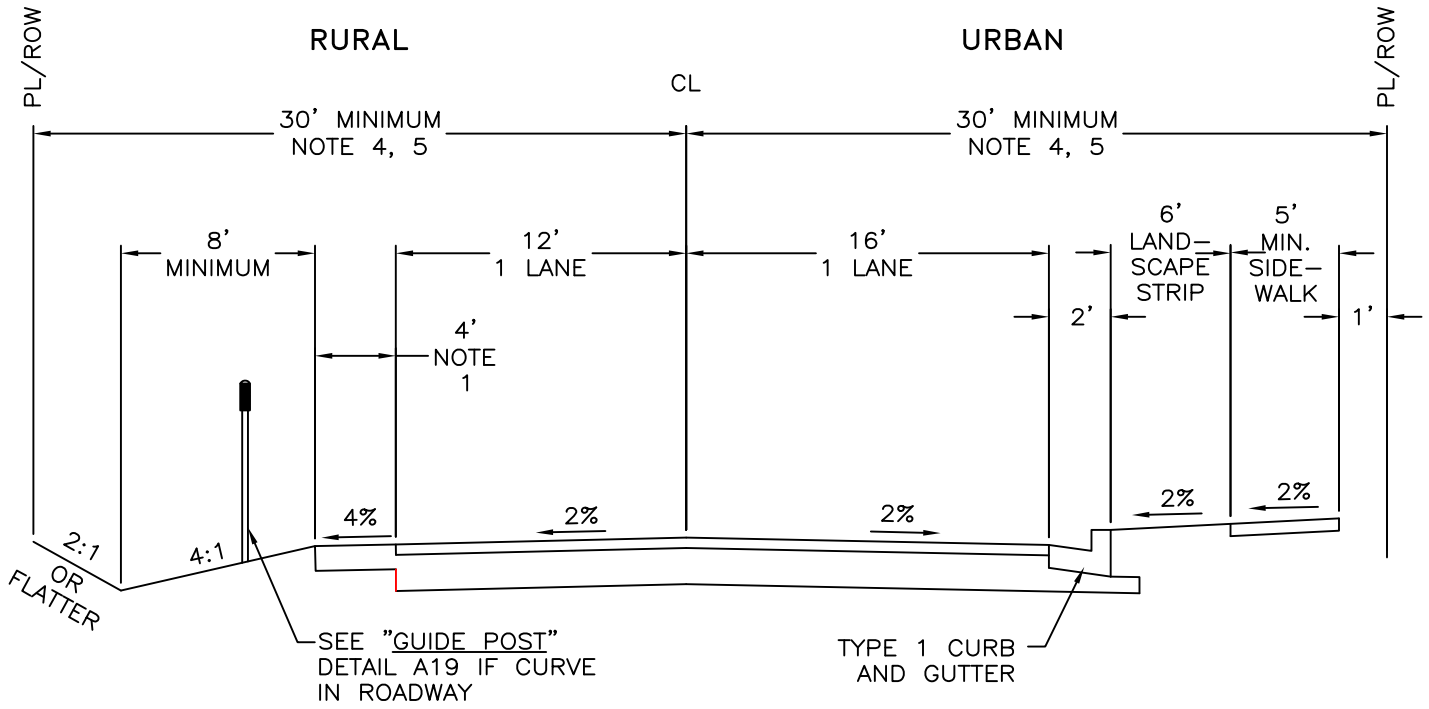

LOCAL ROAD SECTION

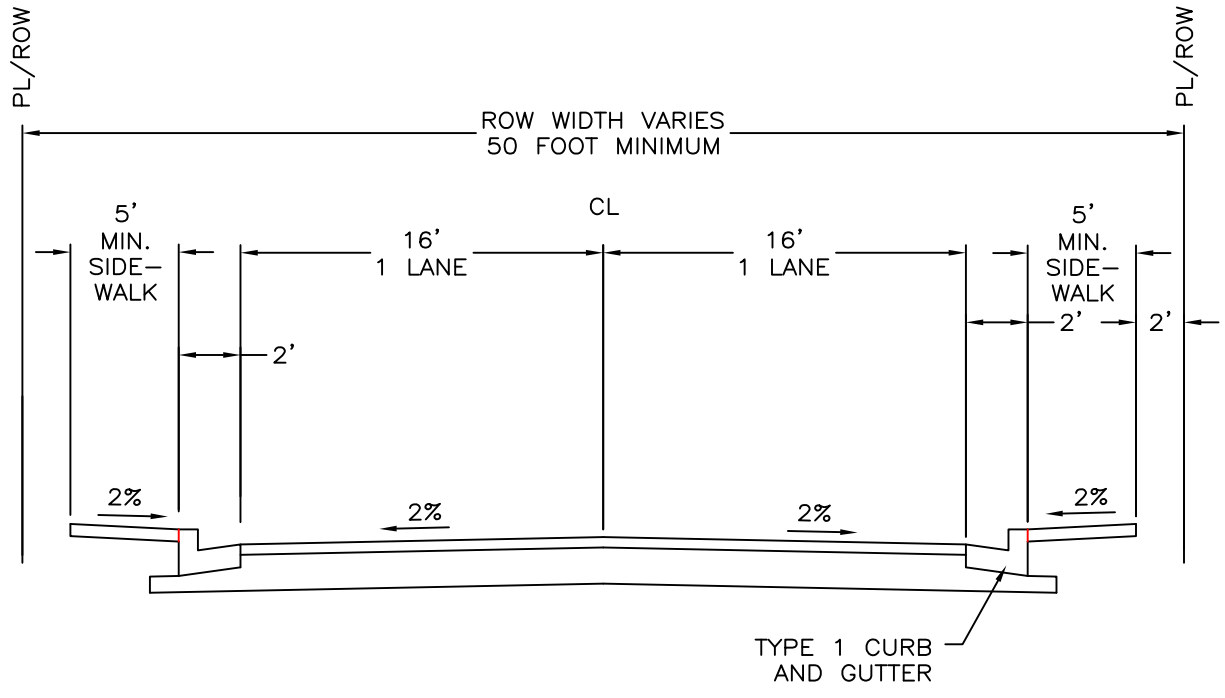

URBAN RESIDENTIAL LOCAL ROAD SECTION

NO.	REVISION	DATE	STANDARD DETAIL FOR PUBLIC WORKS CONSTRUCTION	SECTION: DOUGLAS COUNTY
			LOCAL ROAD SECTION	DATE: DEC 2018
				DWG: A02

NOTES:

1. AGGREGATE SHOULDERS SHALL HAVE A MINIMUM OF 6 INCHES OF COMPACTED AGGREGATE BASE.
2. STRUCTURAL SECTION TO BE DETERMINED BY ENGINEERING DESIGN, BUT IN NO CASE SHALL THE ASPHALT CONCRETE BE LESS THAN 3 INCHES THICK AND THE COMPACTED AGGREGATE BASE LESS THAN 6 INCHES THICK.
3. FLEXIBLE PAVEMENT SECTION SHALL CONSIST OF TYPE 3 BITUMINOUS PLANTMIX PAVEMENT OVER TYPE 2 BITUMINOUS PLANTMIX PAVEMENT (PER ORANGE BOOK SECTION 200.02). THE TYPE 3 SURFACE COURSE SHALL BE A MINIMUM THICKNESS OF 2-INCHES. THE TYPE 2 BASE COURSE SHALL BE AS THICK AS REQUIRED, BUT NO INDIVIDUAL LIFT SHALL BE GREATER THAN 3-INCHES COMPACTED. IF THE TOTAL THICKNESS OF THE STRUCTURAL SECTION IS 3-INCHES OR LESS, THE ENTIRE SECTION SHALL BE TYPE 3 BITUMINOUS PLANTMIX PAVEMENT. INSTALLATION SHALL BE PER ORANGE BOOK SECTION 320.
4. ALL ASPHALT CEMENT SHALL BE PG 64-28 NV PER ORANGE BOOK SECTION 201.
5. THE URBAN RESIDENTIAL LOCAL ROAD SECTION MAY BE SUBSTITUTED FOR THE LOCAL ROAD SECTION ABOVE DEPENDENT ON COUNTY, GENERAL IMPROVEMENT DISTRICT OR TOWNS' APPROVAL. A MINIMUM OF ONE FRONT YARD TREE SHALL BE PLANTED A MINIMUM OF 5' BUT NO GREATER THAN 8' FROM BACK OF SIDEWALK.
6. MONOLITHIC POUR CANNOT OCCUR ON THE RESIDENTIAL LOCAL ROAD SECTION WHEN SIDEWALK IS OUTSIDE OF RIGHT-OF-WAY OR REQUIRED TO BE MAINTAINED BY PRIVATE PROPERTY OWNER.
7. STRIPING SHALL BE TYPE II WATERBORNE PAINT OR EPOXY PAINT. WATERBOURNE PAINT SHALL BE APPLIED IN TWO COATS, EACH HAVING A MINIMUM WET THICKNESS OF 25 MILS AND A MINIMUM DRY THICKNESS OF 15 MILS MEASURED WITHOUT GLASS BEADS. BOTH COATS SHALL INCLUDE GLASS BEADS AT THE RATE OF 9 LBS/GALLON. EPOXY BASED PAINT SHALL BE APPLIED IN A SINGLE COAT HAVING A MINIMUM DRY THICKNESS OF 20 MILS MEASURED WITHOUT GLASS BEADS. THE EPOXY PAINT SHALL INCLUDE GLASS BEADS AT THE RATE OF 18 LBS/GALLON.

NO.	REVISION	DATE	STANDARD DETAIL FOR PUBLIC WORKS CONSTRUCTION	SECTION: DOUGLAS COUNTY
			LOCAL ROAD SECTION	DATE: DEC 2018
				DWG: A02

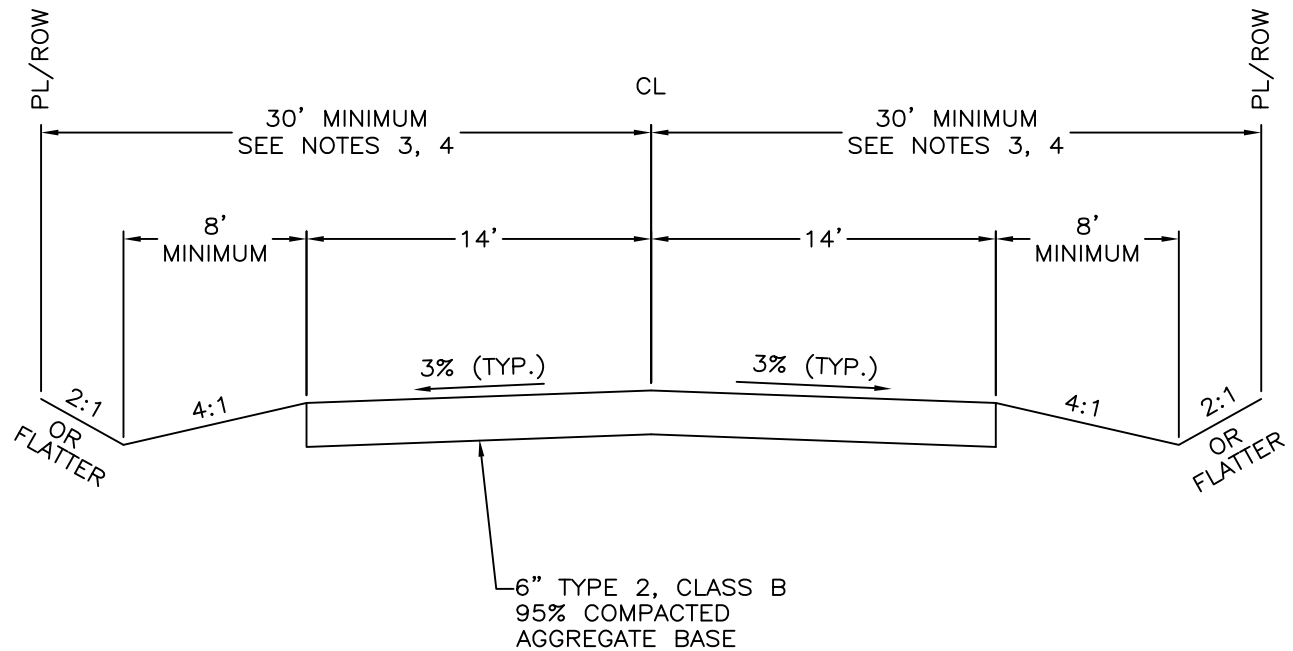

NOTES:

1. UNPAVED ROAD SECTION ALLOWED ONLY BY APPROVED VARIANCE OR PARCEL MAP WAIVER (SEE DCC 20.712.040).
2. STRUCTURAL SECTION TO BE DETERMINED BY ENGINEERING DESIGN, BUT IN NO CASE SHALL THE AGGREGATE BASE BE LESS THAN 6 INCHES THICK.
3. SITE SPECIFIC TRAFFIC DATA OR PROJECTIONS SHALL BE USED TO DETERMINE THE STRUCTURAL SECTION, BUT ALL STRUCTURAL SECTIONS MUST SUPPORT A TANDEM LOAD OF 25 TONS.
4. ROADS PROPOSED IN SPECIAL FLOOD HAZARD AREAS SHALL COMPLY WITH CHAPTER 20.50 OF TITLE 20.

NO.	REVISION	DATE	STANDARD DETAIL FOR PUBLIC WORKS CONSTRUCTION	SECTION:
			UNPAVED ROAD SECTION/ AT-GRADE SERVICE ROAD	DOUGLAS COUNTY
				DATE: DEC. 2018
				DWG: A03-A

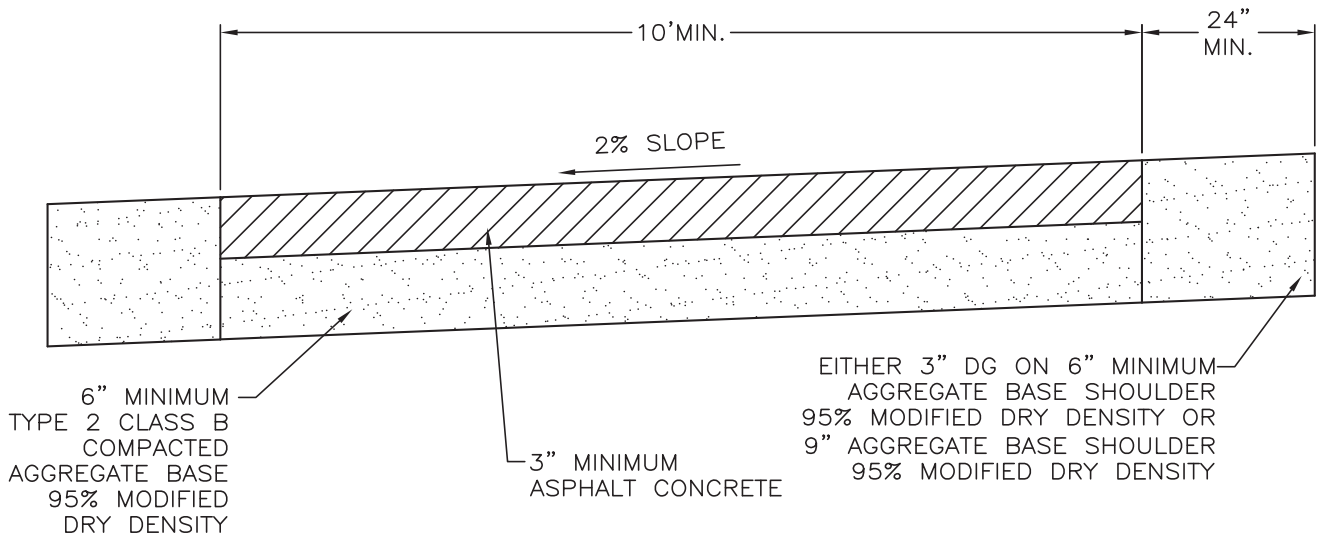

PAVED

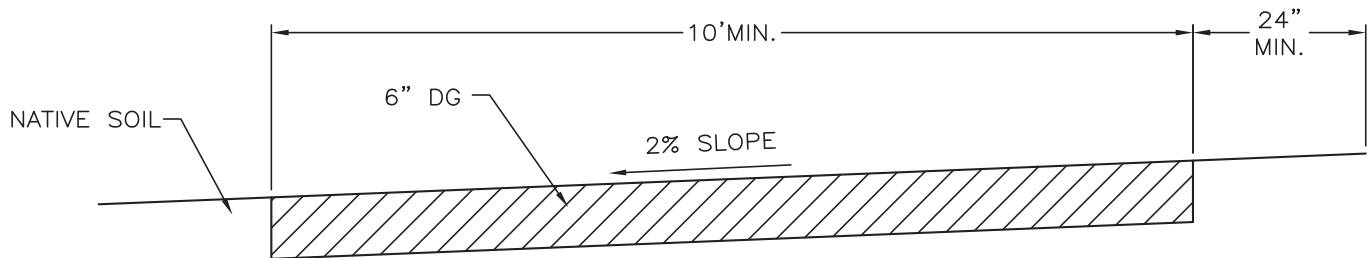

UNPAVED

NOTES:

1. TYPE 3 PLANTMIX BITUMINOUS MIX WITH PG 64-28 NV ASPHALT CEMENT SHALL BE USED.
2. PREPARE SUBGRADE IN CONFORMANCE WITH SECTION 302 OF THE STANDARD SPECIFICATIONS FOR PUBLIC WORKS CONSTRUCTION.
3. BICYCLE FACILITIES SHALL BE DESIGNED IN CONFORMANCE WITH CURRENT AASHTO STANDARDS.

NO.	REVISION	DATE	STANDARD DETAIL FOR PUBLIC WORKS CONSTRUCTION	SECTION: DOUGLAS COUNTY
			PEDESTRIAN PATH/BIKEWAY CLASS I	DATE: JULY 2017
				DWG: A04

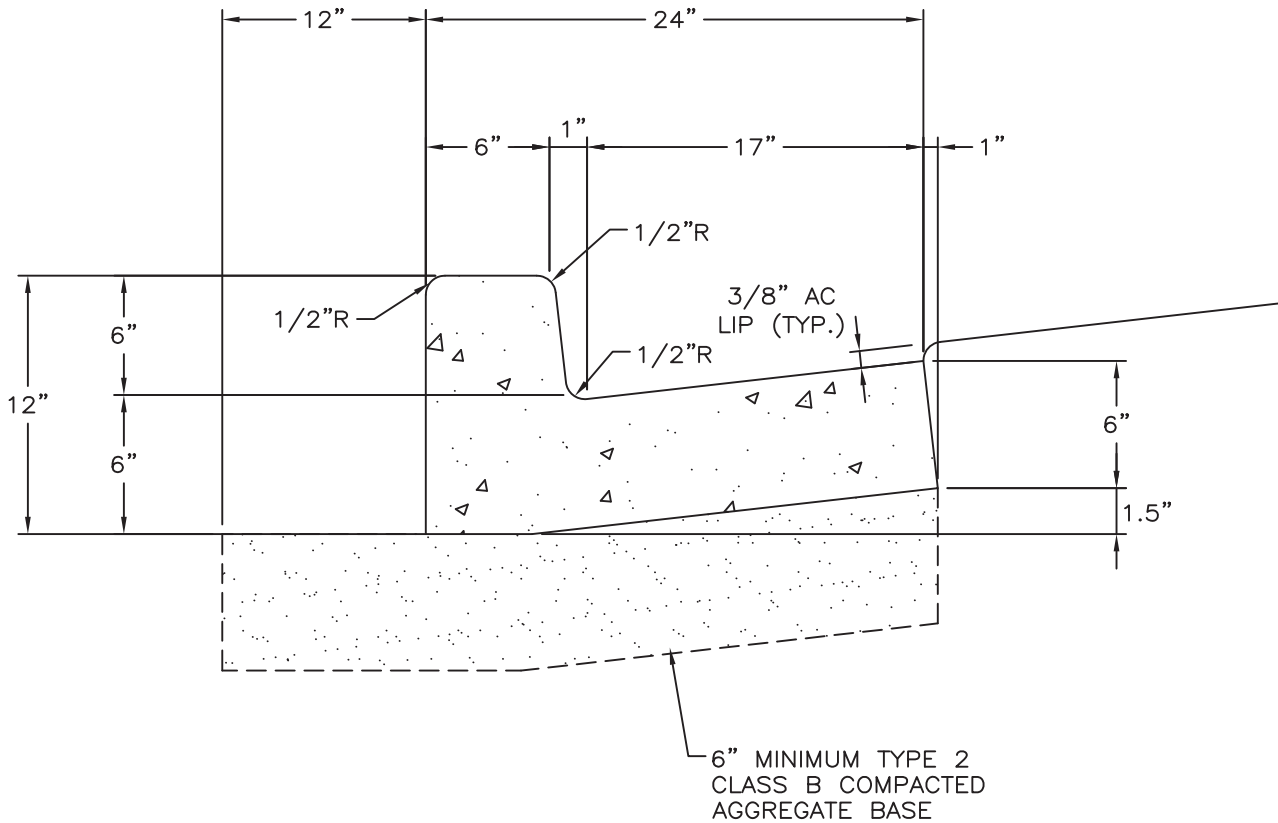

NOTES:

1. PORTLAND CEMENT CONCRETE SHALL CONFORM TO THE REQUIREMENTS OF SECTION 337 OF THE STANDARD SPECIFICATIONS FOR PUBLIC WORKS CONSTRUCTION FOR CONCRETE EXPOSED TO FREEZE-THAW ENVIRONMENTS.
2. WEAKENED PLANE JOINTS SHALL BE CONSTRUCTED EVERY 10 FEET. THE JOINTS SHALL BE CONSTRUCTED IN CONFORMANCE WITH SECTION 312 OF THE STANDARD SPECIFICATIONS FOR PUBLIC WORKS CONSTRUCTION.
3. EXPANSION JOINTS SHALL BE CONSTRUCTED AT LOCATIONS DESIGNATED IN SECTION 312 OF THE STANDARD SPECIFICATIONS FOR PUBLIC WORKS CONSTRUCTION.
4. TYPE 2, CLASS B AGGREGATE BASE SHALL CONFORM TO SECTION 200 OF THE STANDARD SPECIFICATIONS FOR PUBLIC WORKS CONSTRUCTION, AND SHALL BE MECHANICALLY COMPACTED IN CONFORMANCE WITH SECTION 308 OF THE STANDARD SPECIFICATIONS FOR PUBLIC WORKS CONSTRUCTION.

NO.	REVISION	DATE	STANDARD DETAIL FOR PUBLIC WORKS CONSTRUCTION	SECTION: DOUGLAS COUNTY
			<p>TYPE 1 PCC CURB & GUTTER</p>	DATE: JULY 2017
				DWG: A05-A

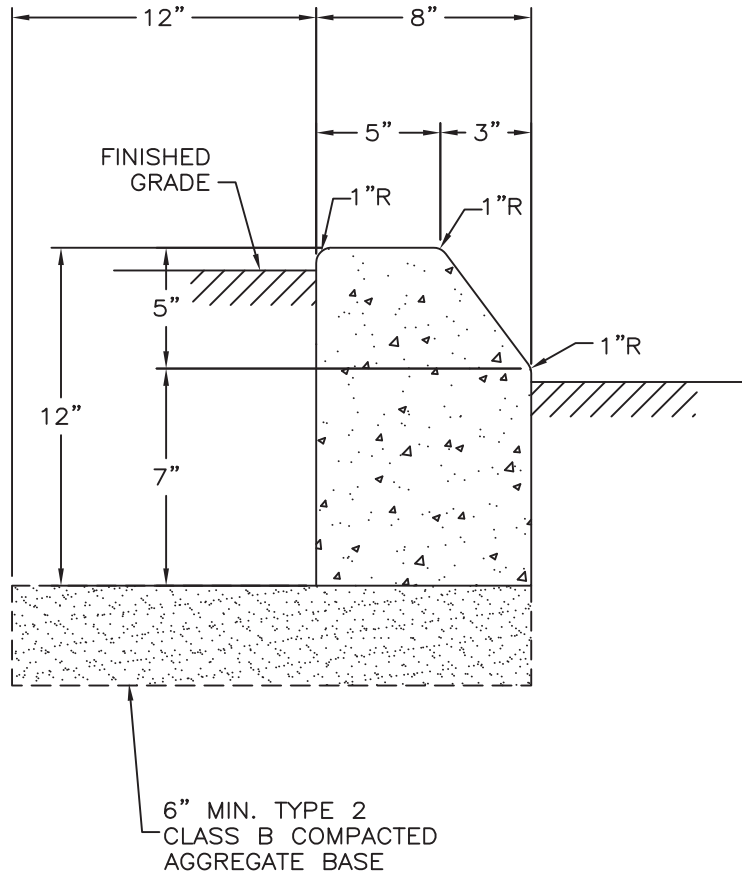

NOTES:

1. PORTLAND CEMENT CONCRETE SHALL CONFORM TO THE REQUIREMENTS OF SECTION 337 OF THE STANDARD SPECIFICATIONS FOR PUBLIC WORKS CONSTRUCTION FOR CONCRETE EXPOSED TO FREEZE-THAW ENVIRONMENTS.
2. WEAKENED PLANE JOINTS SHALL BE CONSTRUCTED EVERY 10 FEET. THE JOINTS SHALL BE CONSTRUCTED IN CONFORMANCE WITH SECTION 312 OF THE STANDARD SPECIFICATIONS FOR PUBLIC WORKS CONSTRUCTION.
3. EXPANSION JOINTS SHALL BE CONSTRUCTED AT LOCATIONS DESIGNATED IN SECTION 312 OF THE STANDARD SPECIFICATIONS FOR PUBLIC WORKS CONSTRUCTION.
4. TYPE 2, CLASS B AGGREGATE BASE SHALL CONFORM TO SECTION 200 OF THE STANDARD SPECIFICATIONS FOR PUBLIC WORKS CONSTRUCTION, AND SHALL BE MECHANICALLY COMPACTED IN CONFORMANCE WITH SECTION 308 OF THE STANDARD SPECIFICATIONS FOR PUBLIC WORKS CONSTRUCTION.

NO.	REVISION	DATE	STANDARD DETAIL FOR PUBLIC WORKS CONSTRUCTION	SECTION: DOUGLAS COUNTY
			PCC MEDIAN CURB	DATE: JULY 2017
				DWG: A05-B

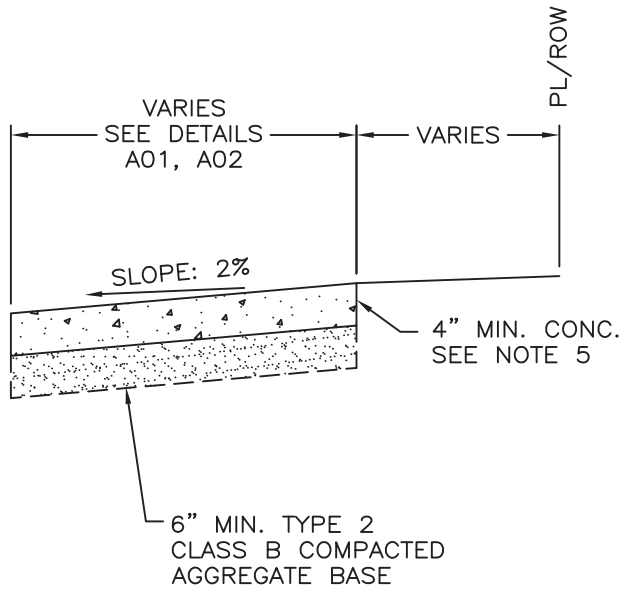

NOTES:

1. PORTLAND CEMENT CONCRETE SHALL CONFORM TO THE REQUIREMENTS OF SECTION 337 OF THE STANDARD SPECIFICATIONS FOR PUBLIC WORKS CONSTRUCTION FOR CONCRETE EXPOSED TO FREEZE-THAW ENVIRONMENTS.
2. WEAKENED PLANE JOINTS SHALL BE CONSTRUCTED EVERY 10 FEET. ON SIDEWALKS WIDER THAN 5 FEET, THE JOINTING PATTERN SHALL BE 0.8 TO 1.2 TIMES THE WIDTH OF THE SIDEWALK, NOT TO EXCEED 8 FEET. THE JOINTS SHALL PENETRATE TO A DEPTH OF 2 INCHES AND BE CONSTRUCTED IN CONFORMANCE WITH SECTION 312 OF THE STANDARD SPECIFICATIONS FOR PUBLIC WORKS CONSTRUCTION; SEE "PCC JOINTING" DETAIL A11.
3. EXPANSION JOINTS SHALL BE CONSTRUCTED AT LOCATIONS DESIGNATED IN SECTION 312 OF THE STANDARD SPECIFICATIONS FOR PUBLIC WORKS CONSTRUCTION.
4. TYPE 2, CLASS B AGGREGATE BASE SHALL CONFORM TO SECTION 200 OF THE STANDARD SPECIFICATIONS FOR PUBLIC WORKS CONSTRUCTION, AND SHALL BE MECHANICALLY COMPACTED IN CONFORMANCE WITH SECTION 308 OF THE STANDARD SPECIFICATIONS FOR PUBLIC WORKS CONSTRUCTION.
5. CONCRETE SIDEWALK SUBJECT TO COMMERCIAL AND INDUSTRIAL DRIVEWAY TRAFFIC SHALL HAVE A MINIMUM THICKNESS OF 6 INCHES.
6. NO OBSTRUCTION, SUCH AS UTILITY POLES, SIGNAL POLES AND CONTROLS, WATER METER BOXES, PULL BOXES, ETC. ARE ALLOWED WITHIN SIDEWALKS.
7. FOR SIDEWALKS WITHIN DOWNTOWN GARDNERVILLE, PROVIDE TREE GRATES AND CONCRETE SCORING AS REQUIRED BY THE TOWN IN CONFORMANCE WITH THE TOWN'S TREE GRATE AND STAMP DETAIL. SEE SEPARATE TOWN OF MINDEN DETAILS WHERE APPLICABLE.

NO.	REVISION	DATE	STANDARD DETAIL FOR PUBLIC WORKS CONSTRUCTION	SECTION: DOUGLAS COUNTY
			TYPICAL SIDEWALK	DATE: JULY 2017
				DWG: A06

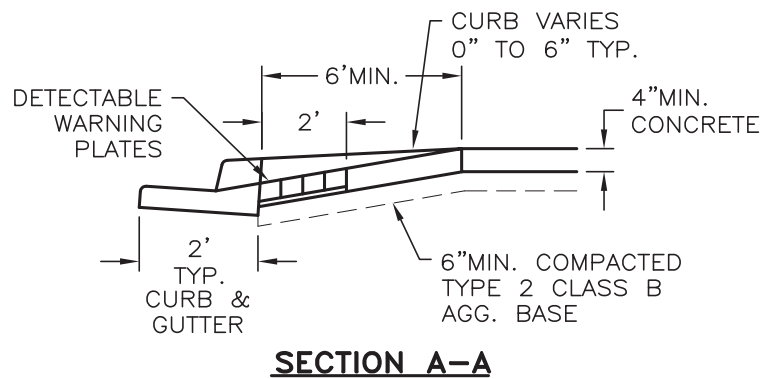
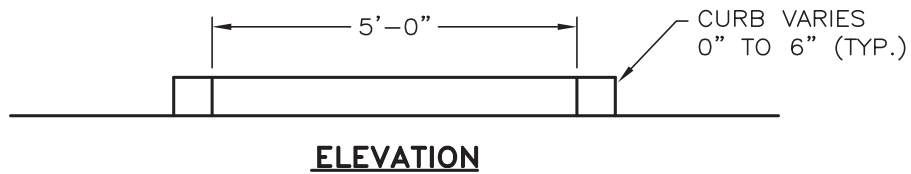
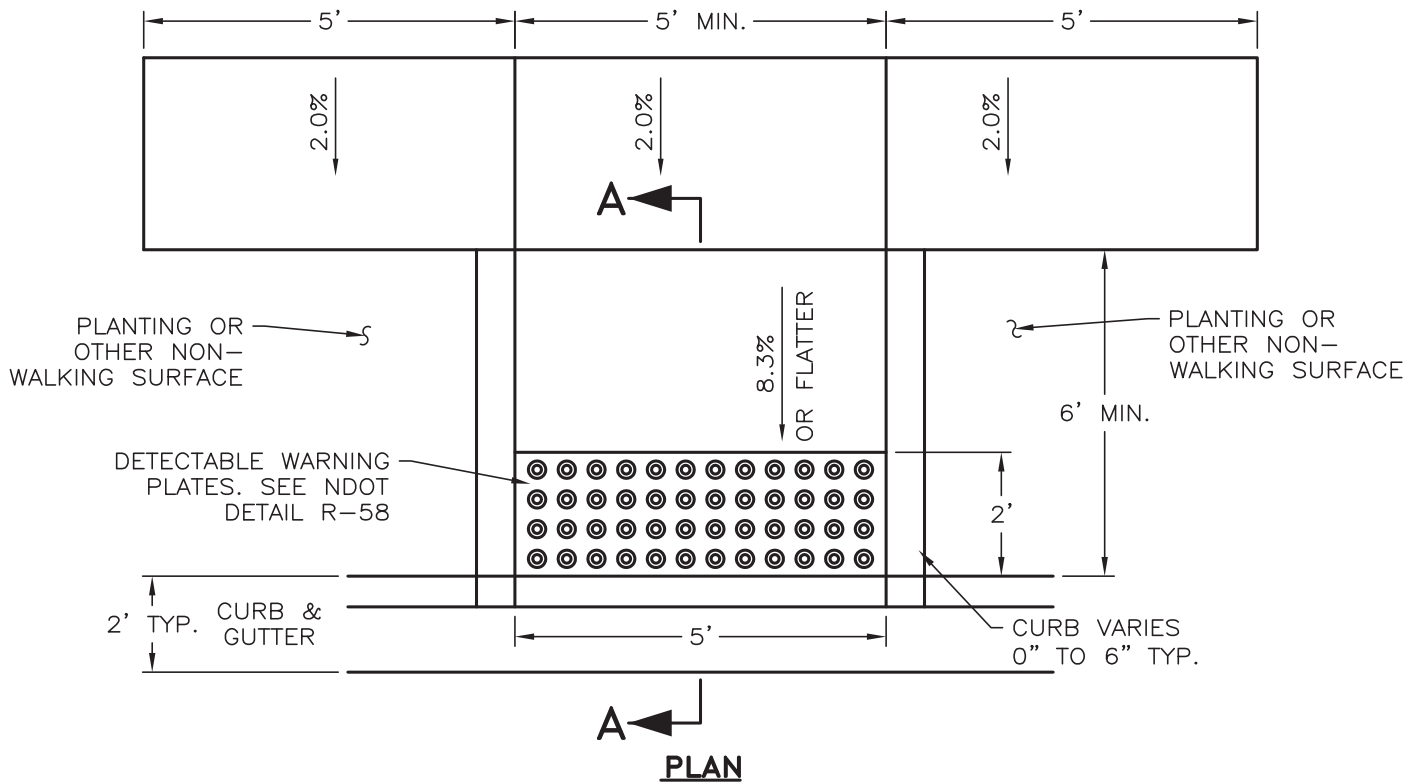

NOTES:

1. SEE "CURB RAMP GENERAL NOTES" DETAIL A07-E FOR FURTHER REQUIREMENTS.

NO.	REVISION	DATE	STANDARD DETAIL FOR PUBLIC WORKS CONSTRUCTION	SECTION: DOUGLAS COUNTY
			MID-BLOCK CURB RAMP WITH DETACHED SIDEWALK	DATE: JULY 2017
				DWG: A07-A

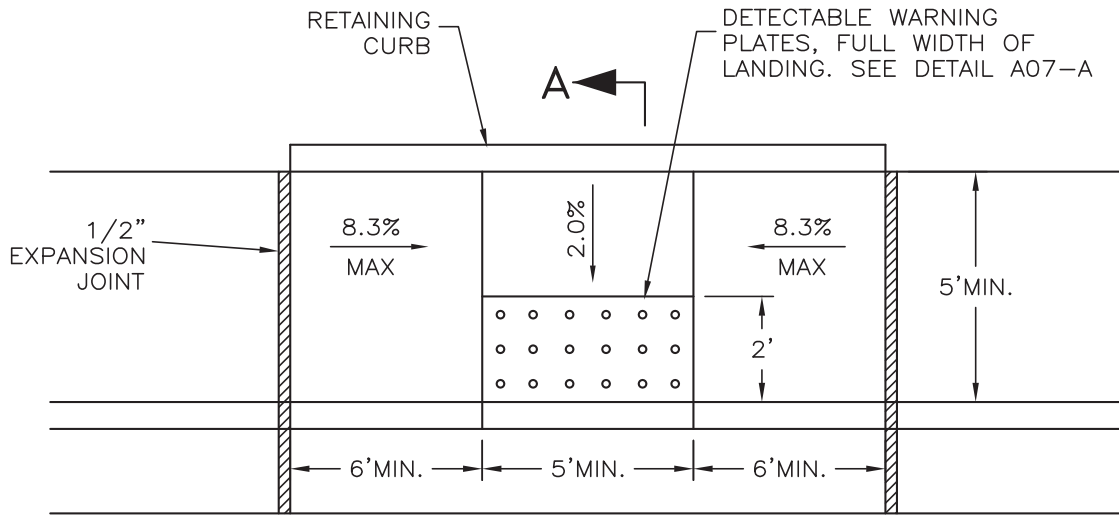

A ←

PLAN
NTS

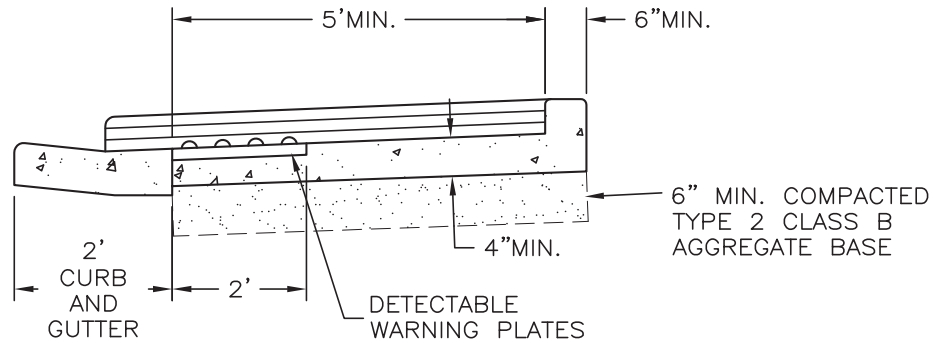

SECTION A-A
NTS

NOTES:

1. RETAINING CURB TO BE USED IN ALL CASES. MAINTAIN SLOPE OF SIDEWALK OUTSIDE OF CURB RAMP.
2. SEE "CURB RAMP GENERAL NOTES" DETAIL A07-E FOR FURTHER REQUIREMENTS.

NO.	REVISION	DATE	STANDARD DETAIL FOR PUBLIC WORKS CONSTRUCTION	SECTION: DOUGLAS COUNTY
			MID-BLOCK CURB RAMP WITH ATTACHED SIDEWALK	DATE: JULY 2017
				DWG: A07-B

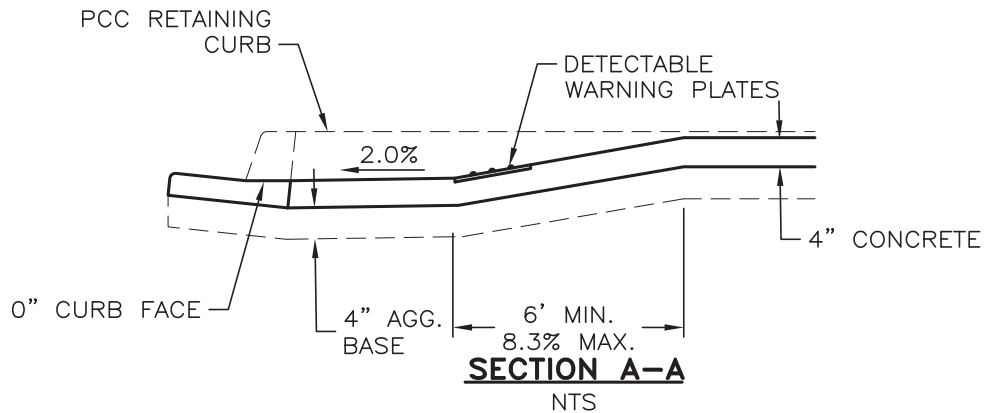
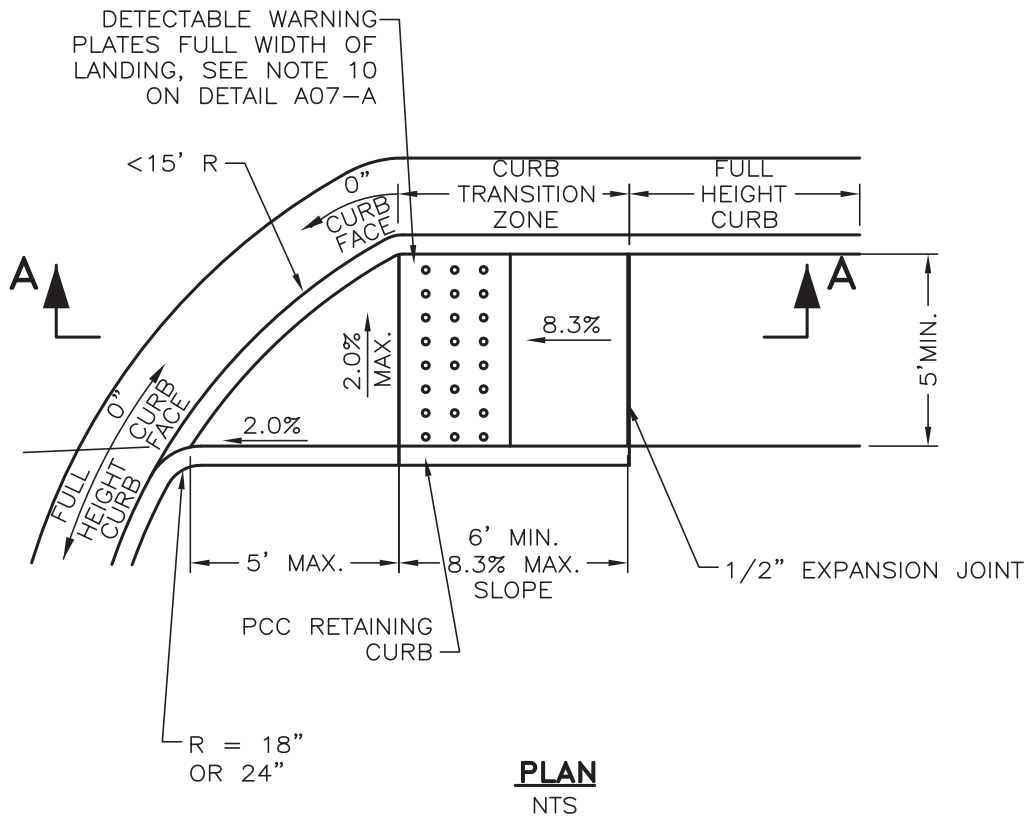

NOTES:

1. LINEAR SINGLE TRANSITION CURB RAMP TO BE USED ONLY AT RETURNS HAVING LESS THAN A 15 FOOT RADIUS. FOR RETURNS WITH A RADIUS GREATER THAN 15' USE NDOT DETAIL R-5.2.1 TYPE A.
2. NOT FOR USE WITH OFFSET SIDEWALKS.
3. RETAINING CURBS ARE TO BE USED IN ALL CASES AND EXISTING GRADE AT BACK OF SIDEWALK IS TO BE RAISED TO TOP OF RETAINING CURB ELEVATION.
4. SEE "CURB RAMP GENERAL NOTES" DETAIL A07-E FOR FURTHER REQUIREMENTS.

NO.	REVISION	DATE	STANDARD DETAIL FOR PUBLIC WORKS CONSTRUCTION	SECTION: DOUGLAS COUNTY
			LINEAR CURB RAMP SINGLE ADJACENT	DATE: JULY 2017
				DWG: A07-C

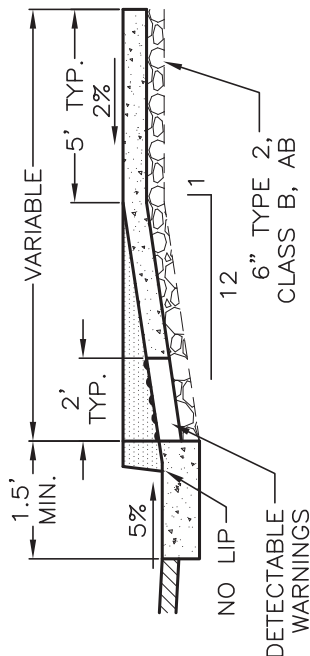
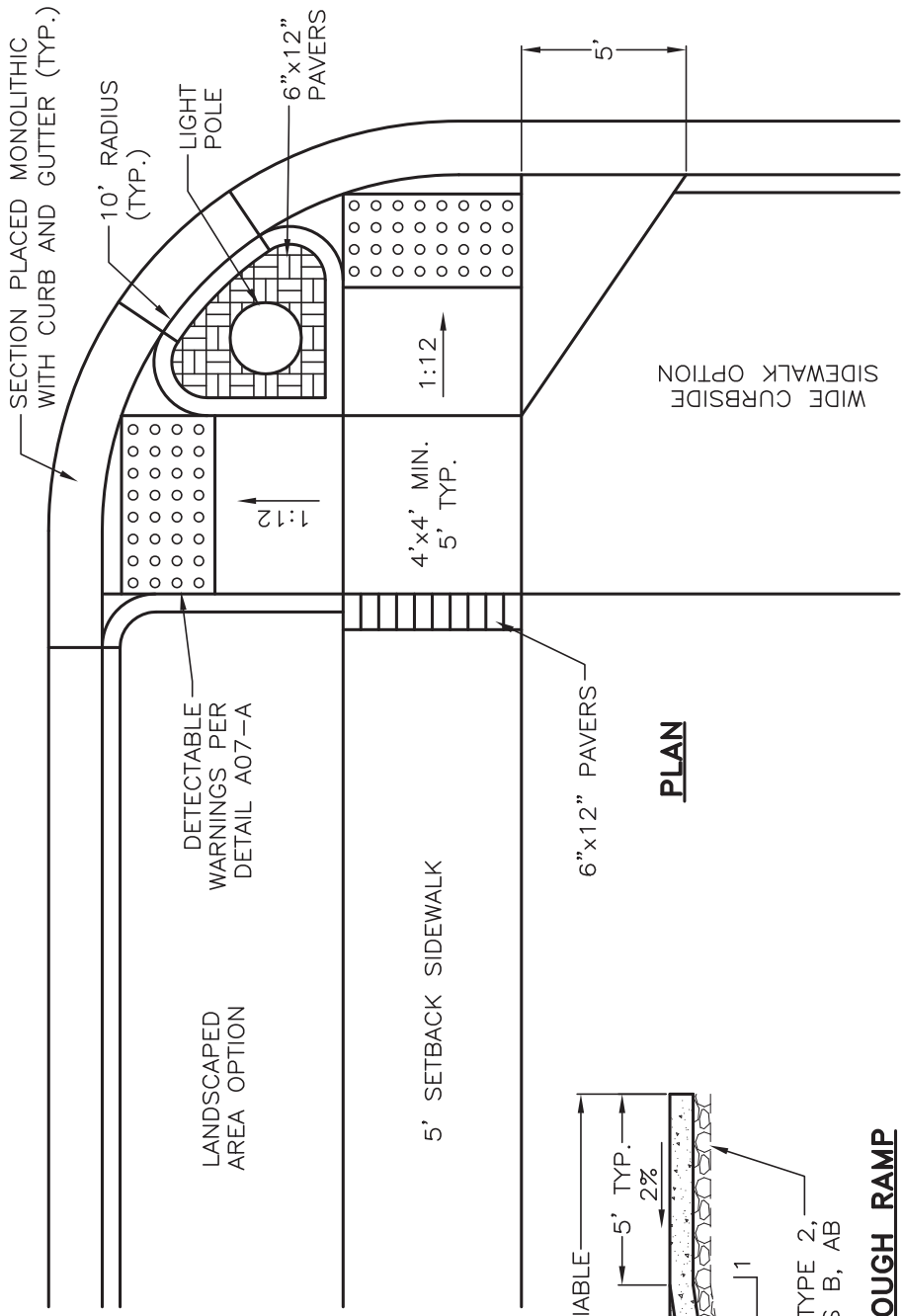

TYPICAL SECTION THROUGH RAMP

NOTES:

1. THE AMERICANS WITH DISABILITIES ACT (ADA) REQUIRES THAT ACCESS RAMPS TO SIDEWALKS CONFORM TO ALL FEDERAL GUIDELINES.
2. NO ABOVE GROUND UTILITIES ARE PERMITTED WITHIN RAMP AREA.
3. TWO PERCENT SLOPED LANDINGS (MAX.) SHALL BE PLACED AT THE TOP OF EACH RAMP. FIVE PERCENT SLOPED LANDING (MAX.) SHALL BE PLACED AT THE BOTTOM OF EACH RAMP.
4. THROAT AREA MUST BE PERPENDICULAR TO THE TRAVEL WAY AND IN LINE WITH THE STRIPED CROSSWALK.

NO.	REVISION	DATE	STANDARD DETAIL FOR PUBLIC WORKS CONSTRUCTION	SECTION:
			ADA PEDESTRIAN RAMPS OLD TOWN CORNER RAMPS	DOUGLAS COUNTY
				DATE: JULY 2017
				DWG: A07-D

NOTES:

1. NO CONCRETE SHALL BE PLACED UNTIL FORMS AND SUBGRADE ARE INSPECTED BY DOUGLAS COUNTY.
2. PORTLAND CEMENT CONCRETE SHALL HAVE THE FOLLOWING CHARACTERISTICS: SYNTHETIC FIBER-REINFORCEMENT (AT A MINIMUM OF 1 POUND PER CUBIC YARD), 4000 PSI MINIMUM COMPRESSIVE STRENGTH AT 28 DAYS, MINIMUM 6 SACKS OF CEMENT PER CUBIC YARD WITH A MAXIMUM WATER/CEMENT RATIO OF 0.45, AIR ENTRAINMENT 6% ±1.5%, SLUMP AT 1 TO 4 INCHES. ALL MATERIALS SHALL CONFORM TO SECTION 337 OF THE STANDARD SPECIFICATIONS FOR PUBLIC WORKS CONSTRUCTION.
3. ALL CONCRETE EDGING AND JOINTING SHALL BE CONSTRUCTED IN CONFORMANCE WITH SECTION 312 OF THE STANDARD SPECIFICATIONS FOR PUBLIC WORKS CONSTRUCTION.
4. IF OBSTRUCTIONS SUCH AS INLETS, UTILITY POLES, FIRE HYDRANTS, ETC., ARE ENCOUNTERED, THE LOCATION AND DIMENSIONS MAY BE ADJUSTED UPON APPROVAL BY DOUGLAS COUNTY. A MINIMUM LANDING OF 5 FEET x 5 FEET CLEAR IS REQUIRED WHEN DIRECTION OF TRAVEL MAY CHANGE. A MINIMUM OF 4 FEET CLEAR MAY BE USED UPON APPROVAL BY DOUGLAS COUNTY WHERE DIRECTION OF TRAVEL IS NOT EXPECTED TO CHANGE. FOR NEW CONSTRUCTION ALL OBSTRUCTIONS SHALL BE LOCATED OUTSIDE OF THE RAMP.
5. WHEN A CROSSWALK IS SERVICED BY RAMP, LANDINGS SHALL BE CONTAINED WITHIN THE CROSSWALK AREA.
6. EXISTING CONCRETE TO BE REMOVED SHALL BE SAW CUT AT THE JOINT.
7. PLANTMIX BITUMINOUS SURFACE SHALL BE FLUSH WITH THE EDGE OF THE GUTTER PAN IN THE AREA OF THE CURB RAMP. GUTTER SHALL MAINTAIN POSITIVE DRAINAGE TO PREVENT PONDING.
8. ALL AGGREGATE BASE SHALL BE TYPE 2 CLASS B AND SHALL CONFORM TO SECTION 200 OF THE STANDARD SPECIFICATIONS FOR PUBLIC WORKS CONSTRUCTION.
9. NEW CONCRETE SHALL HAVE A HEAVY BROOM FINISH PERPENDICULAR TO SIDEWALK.
10. FOR RADIAL INSTALLATIONS WITH OR WITHOUT 6 FOOT MINIMUM LANDSCAPE STRIP, USE NDOT DETAIL R-5.2.1 TYPE A.
11. ALL CURB RAMPS AND SIDEWALKS SHALL COMPLY WITH CURRENT ADA AND PROWAG STANDARDS.
12. ALL CURB RETURN RAMPS SHALL BE PER CURRENT NDOT STANDARDS (R-5.2.1 AND R-5.2.2 AT TIME OF CURRENT PUBLICATION, ATTACHED FOR REFERENCE).

NO.	REVISION	DATE	STANDARD DETAIL FOR PUBLIC WORKS CONSTRUCTION	SECTION: DOUGLAS COUNTY
			CURB RAMP GENERAL NOTES	DATE: JULY 2017
				DWG: A07-E

CURB RAMP TYPE A (NARROW SIDEWALKS)

For A and B, See Table A

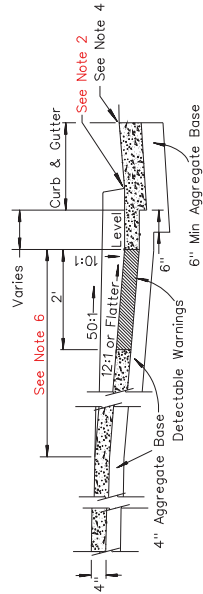
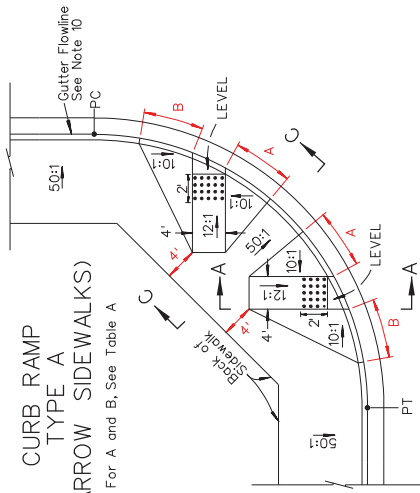

SECTION A-A

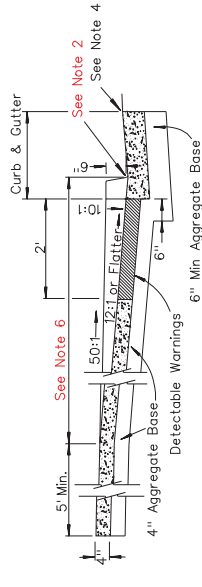

SECTION B-B

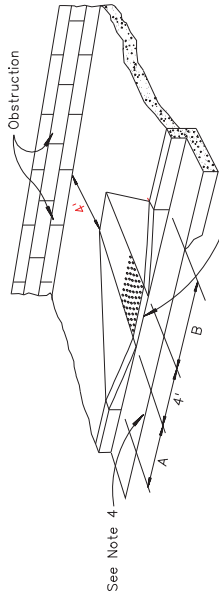

CURB RAMP TYPE B (MID BLOCK)

For A and B, See Table A

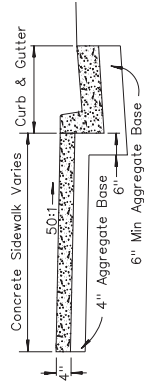

SECTION C-C

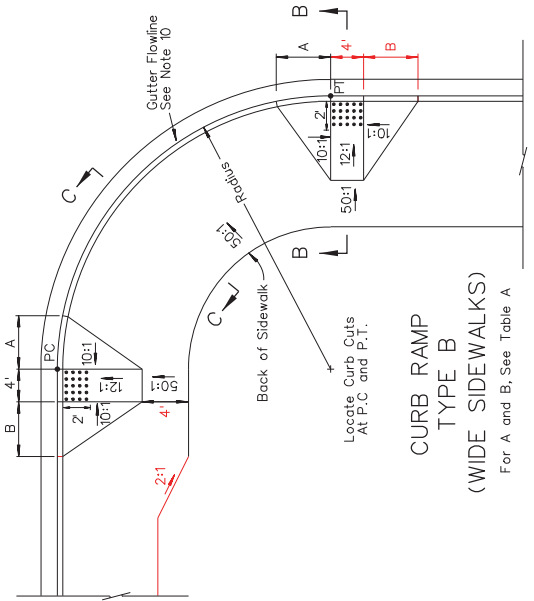

CURB RAMP TYPE B (WIDE SIDEWALKS)

For A and B, See Table A

NOTES:

- GRATINGS OR SIMILAR ACCESSES SHALL NOT BE LOCATED IN AREA AT THE BASE OF THE CURB RAMP OR IN THE RAMP AND LANDING AREA.
- TRANSITIONS FROM RAMPS TO GUTTERS OR ROADWAY SURFACE SHALL BE FLUSH AND FREE OF ABRUPT CHANGES.
- PLANTING BITUMINOUS OPEN-GRADED SURFACE SHALL BE FLUSH WITH THE EDGE OF THE GUTTER AND THE AREA OF THE CURB RAMP, AND FEATHERED AT 12:1 IN LINE WITH THE CROSSWALK.
- ROUGH-BROOM TEXTURE ON CURB RAMPS AND WINGS. TEXTURE SHALL PROVIDE A VISUAL CONTRAST TO THE SIDEWALK.
- CURB RAMP WINGS DO NOT HAVE TO BE WITHIN CROSS-WALK HOWEVER, THE RAMP ITSELF HAS TO BE WITHIN CROSS-WALK.
- ALL RAMPS SHALL BE 12:1 OR FLATTER, 15 MAXIMUM LENGTH.
- ALL SLOPE RATES ARE RELATIVE TO LEVEL.
- CONCRETE SHALL BE CLASS A OR AA.
- RAISE GUTTER FLOWLINE 2" MAX., WHEN REQUIRED TO PREVENT PONDING AT THE RAMP AND MAINTAIN POSITIVE DRAINAGE.
- DETECTABLE WARNINGS SHALL BE INSTALLED PER MANUFACTURERS GUIDELINES AND CONFORM TO PROWAS (R304.1.3) "CONTRAST".
- CURB RAMPS AND DETECTABLE WARNINGS SHALL BE ALIGNED IN THE SAME DIRECTION AS THE CROSS-WALK.

DESIGN NOTES:

- IF THERE ARE R/W RESTRICTIONS THEN THE SIDEWALK WIDTH CAN BE REDUCED TO NO LESS THAN 4 FEET WITH APPROVAL OF THE ASSISTANT CHIEF ROAD DESIGN ENGINEER. IF THE SIDEWALK WIDTH IS LESS THAN 5 FEET THEN 5-FOOT BY 5-FOOT PASSING ZONES ARE REQUIRED AT 200-FOOT INTERVALS.

TABLE A

GRADE %	A MIN.	B MIN.
-6 TO -5.01	4'	12' - 6"
-5 TO -4.01	4'	10' - 6"
-4 TO -3.01	4'	7' - 6"
-3 TO -2.01	4' - 6"	6' - 6"
-2 TO -1.01	5' - 6"	5' - 6"
1.01 TO 2	7' - 6"	4'
2.01 TO 3	8' - 6"	4'
3.01 TO 4	10'	4'
4.01 TO 5	12' - 6"	4'
5.01 TO 6	12' - 6"	4'

LEGEND:

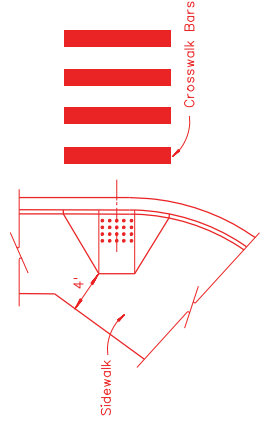
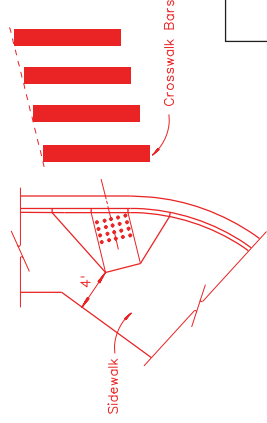

CURB RAMP/CROSSWALK ALIGNMENT

See Note 11

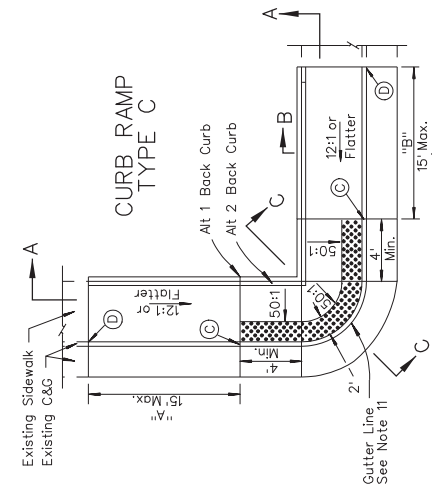

TABLE 1-12

GRADE % "B" TO "A"	"A" MIN.	"B" MIN.
> -4.00	4' - 6"	15'
-4 TO -3.01	4' - 6"	12'
-3 TO -2.01	5' - 6"	9' - 6"
-2 TO -1.01	5' - 6"	8'
-1 TO 1	7'	7'
1.01 TO 2	8' - 6"	5' - 6"
2.01 TO 3	9' - 6"	5' - 6"
3.01 TO 4	12'	4' - 6"
> 4.00	15'	4' - 6"

ALT

Alt 1: Back Curb Outside Ramp - No R/W Restrictions
Alt 2: Back Curb Inside Ramp - If R/W Restrictions
Alt 3: No Back Curb

SEE TABLE 1-12 FOR "A" and "B" LENGTHS

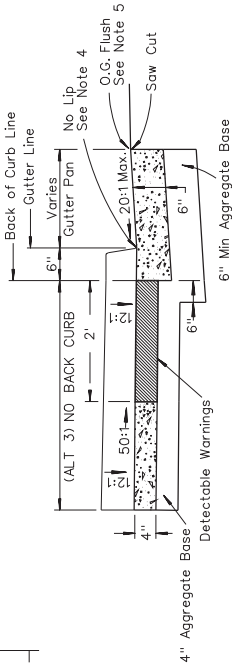
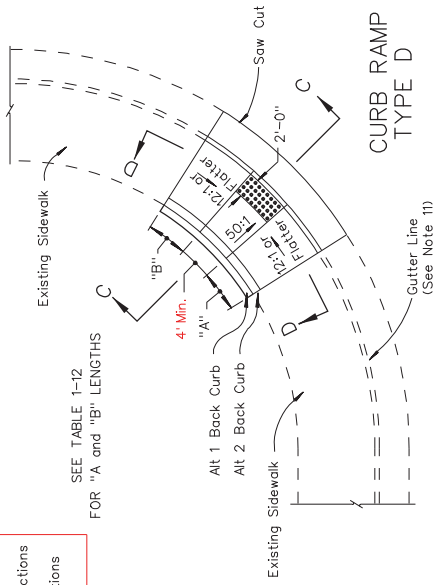

SECTION C-C WITHOUT BACK CURB

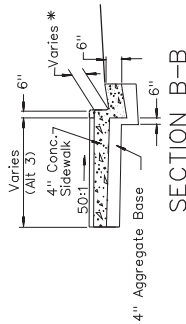

SECTION B-B

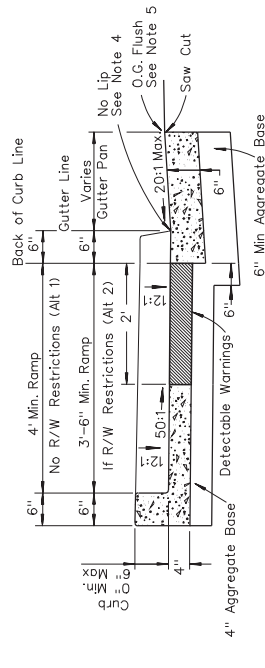

SECTION C-C WITH BACK CURB

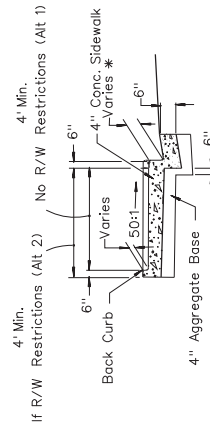

SECTION B-B WITH BACK CURB

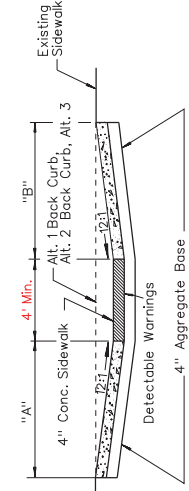

SECTION D-D

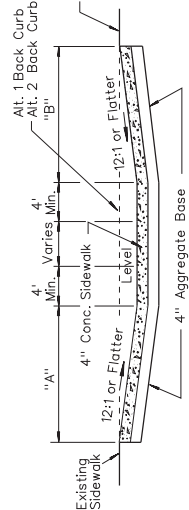

SECTION A-A

NOTES:

- IF RIGHT-OF-WAY IS AVAILABLE, USE TYPE A CURB RAMP.
- SEE STRUCTURE LIST AND PLAN SHEETS FOR "A" AND "B".
- GRATINGS, OR SIMILAR ACCESSES SHALL NOT BE LOCATED IN AREA AT THE BASE OF THE CURB RAMP OR LANDING AREA.
- TRANSITIONS FROM RAMPS TO GUTTERS OR ROADWAY SURFACE SHALL BE FLUSH AND FREE OF ABRUPT CHANGES. GRINDING SHALL BE 6" MINIMUM PERPENDICULAR TO FLOW LINE FOR RETROFIT.
- PLANT MIX BITUMINOUS OPEN-GRADED SURFACE SHALL BE FLUSH WITH THE EDGE OF THE GUTTER PAN IN THE AREA OF THE CURB RAMP. GRINDING WIDTH 9" MINIMUM OR 12:1 PLANT MIX BITUMINOUS SURFACE MINIMUM FOR RETROFIT.
- ROUGH BROOM TEXTURE ON CURB RAMPS AND WINGS. TEXTURE SHALL PROVIDE A VISUAL CONTRAST TO THE SIDEWALK.
- ALL RAMPS SHALL BE 12:1 OR FLATTER, 15' MAXIMUM LENGTH
- ALL SLOPE RATES ARE RELATIVE TO LEVEL.
- CONCRETE SHALL BE CLASS A OR AA.
- ADJUST FLOWLINE WHEN REQUIRED TO PREVENT PONDING AT THE RAMP AND MAINTAIN POSITIVE DRAINAGE.
- DETECTABLE WARNING SHALL BE INSTALLED PER MANUFACTURERS GUIDELINES AND CONFORM TO PROWAG (R304.1.13) "CONTRAST".
- NO DIRECT PAYMENT FOR NEAT LINE SAW CUT. AN ADDITIONAL 1' OF PAVEMENT MAY BE REQUIRED. IF ELECTING TO REMOVE AN ADDITIONAL 1' MATCH EXISTING STRUCTURAL SECTION WITH PATCH; NO ADJUSTMENT TO THE PLAN QUANTITIES FOR REMOVAL AND PATCHING.

LEGEND:

* FROM 0" AT @ TO 6" AT @

DETECTABLE WARNINGS

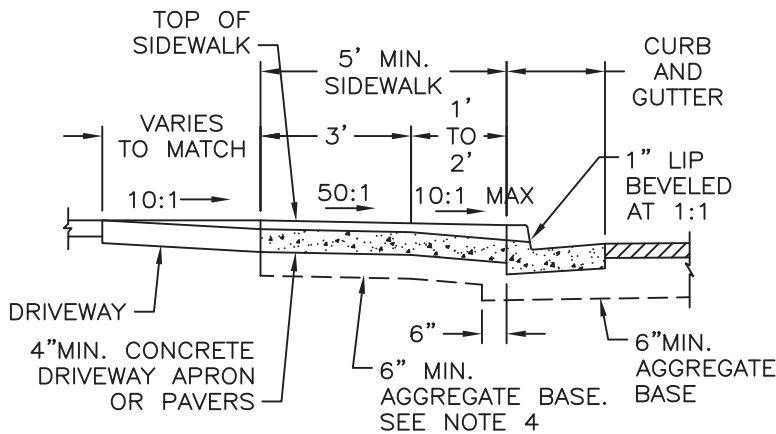
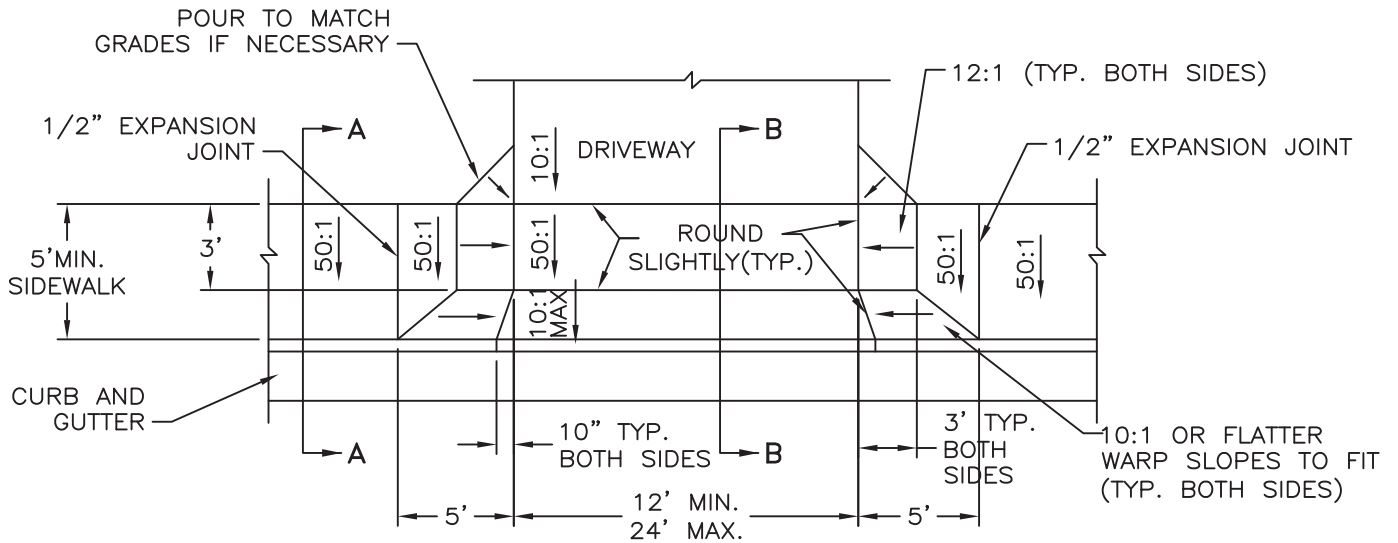

SECTION B-B

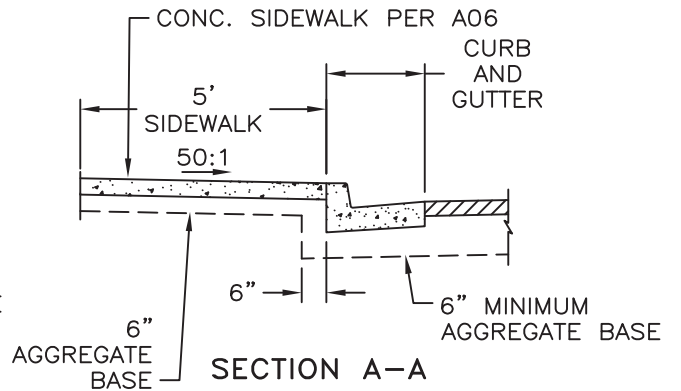

SECTION A-A

NOTES:

1. PORTLAND CEMENT CONCRETE SHALL CONFORM TO THE REQUIREMENTS OF SECTION 337 OF THE STANDARD SPECIFICATIONS FOR PUBLIC WORKS CONSTRUCTION FOR CONCRETE EXPOSED TO FREEZE-THAW ENVIRONMENTS.
2. WEAKENED PLANE JOINTS SHALL BE CONSTRUCTED EVERY 5 FEET. THE JOINTS SHALL PENETRATE TO A DEPTH OF 2 INCHES AND BE CONSTRUCTED IN CONFORMANCE WITH SECTION 312 OF THE STANDARD SPECIFICATIONS FOR PUBLIC WORKS CONSTRUCTION.
3. EXPANSION JOINTS SHALL BE CONSTRUCTED AT LOCATIONS DESIGNATED IN SECTION 312 OF THE STANDARD SPECIFICATIONS FOR PUBLIC WORKS CONSTRUCTION.
4. TYPE 2 CLASS B AGGREGATE BASE SHALL CONFORM TO SECTION 200 OF THE STANDARD SPECIFICATIONS FOR PUBLIC WORKS CONSTRUCTION, AND SHALL BE MECHANICALLY COMPACTED IN CONFORMANCE WITH SECTION 308 OF THE STANDARD SPECIFICATIONS FOR PUBLIC WORKS CONSTRUCTION.
5. SPECIAL DESIGN WILL BE REQUIRED TO ENSURE ADA COMPLIANCE IN THE CASE OF EXISTING ATTACHED SIDEWALK.

NO.	REVISION	DATE	STANDARD DETAIL FOR PUBLIC WORKS CONSTRUCTION	SECTION: DOUGLAS COUNTY
			<p>URBAN RESIDENTIAL PCC DRIVEWAY APRON</p>	DATE: JULY 2017
				DWG: A08-A

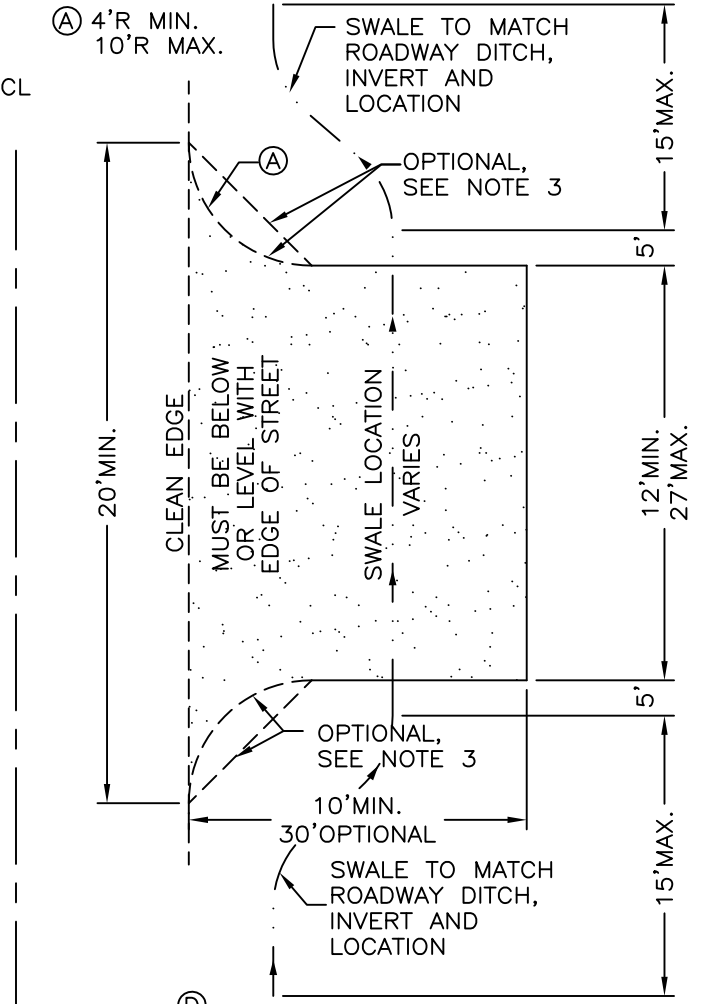
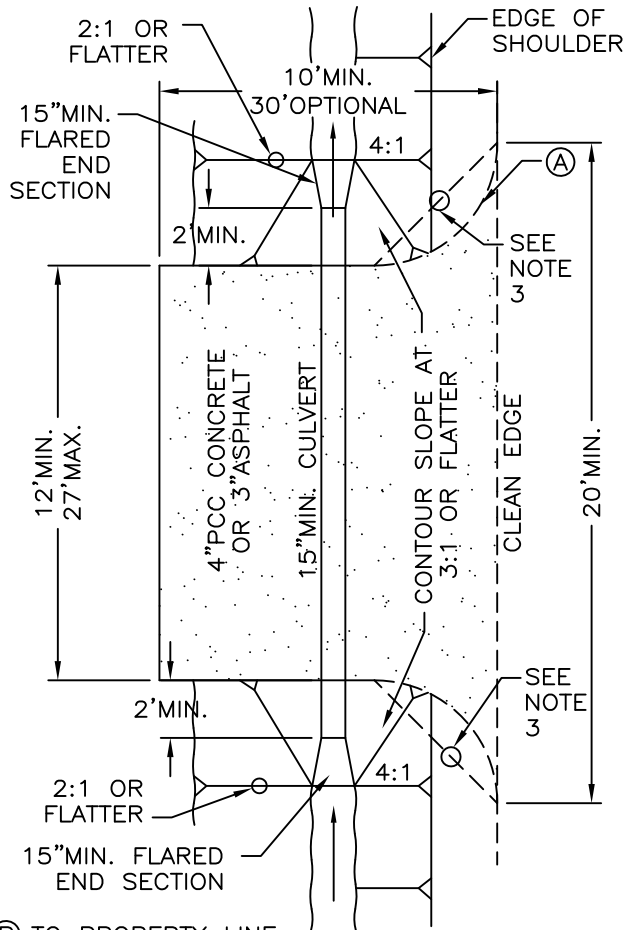

- (B) TO PROPERTY LINE
- (C) 4' MIN. OR WIDTH OF SHOULDER
- (D) 4% - 6%

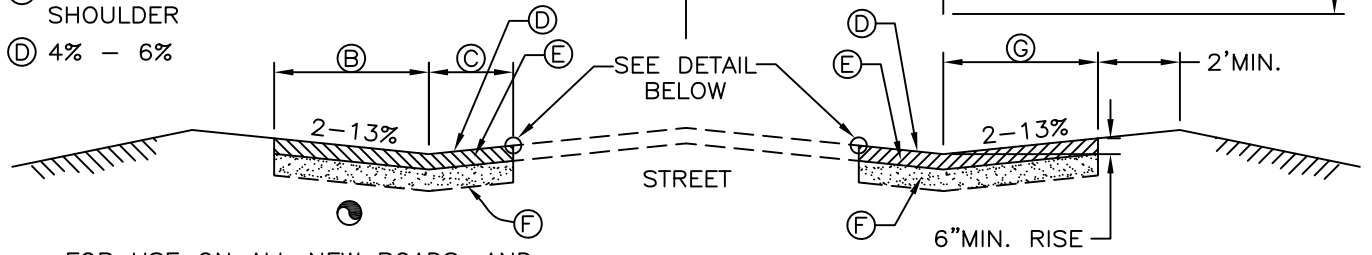

FOR USE ON ALL NEW ROADS, AND EXISTING ROADS WHERE DITCH IS GREATER THAN 2' BELOW EDGE OF PAVEMENT

FOR USE ON EXISTING ROADS WHERE DITCH IS LESS THAN 2' BELOW EDGE OF PAVEMENT

- (E) ASPHALT CONCRETE 3" MIN. OR 4" MIN. PCC
- (F) 6" TYPE 2 CLASS B AGGREGATE BASE

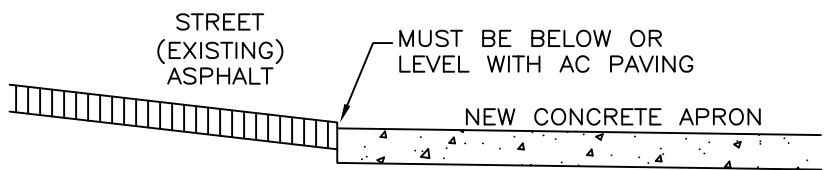

- (G) 4' MIN. OR TO PROPERTY LINE

NOTES:

1. TYPE 2 CLASS B AGGREGATE BASE SHALL CONFORM TO SECTION 200 OF THE STANDARD SPECIFICATIONS FOR PUBLIC WORKS CONSTRUCTION, AND SHALL BE MECHANICALLY COMPACTED IN CONFORMANCE WITH SECTION 308 OF THE STANDARD SPECIFICATIONS FOR PUBLIC WORKS CONSTRUCTION.
2. TYPE 3 AGGREGATE BASE SHALL BE USED FOR ASPHALT CONCRETE IN CONFORMANCE WITH SECTION 200 OF THE STANDARD SPECIFICATIONS FOR PUBLIC WORKS CONSTRUCTION. ASPHALT CONCRETE MATERIALS AND CONSTRUCTION SHALL CONFORM TO SECTION 320 OF THE STANDARD SPECIFICATIONS FOR PUBLIC WORKS CONSTRUCTION.
3. OPTIONAL: RETURN MAY BE STRAIGHT OR RADIUS.

NO.			REVISION	DATE	STANDARD DETAIL FOR PUBLIC WORKS CONSTRUCTION	SECTION:	
<h1>RURAL RESIDENTIAL DRIVEWAY APRON</h1>						DOUGLAS COUNTY	
						DATE:	DEC 2018
						DWG:	A08-B

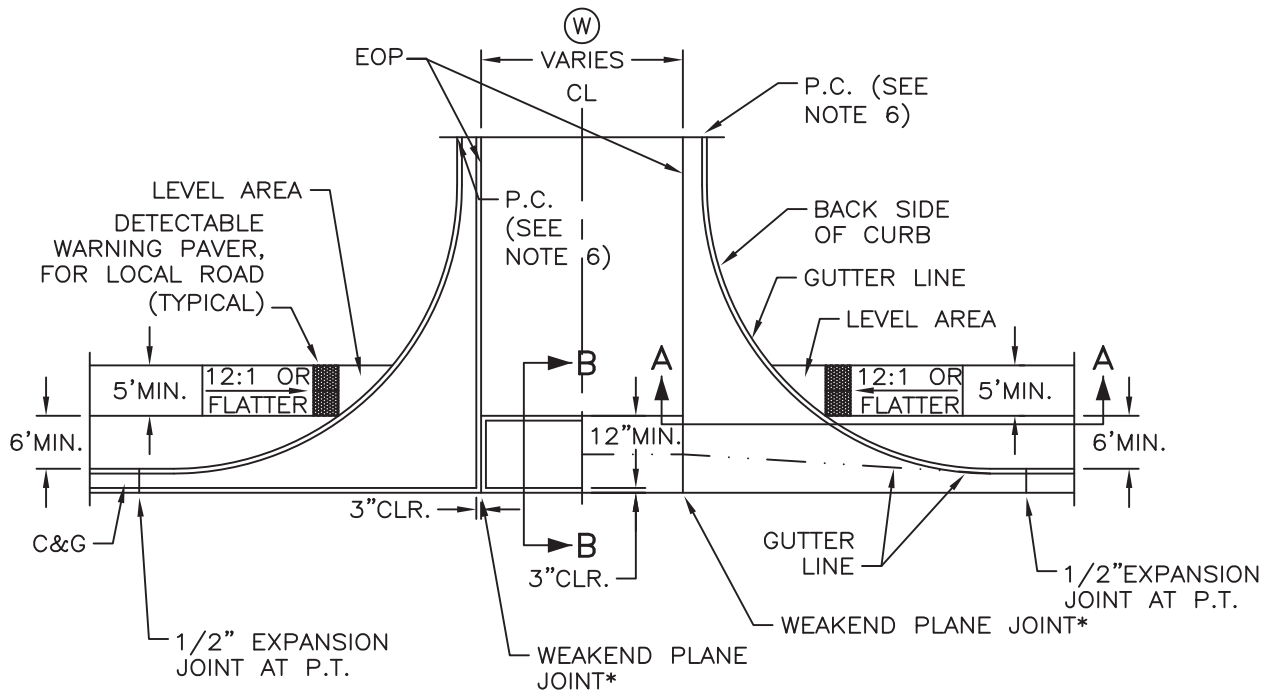

* SEE NOTE 1
 ** FOR OPTIONAL SECTIONAL POUR, SEE NOTE 2

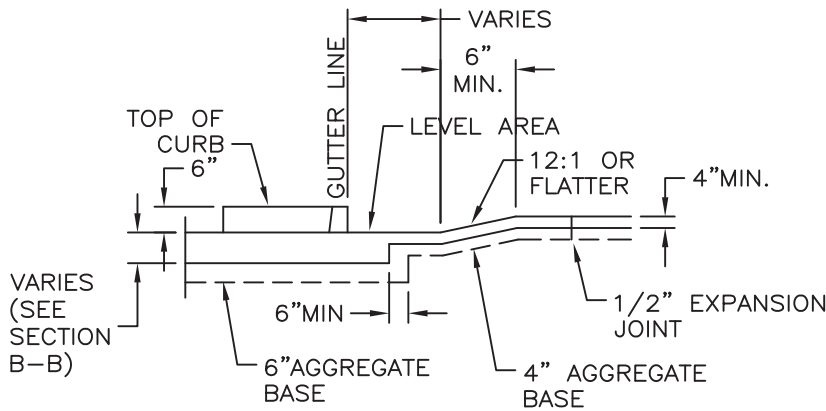

SECTION A-A

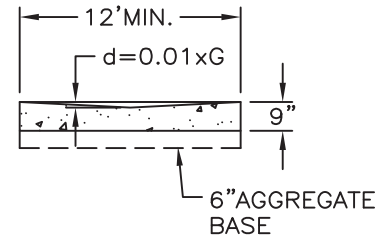

SECTION B-B

(W)
W. 15' MINIMUM FOR ONE-WAY DRIVEWAYS 30' MINIMUM FOR TWO-WAY DRIVEWAYS, 40' MAXIMUM. 32' FOR LOCAL ROADS 34' FOR LIGHT COMMERCIAL DRIVEWAY 54' FOR HEAVY COMMERCIAL/INDUSTRIAL DRIVEWAY

- (S) = SIDEWALK
- (G) = WIDTH OF VALLEY GUTTER (12' MINIMUM)

NO.	REVISION	DATE	STANDARD DETAIL FOR PUBLIC WORKS CONSTRUCTION	SECTION: DOUGLAS COUNTY
			PCC DRIVEWAY APRON (NON-RESIDENTIAL) & LOCAL ROAD VALLEY GUTTER	DATE: JULY 2017
				DWG: A08-C

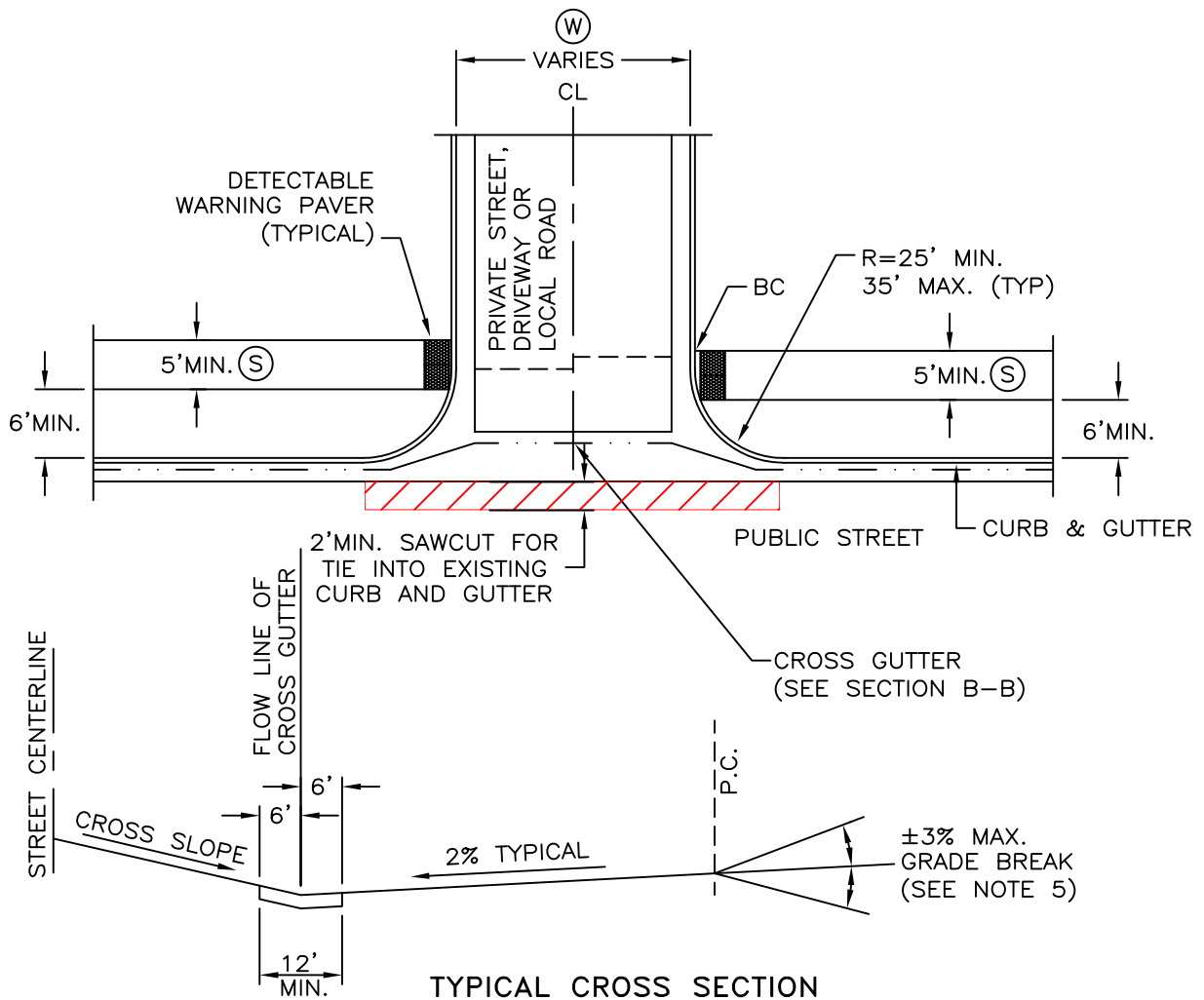

TYPICAL CROSS SECTION AT CENTERLINE

NOTES:

- IF NOT COMPLETED WITH MONOLITHIC POUR OR IF REPLACEMENT OF EXISTING PANEL, DOWEL NO.4 BARS AT MID SLAB DEPTH 4" O.C. MINIMUM EMBED IN BOTH SLABS SHALL BE 6".
- WHEN CONSTRUCTING APRONS WHERE CURB AND GUTTER EXISTS, COMPLETELY REMOVE EXISTING SECTIONS. APRON MAY BE POURED MONOLITHIC TO AC LINE, IN WHICH CASE THE BARS SHALL BE CONTINUOUS. IF OPTIONAL SECTIONAL POUR IS USED, WEAKEND PLANE JOINTS AND REBAR END CLEARANCE SHALL APPLY AS SHOWN.
- CONCRETE SHALL CONFORM TO THE REQUIREMENTS OF SECTION 337 OF THE STANDARD SPECIFICATIONS FOR PUBLIC WORKS CONSTRUCTION FOR CONCRETE EXPOSED TO FREEZE-THAW ENVIRONMENTS.
- CURB RAMPS SHALL BE CONSTRUCTED IN CONFORMANCE WITH "CURB RAMP" DETAIL A07-C OR USE NDOT DETAIL R-5.2.1 TYPE A.
- FOR GRADE CHANGES GREATER THAN 3% VERTICAL CURVES OF AT LEAST 10 FEET MUST BE USED. SPANDREL AND VALLEY GUTTER MUST BE POURED MONOLITHICALLY.
- DRIVEWAY GEOMETRICS SHALL GO TO THE BC.
- PORTLAND CEMENT CONCRETE SHALL HAVE THE FOLLOWING CHARACTERISTICS: SYNTHETIC FIBER-REINFORCEMENT (AT A MINIMUM OF 1 POUND PER CUBIC YARD), 4000 PSI MINIMUM COMPRESSIVE STRENGTH AT 28 DAYS, MINIMUM 6 SACKS OF CEMENT PER CUBIC YARDS WITH A MAXIMUM WATER/CEMENT RATIO OF 0.45, AIR ENTRAINMENT 6% ±1.5%, SLUMP AT 1 TO 4 INCHES. ALL MATERIALS SHALL CONFORM TO SECTION 202 OF THE STANDARD SPECIFICATIONS FOR PUBLIC WORKS CONSTRUCTION.
- THIS DETAIL ALSO APPLIES TO NON-RESIDENTIAL AND MULTI-FAMILY RESIDENTIAL DRIVEWAYS.

NO.	REVISION	DATE	STANDARD DETAIL FOR PUBLIC WORKS CONSTRUCTION	SECTION: DOUGLAS COUNTY
			PCC DRIVEWAY APRON (NON-RESIDENTIAL) & LOCAL ROAD VALLEY GUTTER	DATE: DEC 2018
				DWG: A08-C

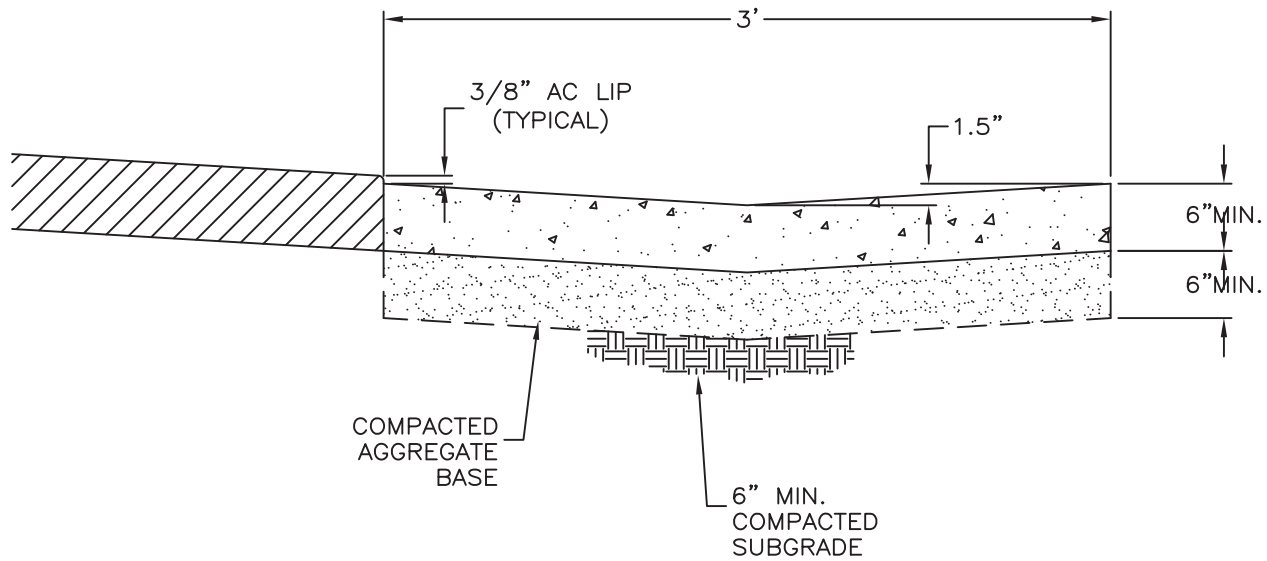

NOTES:

1. AGGREGATE BASE SHALL BE TYPE 2, CLASS B AND BE COMPACTED IN CONFORMANCE WITH SECTION 308 OF THE STANDARD SPECIFICATIONS FOR PUBLIC WORKS CONSTRUCTION.
2. PORTLAND CEMENT CONCRETE SHALL CONFORM TO THE REQUIREMENTS OF SECTION 337 OF THE STANDARD SPECIFICATIONS FOR PUBLIC WORKS CONSTRUCTION FOR CONCRETE EXPOSED TO FREEZE-THAW ENVIRONMENTS. CONCRETE SHALL INCLUDE SYNTHETIC FIBER-REINFORCEMENT. CONCRETE PER ORANGE BOOK 337.
3. FOR ALLEYS AND PARKING LOTS ONLY.

NO.	REVISION	DATE	STANDARD DETAIL FOR PUBLIC WORKS CONSTRUCTION	SECTION: DOUGLAS COUNTY
			<h1>PCC VALLEY GUTTER (ALLEYS)</h1>	DATE: JULY 2017
				DWG: A09

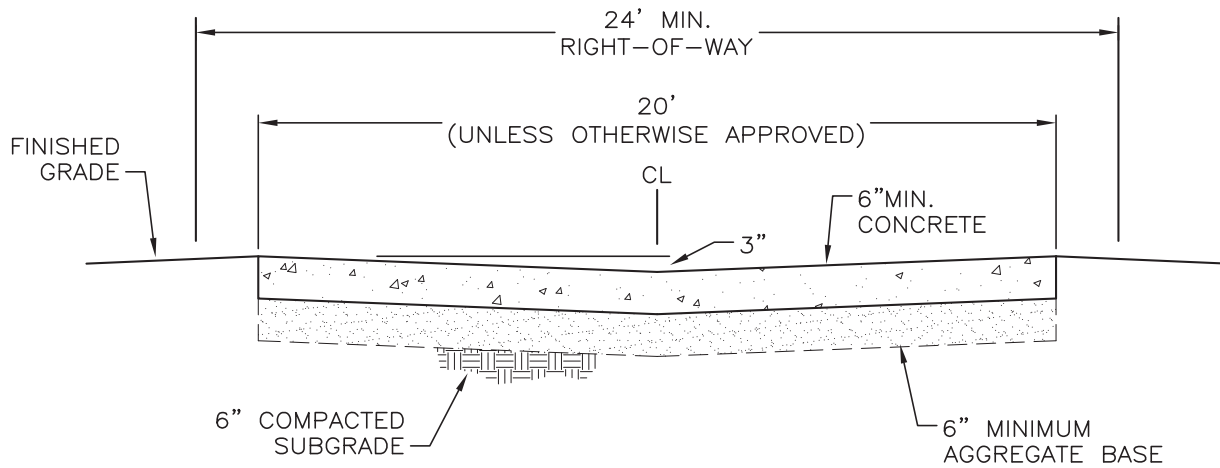

PCC ALLEY SECTION

(SEE DETAIL A10-B FOR PCC ALLEY JOINTING DETAILS)

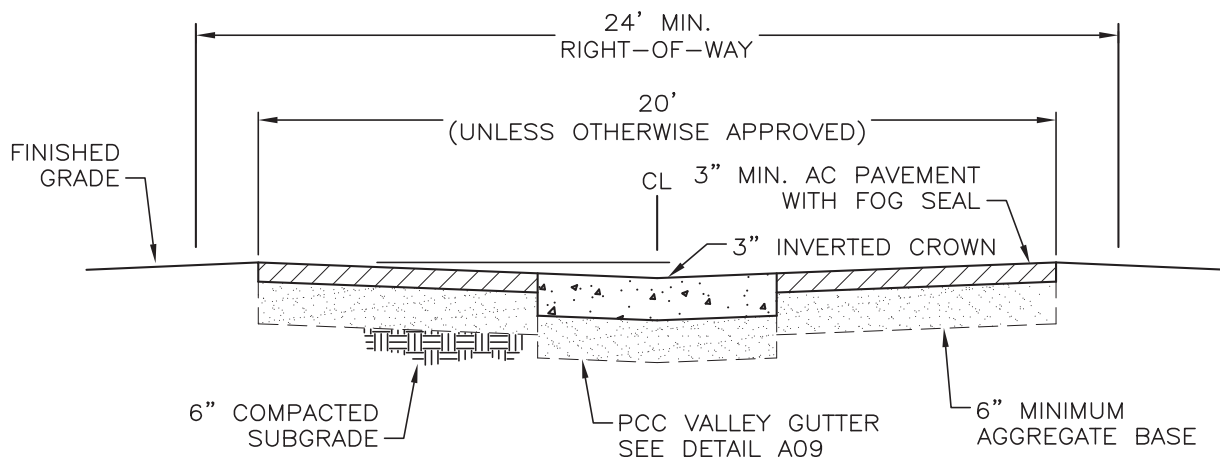

AC ALLEY SECTION

NOTES:

1. SUBGRADE SHALL BE PREPARED IN CONFORMANCE WITH SECTION 302 OF THE STANDARD SPECIFICATIONS FOR PUBLIC WORKS CONSTRUCTION.
2. AGGREGATE BASE SHALL BE TYPE 2, CLASS B AND BE COMPACTED IN CONFORMANCE WITH SECTION 308.05 OF THE STANDARD SPECIFICATIONS FOR PUBLIC WORKS CONSTRUCTION.
3. PORTLAND CEMENT CONCRETE SHALL CONFORM TO THE REQUIREMENTS OF SECTION 337.10.01.01 OF THE STANDARD SPECIFICATIONS FOR PUBLIC WORKS CONSTRUCTION FOR CONCRETE EXPOSED TO FREEZE-THAW ENVIRONMENTS.
4. STRUCTURAL SECTIONS TO BE DETERMINED BY ENGINEERING DESIGN, BUT IN NO CASE LESS THAN THE MINIMUM THICKNESSES SHOWN.

NO.	REVISION	DATE	STANDARD DETAIL FOR PUBLIC WORKS CONSTRUCTION	SECTION: DOUGLAS COUNTY
			TYPICAL ALLEY SECTIONS (PCC & AC)	DATE: JULY 2017
				DWG: A10-A

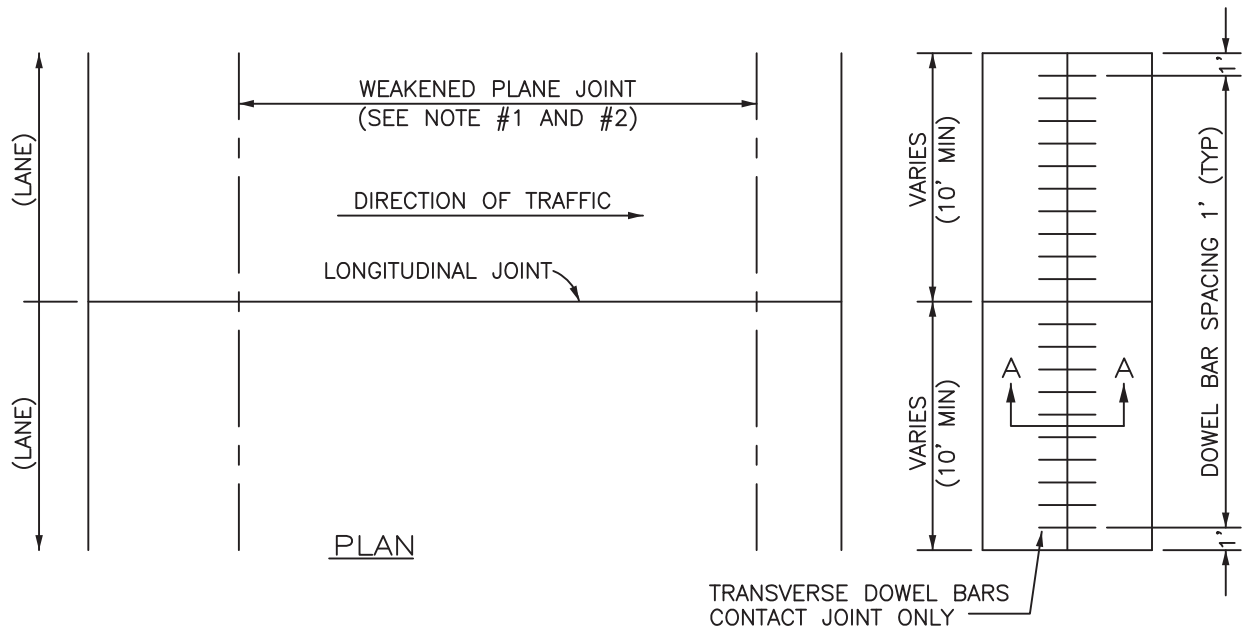

NOTES:

1. SPACING OF WEAKENED PLANE JOINTS SHALL BE 12' MAXIMUM.
2. TRANVERSE WEAKENED PLANE JOINTS SHALL BE CONSTRUCTED AT LEAST 6' FROM ANY TRANSVERSE CONTACT JOINT.
3. LONGITUDINAL WEAKENED PLANE JOINTS SHALL BE CUT AT ALL LANE LINES.
4. STRUCTURAL SECTION TO BE DETERMINED BY ENGINEERING DESIGN, BUT IN NO CASE SHALL THE CONCRETE BE LESS THAN 6" THICK AND THE AGGREGATE BASE LESS THAN 8" THICK.
5. AGGREGATE BASE SHALL BE TYPE 2, CLASS B AND BE CONSTRUCTED IN CONFORMANCE WITH SECTION 308 OF THE STANDARD SPECIFICATIONS FOR PUBLIC WORKS CONSTRUCTION.
6. PORTLAND CEMENT CONCRETE SHALL CONFORM TO THE REQUIREMENTS OF SECTION 202 OF THE STANDARD SPECIFICATIONS FOR PUBLIC WORKS CONSTRUCTION FOR CONCRETE EXPOSED TO FREEZE-THAW ENVIRONMENTS.

NO.	REVISION	DATE	STANDARD DETAIL FOR PUBLIC WORKS CONSTRUCTION	SECTION
			<h1>PCC ALLEY JOINTING DETAILS</h1>	DOUGLAS COUNTY
				DATE: JULY 2017
				DWG: A10-B

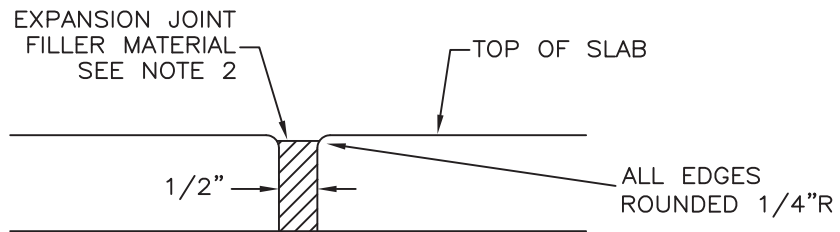

EXPANSION JOINT

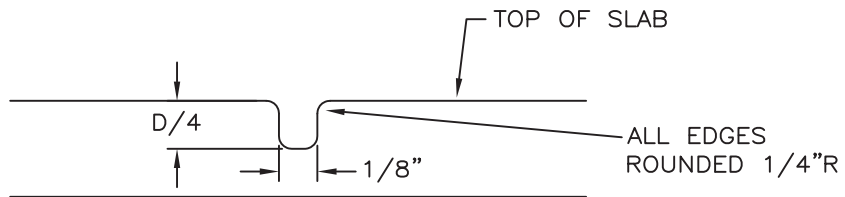

**WEAKENED PLANE JOINT
SIDEWALK, CURB & GUTTER**

ALL MEASUREMENTS: $\pm 1/16$ " TOLERANCE

NOTES:

1. RATIO OF DEPTH TO WIDTH OF JOINT SEALANT SHOULD BE 1:1. INITIAL 1/8-INCH WEAK JOINT SAW CUT TO BE DONE WITHIN SPECIFIED TIME LIMIT. RESERVOIR CUT MAY BE DONE AT A LATER TIME.
2. EXPANSION JOINT FILLER MATERIAL SHALL BE 1/2-INCH BITUMINOUS TYPE PREFORMED EXPANSION JOINT FILLER ASTM D-1751.

NO.	REVISION	DATE	STANDARD DETAIL FOR PUBLIC WORKS CONSTRUCTION	SECTION: DOUGLAS COUNTY
			PCC JOINTING	DATE: JULY 2017
				DWG: A11

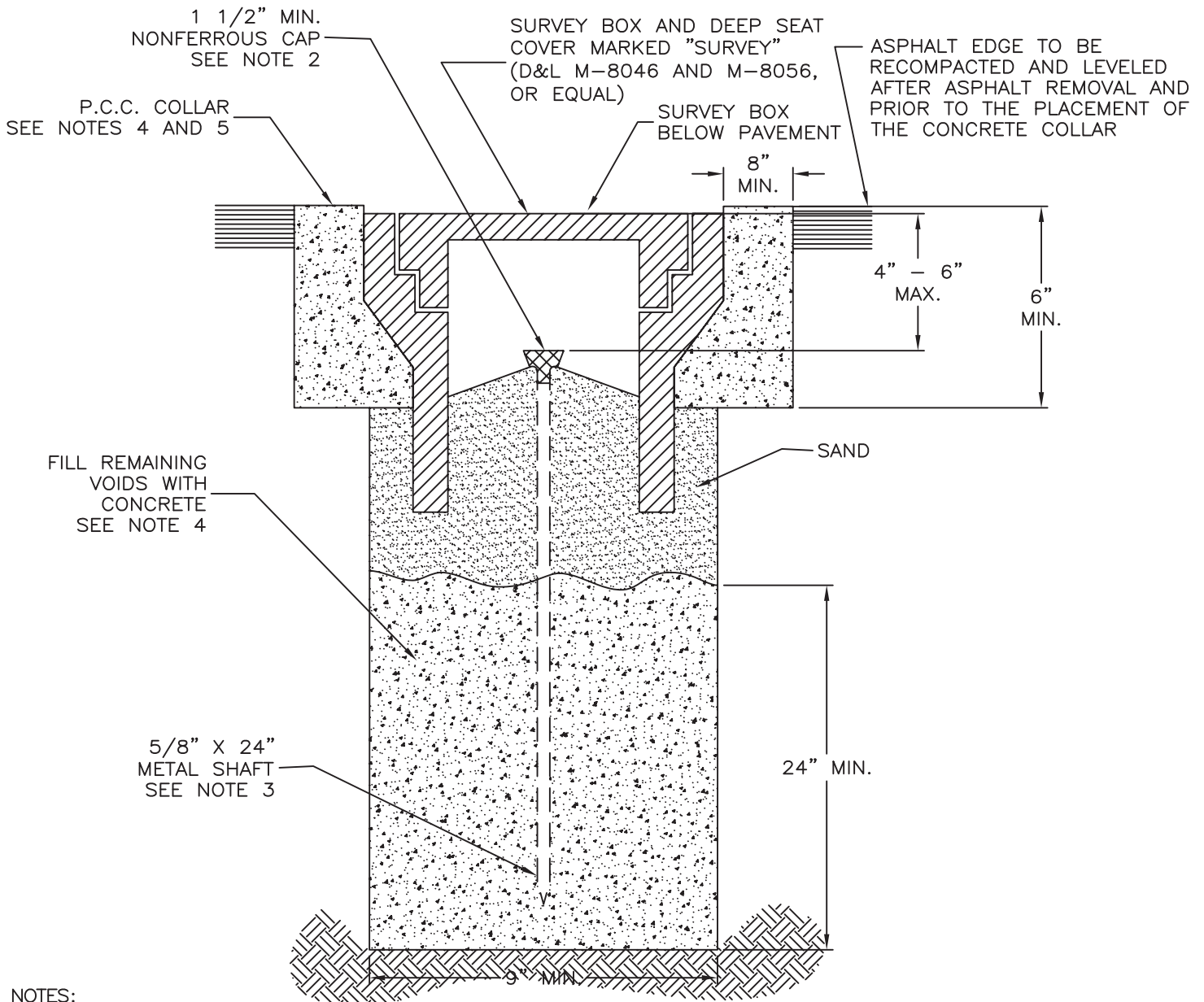

NOTES:

1. FERROUS METAL OVER MONUMENT FOR RECOVERY BY DIP NEEDLE OR MAGNETIC INSERT IN CAP.
2. 1 1/2" MIN. NONFERROUS CAP WITH PROFESSIONAL LAND SURVEYOR NO. PERMANENTLY ATTACHED PRIOR TO PLACEMENT. PRE-PUNCHED CAPS SHALL NOT BE PERMITTED
3. 5/8" METALLIC SHAFT (SMOOTH SHAFTS TO BE DEFORMED).
4. FIBER-REINFORCED PORTLAND CEMENT CONCRETE (P.C.C.) SHALL HAVE THE FOLLOWING CHARACTERISTICS: 4000 PSI MIN. COMPRESSIVE STRENGTH AT 28 DAYS, MIN. 6 SACKS OF CEMENT PER CUBIC YARD WITH MAX. WATER-CEMENT RATIO OF 0.45, AIR ENTRAINMENT 6% ±1.5%, SLUMP AT 1 TO 4 INCHES. MIX DESIGN SHALL CONFORM TO THE REQUIREMENTS OF SECTION 337 OF STANDARD SPECIFICATIONS OF PUBLIC WORKS CONSTRUCTION (SSPWC). CEMENT SHALL BE TYPE II. ALL CEMENT CONCRETE SHALL HAVE A COARSE AGGREGATE GRADATION CONFORMING TO SIZE No. 67. POLYPROPYLENE OR CELLULOSE FIBERS SHALL BE ADDED TO THE P.C.C. AT 1.5 LBS. PER CUBIC YARD. ALL MATERIALS SHALL CONFORM TO SSPWC.
5. P.C.C. COLLARS IN ALL ROADWAYS SHALL BE PROTECTED FROM TRAFFIC LOADS UNTIL MINIMUM 3000 PSI IS ATTAINED.

NO.	REVISION	DATE	STANDARD DETAIL FOR PUBLIC WORKS CONSTRUCTION	SECTION: DOUGLAS COUNTY
			<h1>MONUMENTS</h1>	DATE: JULY 2017
				DWG: A12

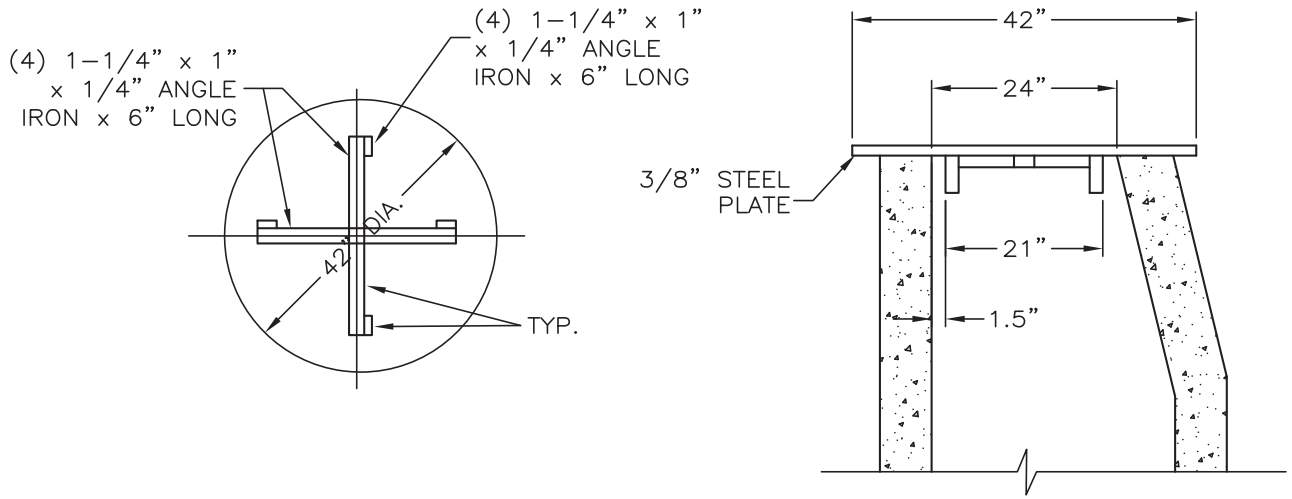

TEMPORARY COVER

NOTES:

1. IN ALL AREAS, COVERS SHALL BE SET 1/4" BELOW FINISHED GRADE UNLESS OTHERWISE NOTED.
2. SOLID, GASKETED MANHOLE LIDS WITH AN INSET GASKET EITHER IN THE FRAME OR THE COVER SHALL BE PROVIDED IN ALL FLOOD PLAIN AREAS AND OTHER AREAS AS REQUIRED BY THE UTILITY.

NO.	REVISION	DATE	STANDARD DETAIL FOR PUBLIC WORKS CONSTRUCTION	SECTION: DOUGLAS COUNTY
			TEMPORARY COVER	DATE: JULY 2017
				DWG: A13

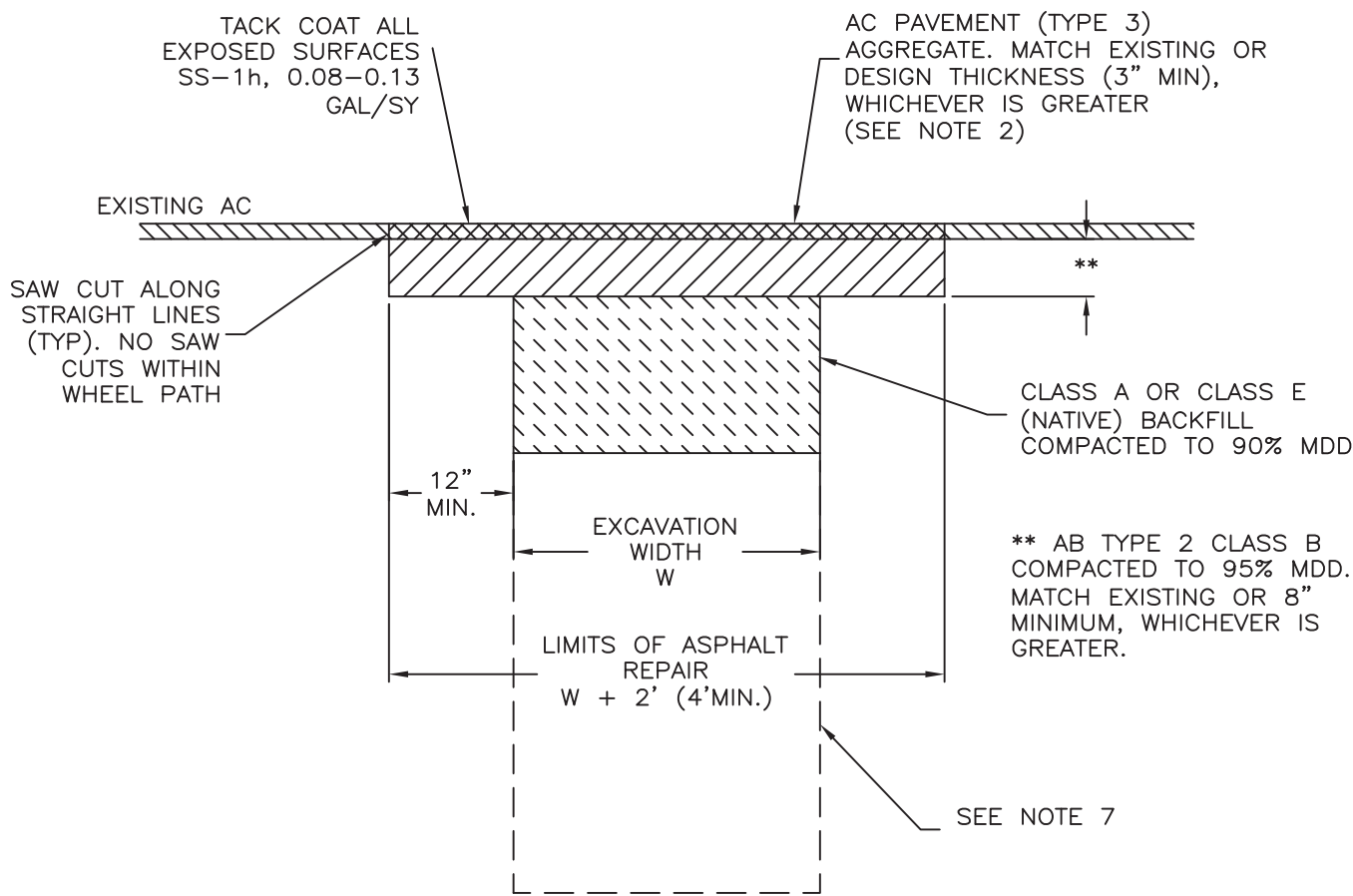

NOTES:

1. BORE AND JACK OR TRENCHLESS DIRECTIONAL DRILLING IS ALLOWED.
2. PATCH WIDTH:
 - A) PATCHES WILL BE 4 FOOT MINIMUM, ANY DIRECTION.
 - B) IF EDGE OF PATCHING IS WITHIN 3 FEET OF EDGE OF PAVEMENT OR LIP OF GUTTER, REMOVE AND REPLACE AC PAVEMENT FROM PATCH TO THAT EDGE.
 - C) FOR PATCHING IN PAVEMENT SURFACE THAT IS LESS THAN FIVE (5) YEARS OLD OR PCI>80, ENTIRE TRAVEL LANE WIDTH FOR FULL LENGTH OF PAVEMENT PATCH SHALL RECEIVE 1.5" MILL AND OVERLAY.
 - D) PLACE SLURRY SEAL OR CHIP SEAL ON STREETS WITH EXISTING SLURRY SEAL OR CHIP SEAL SURFACE.
3. SURFACE TOLERANCES FOR AC PAVEMENT REPAIR SHALL CONFORM TO THE CURRENT EDITION OF THE STANDARD SPECIFICATIONS FOR PUBLIC WORKS CONSTRUCTION (ORANGE BOOK).
4. ASPHALT CONCRETE CONSTRUCTION MATERIALS AND TESTING SHALL CONFORM TO THE STANDARD SPECIFICATIONS FOR PUBLIC WORKS CONSTRUCTION (ORANGE BOOK).
5. TYPE 2 CLASS B AGGREGATE BASE SHALL CONFORM TO THE STANDARD SPECIFICATIONS FOR PUBLIC WORKS CONSTRUCTION (ORANGE BOOK).
6. ASPHALT CEMENT SHALL BE PG 64-28 NV UNLESS OTHERWISE APPROVED BY DOUGLAS COUNTY ENGINEERING. WHEN PG 64-28 NV ASPHALT CEMENT IS NOT USED, NEW ASPHALT CONCRETE SURFACE SHALL BE FOG SEALED.
7. FOR NON-COUNTY UTILITIES, PIPE ZONE BEDDING PER UTILITY PURVEYOR REQUIREMENTS. BACKFILL PER COUNTY REQUIREMENTS.

NO.	REVISION	DATE	STANDARD DETAIL FOR PUBLIC WORKS CONSTRUCTION	SECTION: DOUGLAS COUNTY
			STREET CUT REPAIR	DATE: JULY 2017
				DWG: A14

SOUTH & WEST

NORTH & EAST

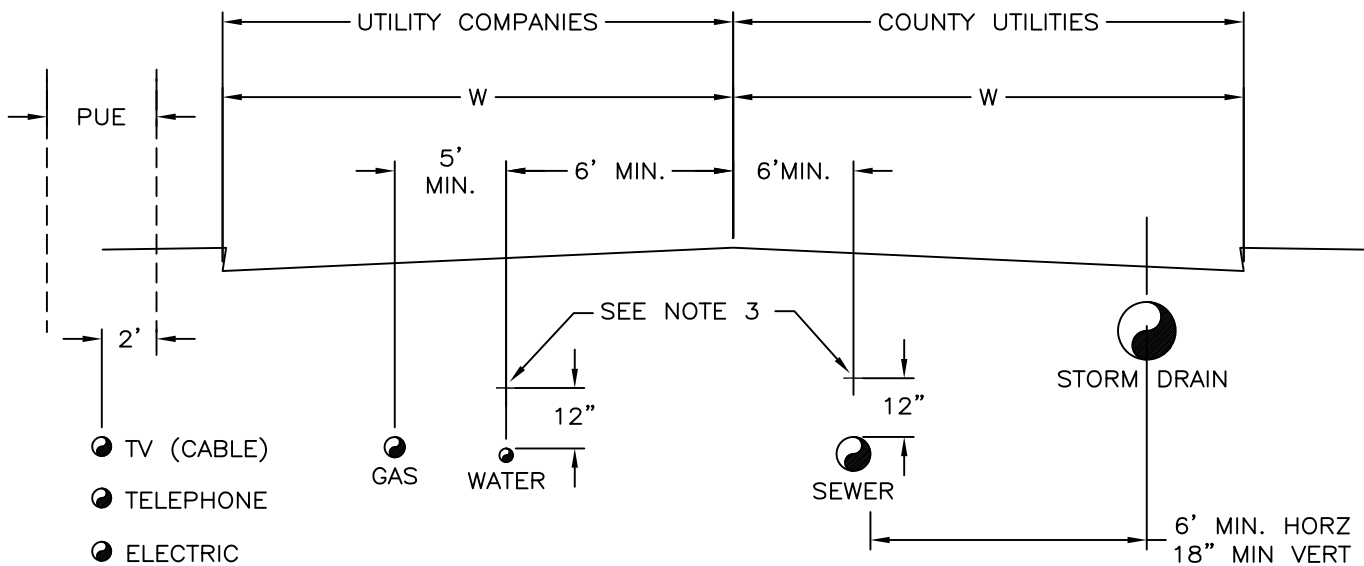

TYPICAL SECTION "B"

APPROXIMATE DEPTH OF COVER	
STORM DRAIN	24"
SANITARY SEWER	72"
WATER MAIN	42"
GAS MAIN	30" *
TV (CABLE), TELEPHONE	30"-48" *
ELECTRICITY	56"-72" *
STREET LIGHTING	30"

* OR LOCAL UTILITY STANDARDS

NOTES:

1. MIN. DEPTH DOES NOT APPLY TO MGSD SEWER LINES. DEAD END LINES ON CUL-DE-SACS MAY BE SHALLOWER.
2. FOR STORM DRAIN, STANDARD 24", IF SHALLOW OUTFALL CONDITION EXISTS. STORM DRAIN MAY BE MORE SHALLOW, BUT UNDER NO CIRCUMSTANCES SHALL PIPE BE LOCATED WITHIN BASE SECTION.
3. FOR TRENCH EXCAVATION AND BACKFILL SEE APPLICABLE APPENDIX.
4. P.U.E. INDICATES PUBLIC UTILITY EASEMENT.
5. PLACE LOCATION TAPE 1 FOOT ABOVE WATER, AND SEWER PIPE. IN ADDITION TO LOCATION TAPE, PLACE LOCATOR WIRE ON WATER, AND SANITARY SEWER FORCE MAINS.
6. DEPTHS OF COVER AND LOCATION OTHER THAN THOSE SHOWN ABOVE ARE SUBJECT TO COUNTY ENGINEER APPROVAL. NDEP'S "VERTICAL CROSSING CONFLICTS SUMMARY", AND NAC 445 SHALL BE MET AS MINIMUM.
7. MAINTAIN 10 FOOT HORIZONTAL SEPARATION BETWEEN OUTER DIAMETER OF SEWER AND WATER PIPE.
8. VALVE CANS AND MANHOLES SHALL BE CENTERED IN THE LANE BETWEEN THE WHEEL PATH.

NO.	REVISION	DATE	STANDARD DETAIL FOR PUBLIC WORKS CONSTRUCTION	SECTION: DOUGLAS COUNTY
			TYPICAL UTILITY MAIN LOCATIONS	DATE: DEC. 2018
				DWG: A15

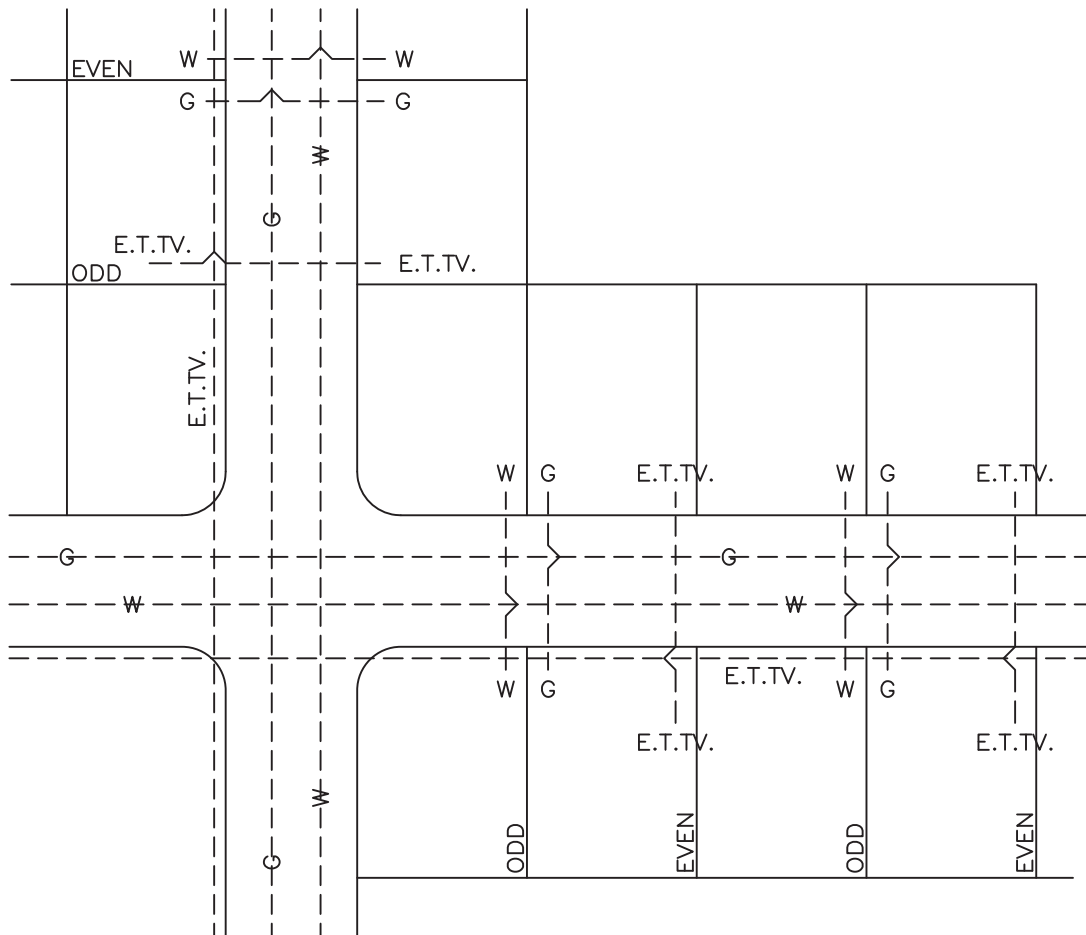

UTILITY LOCATION

NOTES:

1. SANITARY SEWER LATERAL TO BE INSTALLED A MINIMUM 4' DISTANCE FROM WATER LATERAL AND MEET REQUIREMENTS OF NAC 445A AS APPLICABLE.
2. COMMON LOT CORNERS ARE DEFINED AS ODD OR EVEN AS COUNTED NORTH OR EAST FROM THE PRECEDING STREET INTERSECTION.
3. WATER SERVICES SHALL BE PLACED ON ODD LOT CORNERS ON EAST-WEST STREETS AND ON EVEN LOT CORNERS ON NORTH-SOUTH STREETS. ADDITIONALLY, WATER SERVICES SHALL BE ONE FOOT WEST OR NORTH OF THE RESPECTIVE LOT LINE (SEE SKETCH).
4. GAS SERVICES SHALL BE PLACED ON THE SAME LOT CORNERS AS THE WATER DESCRIBED ABOVE, EXCEPT THAT IT SHALL BE 4 FEET EAST OR SOUTH OF THE RESPECTIVE LOT LINE (OPPOSITE SIDE OF WATER) (SEE SKETCH).
5. ELECTRICITY, TELEPHONE AND CABLE TV SHALL BE PLACED ON EVEN LOT CORNER ON EAST-WEST STREETS AND ON ODD LOT CORNERS ON NORTH-SOUTH STREETS.
6. FOR MAIN LOCATION SEE "TYPICAL UTILITY MAIN LOCATIONS" DETAIL A15.

NO.	REVISION	DATE	STANDARD DETAIL FOR PUBLIC WORKS CONSTRUCTION	SECTION: DOUGLAS COUNTY
			TYPICAL UTILITY LATERALS LOCATIONS	DATE: JULY 2017
				DWG: A16

THROUGH ROAD SPEED M.P.H.	D1 (FEET)	
	$n v_c v_m \leq 4000$	$n v_c v_m > 4000$
≤ 40	70	200

THROUGH ROAD SPEED M.P.H.	D2 (FEET)		
	$\frac{v_c}{1.5N-.5} \leq 50$	$50 < \frac{v_c}{1.5N-.5} \leq 400$	$\frac{v_c}{1.5N-.5} > 400$
≤ 40	70	100	100

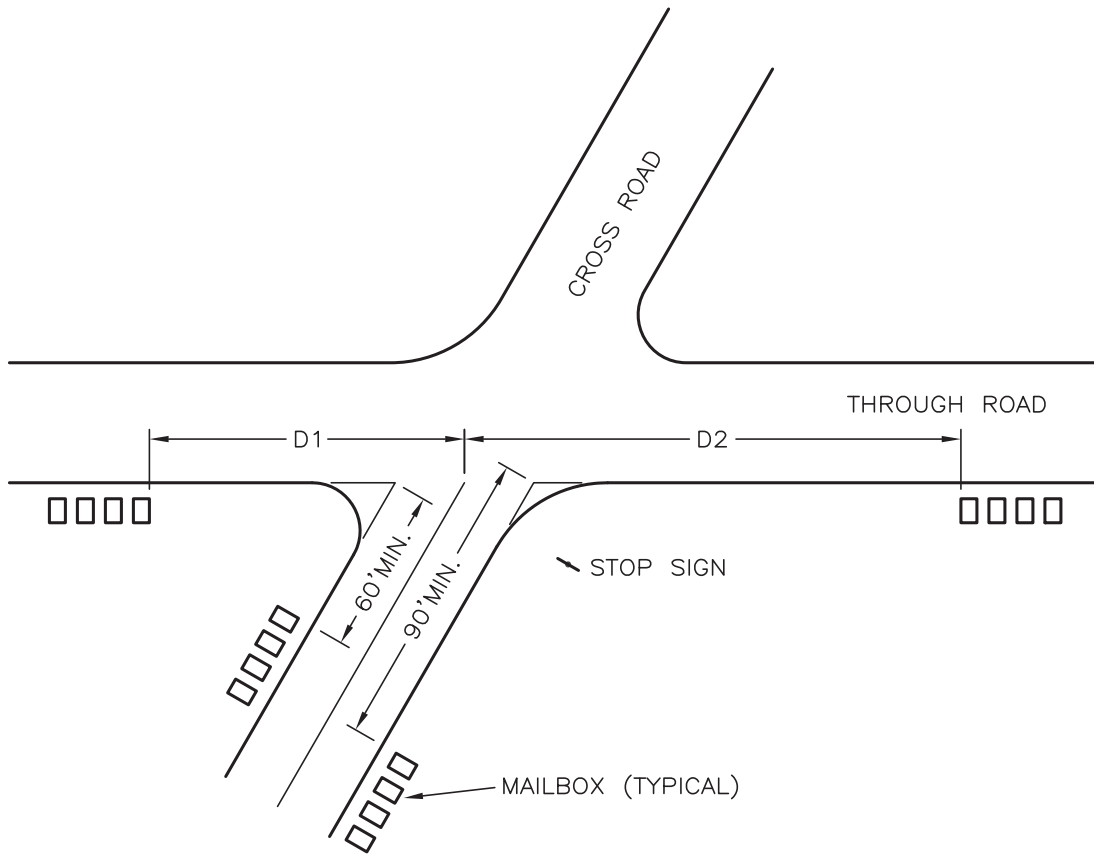

- v_c AVERAGE DAILY TRAFFIC ON
CROSS ROAD VEHICLES PER DAY
- v_m AVERAGE DAILY TRAFFIC ON
THROUGH ROAD VEHICLES PER DAY
- n NUMBER OF MAILBOXES AT MAIL STOP

**MINIMUM CLEARANCE DISTANCES
TO NEAREST CLUSTER BOX IN
MAIL STOPS AT INTERSECTIONS**

SEE NOTES ON PAGE 2

NO.	REVISION	DATE	STANDARD DETAIL FOR PUBLIC WORKS CONSTRUCTION	SECTION: DOUGLAS COUNTY
			CLUSTER BOX TURNOUTS	DATE: JULY 2017
				DWG: A17

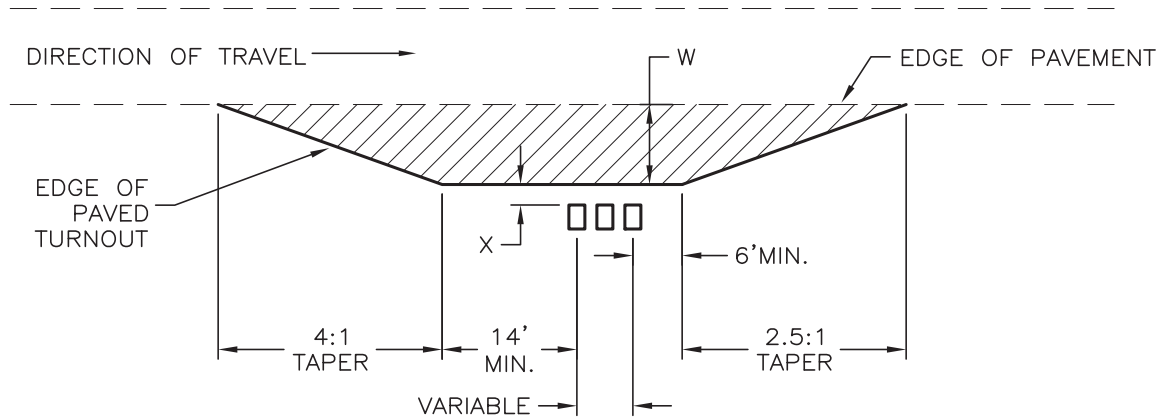

W = SEE TABLE 1 FOR WIDTHS

X = SEE TABLE 1 FOR MAILBOX FACE OFFSET (0" - 24")

**CLUSTER BOX TURNOUT
(For Speeds < 40 MPH)**

TABLE 1

ROADWAY TYPE AND TRAFFIC CONDITIONS	WIDTH (W) OF ALL-WEATHER SURFACE OF TURNOUT OR AVAILABLE SHOULDER AT MAILBOX	DISTANCE (X) ROADSIDE FACE OF CLUSTER BOX IS TO BE OFFSET BEHIND EDGE OF TURNOUT OR USABLE SHOULDER
	MINIMUM (FEET)	MINIMUM (FEET)
RURAL ROAD	14'	0'
RESIDENTIAL STREET W/O CURB	12'	2'
RESIDENTIAL STREET WITH CURB	N/A	2' (BEHIND BACK OF SIDEWALK)

NOTES:

1. WHERE POSSIBLE, CLUSTER BOX SHALL BE LOCATED ON NORTH SIDE OF STREET, AS APPROVED BY USPS.
2. AN 8-FOOT TALL PEDESTRIAN LIGHT SHALL BE PROVIDED AS NEEDED. COMMUNITY DEVELOPMENT DIRECTOR OR TOWN SHALL APPROVE LIGHT FIXTURE.

NO.	REVISION	DATE	CLUSTER BOX TURNOUTS	SECTION:
				DOUGLAS COUNTY
				DATE: JULY 2017
				DWG: A17

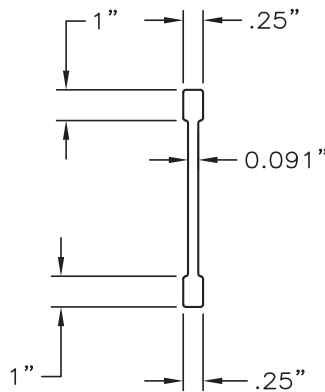
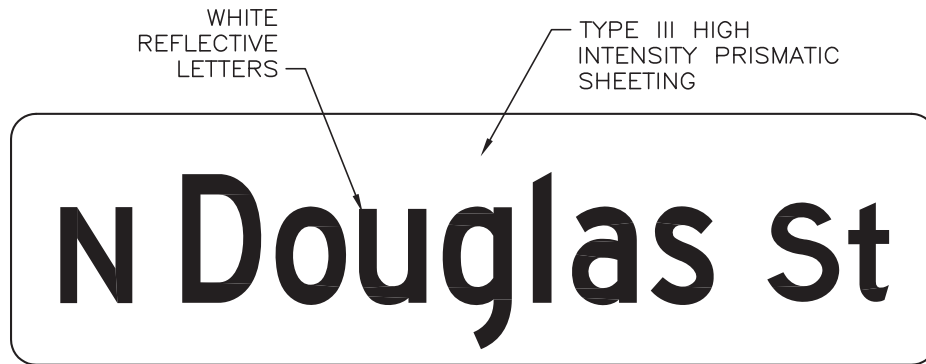

NOTES:

1. STREET NAME SIGN, DIMENSIONING, AND LETTERING SHALL BE IN COMPLIANCE SIGN TYPE D3-1 WITHOUT BORDER, WITH THE LATEST EDITION OF THE MUTCD AND STANDARD HIGHWAY SIGNS MANUAL.
2. SIGN PANEL SHALL BE HEAVY DUTY EXTRUDED ALUMINUM 6061-T6.
3. REFLECTIVE SHEETING AND LETTERS SHALL BE MOUNTED IN CONFORMANCE WITH SECTION 215 OF THE STANDARD SPECIFICATIONS FOR PUBLIC WORKS CONSTRUCTION.
4. MOUNT SIGN IN MINIMUM 12 INCH LONG EXTRUDED BLADE BRACKET.
5. FOR PRIVATE STREETS THAT INTERSECT WITH A PUBLIC ROAD, AN ADDITIONAL TRAFFIC SIGN SHALL BE INCLUDED THAT READS: "PRIVATE STREET NOT MAINTAINED BY COUNTY".

NO.	REVISION	DATE	STANDARD DETAIL FOR PUBLIC WORKS CONSTRUCTION	SECTION: DOUGLAS COUNTY
			STREET NAME SIGN	DATE: JULY 2017
				DWG: A18-A

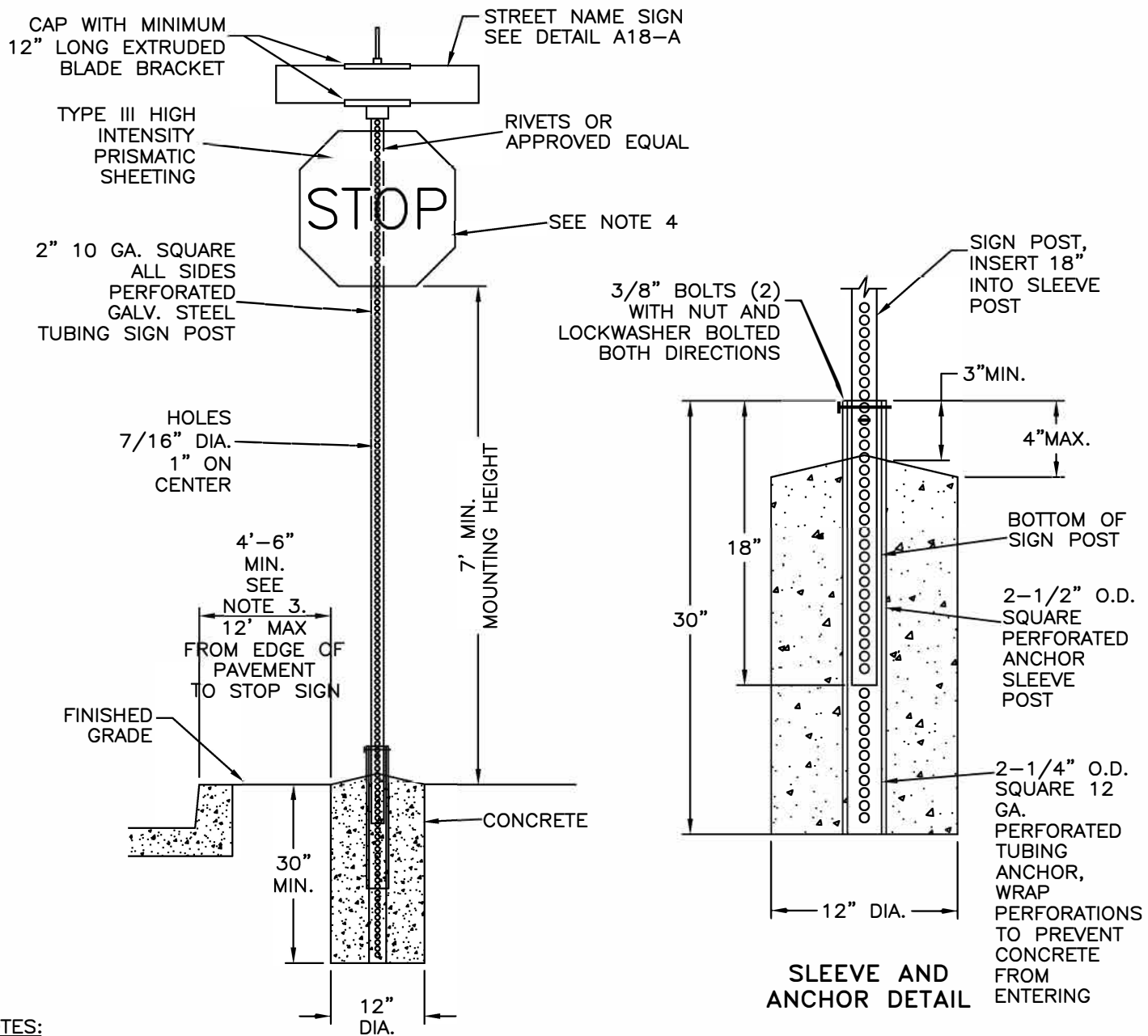

NOTES:

1. SIGN MATERIALS, CONSTRUCTION AND PLACEMENT SHALL BE IN CONFORMANCE WITH THE LATEST EDITION OF THE MANUAL ON UNIFORM TRAFFIC CONTROL DEVICES AND SECTION 215 OF THE STANDARD SPECIFICATIONS FOR PUBLIC WORKS CONSTRUCTION.
2. STREET NAME SIGN SHALL BE MOUNTED WITH VANDAL-RESISTANT HARDWARE.
3. ON STREETS WHERE CURB DOES NOT EXIST, SET EDGE OF SIGN 6' MINIMUM FROM PAVEMENT EDGE.
4. SIGN (WITH 3/8" GALVANIZED STEEL BACK BRACE) AND LETTERING SHALL BE IN CONFORMANCE WITH THE LATEST EDITION OF THE MUTCD.
5. SIGN POST SHALL NOT BE ANCHORED IN SIDEWALK.
6. POSTS AND ANCHORS IN THE DOWNTOWN AREA OF GARDNERVILLE SHALL BE BLACK.
7. DECORATIVE POLES AND SIGNS MAY BE REQUIRED IN THE TOWNS OF MINDEN AND GARDNERVILLE. REFER TO THE TOWN'S SPECIFIC DETAILS.

NO.	REVISION	DATE	STANDARD DETAIL FOR PUBLIC WORKS CONSTRUCTION	SECTION:
			STANDARD STREET SIGN	DOUGLAS COUNTY
				DATE:
				DEC. 2018
				DWG:
				A18-B

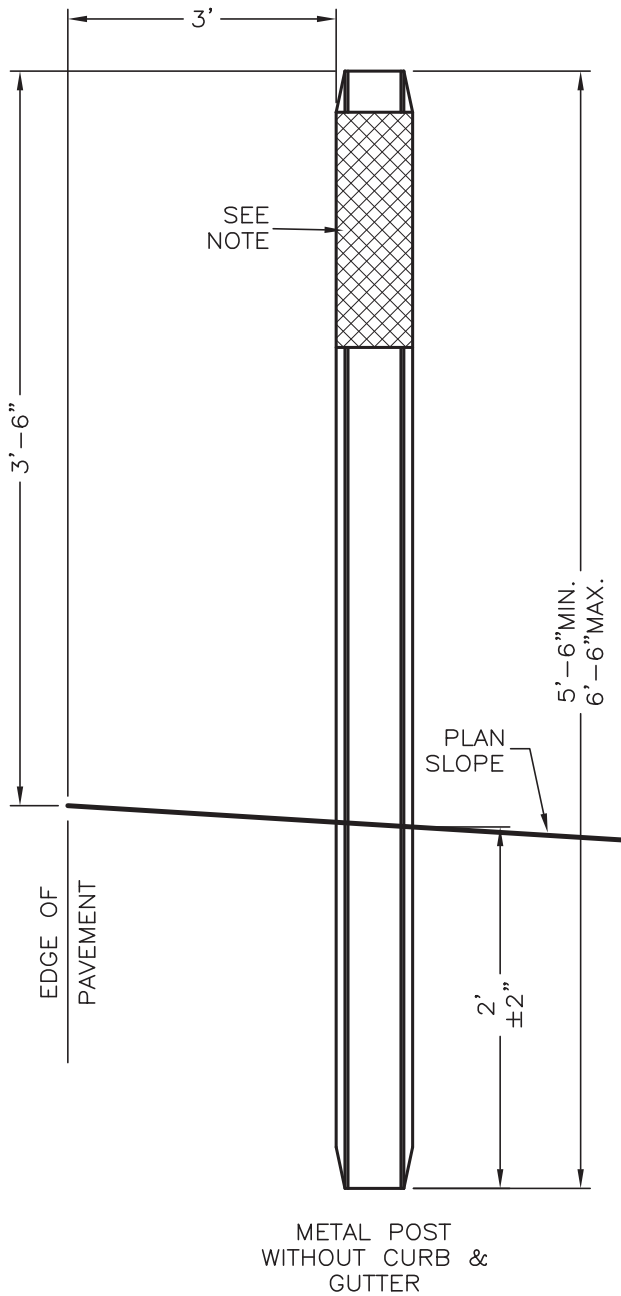

TYPICAL INSTALLATION

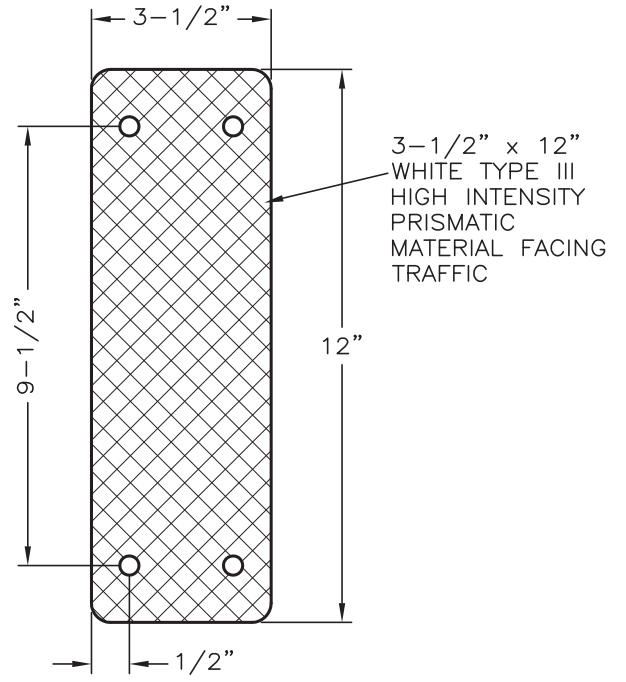

METAL POST REFLECTOR

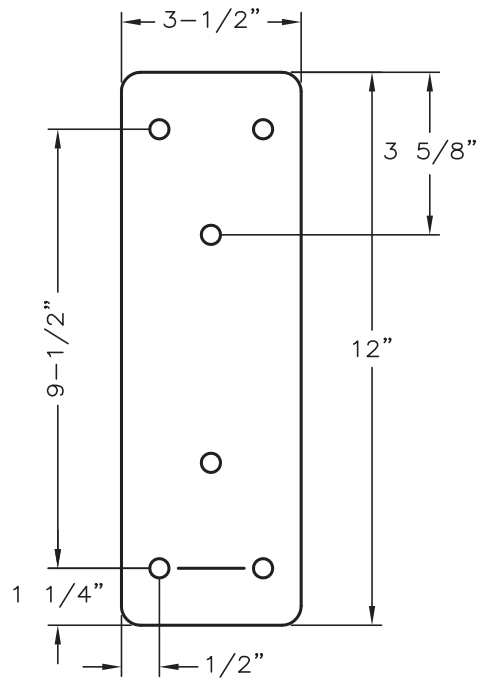

METAL PLATE W/0.38" HOLES

NOTES:

1. TYPE OF REFLECTORS ACCORDING TO LOCATION. COLOR TO MATCH ADJACENT EDGE LINE.
2. 11 GAUGE POST.

NO.	REVISION	DATE	STANDARD DETAIL FOR PUBLIC WORKS CONSTRUCTION	SECTION: DOUGLAS COUNTY
			GUIDE POST	DATE: JULY 2017
				DWG: A19

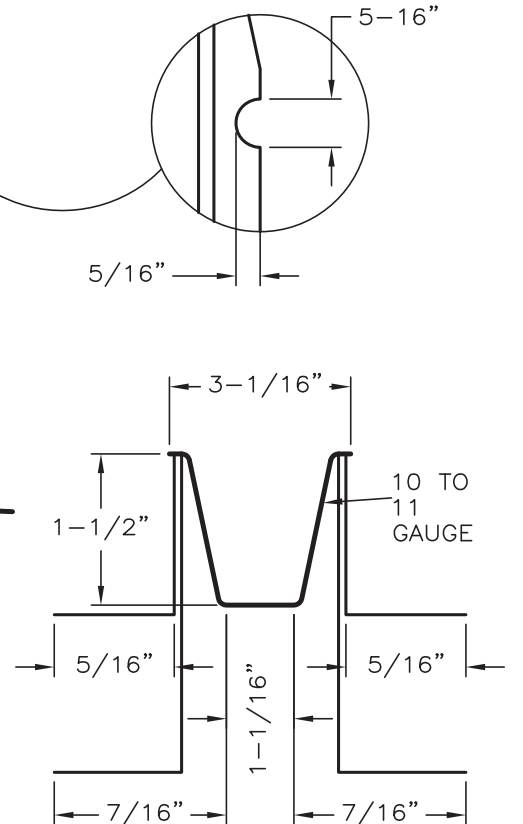
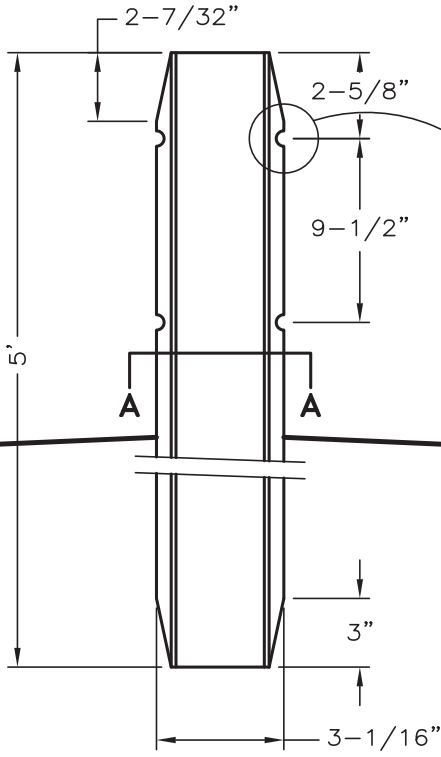
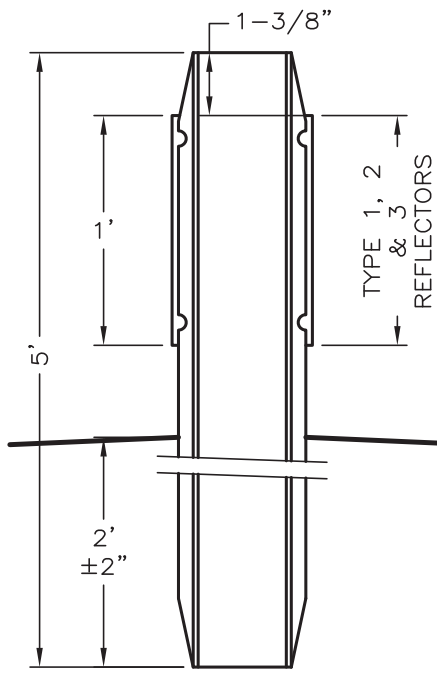

METAL POST DETAILS

SECTION A-A

APPROXIMATE SPACING FOR DELINEATORS ON HORIZONTAL CURVES

RADIUS (R) OF CURVE	APPROXIMATE SPACING (S) ON CURVE
50 FEET	20 FEET
115 FEET	25 FEET
180 FEET	35 FEET
250 FEET	40 FEET
300 FEET	50 FEET
400 FEET	55 FEET
500 FEET	65 FEET
600 FEET	70 FEET
700 FEET	75 FEET
800 FEET	80 FEET
900 FEET	85 FEET
1000 FEET	90 FEET

NOTES:

1. SPACING FOR SPECIFIC RADII MAY BE INTERPOLATED FROM TABLE.
2. THE MINIMUM SPACING SHOULD BE 20 FEET.
3. THE SPACING ON CURVES SHOULD NOT EXCEED 300 FEET.
4. IN ADVANCE OF OR BEYOND A CURVE, AND PROCEEDING AWAY FROM THE END OF THE CURVE, THE SPACING OF THE FIRST DELINEATOR IS 2S, THE SECOND 3S, AND THE THIRD 6S, BUT NOT TO EXCEED 300 FEET.
5. S REFERS TO THE DELINEATOR SPACING FOR SPECIFIC RADII COMPUTED FROM THE FORMULA $S=3\sqrt{R-50}$.
6. THE DISTANCES FOR S SHOWN IN THE TABLE ABOVE WERE ROUNDED TO THE NEAREST 5 FEET.
7. DELINEATORS ARE NOT REQUIRED FOR LOCAL URBAN ROADWAYS.
8. MAXIMUM SPACING ON TANGENTS IS 530 FEET.
9. REFER TO THE CURRENT EDITION OF THE MUTCD FOR ADDITIONAL GUIDANCE.

NO.	REVISION	DATE	STANDARD DETAIL FOR PUBLIC WORKS CONSTRUCTION	SECTION: DOUGLAS COUNTY
			GUIDE POST	DATE: JULY 2017
				DWG: A19

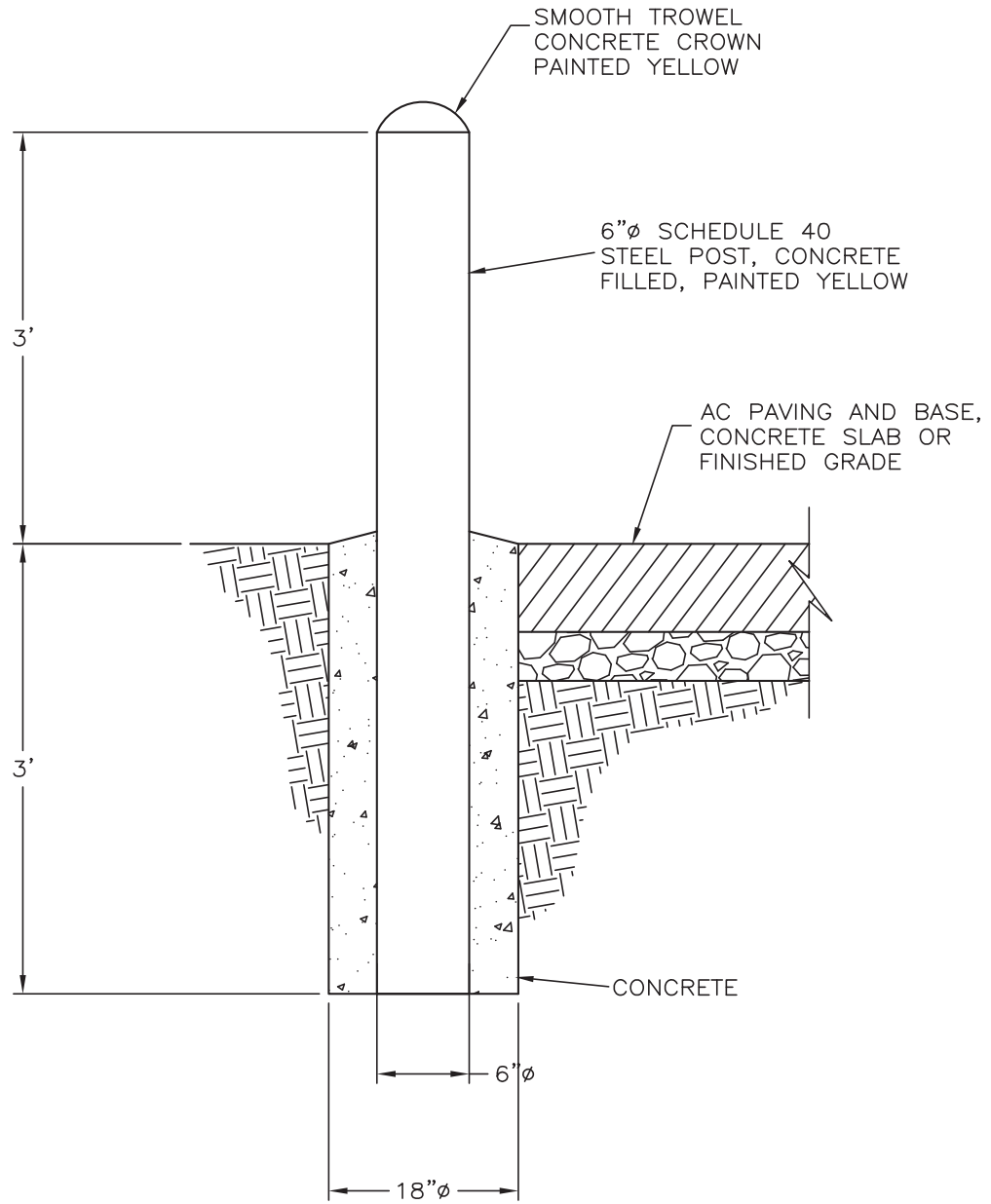

NO.	REVISION	DATE	STANDARD DETAIL FOR PUBLIC WORKS CONSTRUCTION	SECTION: DOUGLAS COUNTY
			<h1>BOLLARD</h1>	DATE: JULY 2017
				DWG: A20

POLE TYPE	B (INCHES)	BC (INCHES)
7	1-1/4"	11
14	1-3/4"	12

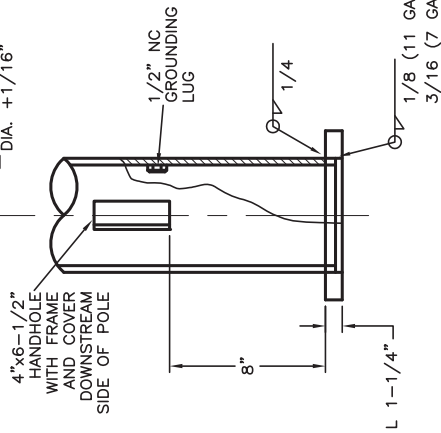
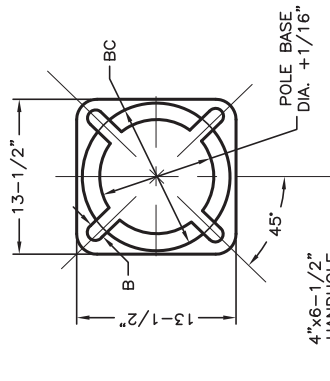

DETAIL A
BASE PLATE
(NOT APPLICABLE WHEN
SAFETY BASES ARE REQUIRED)

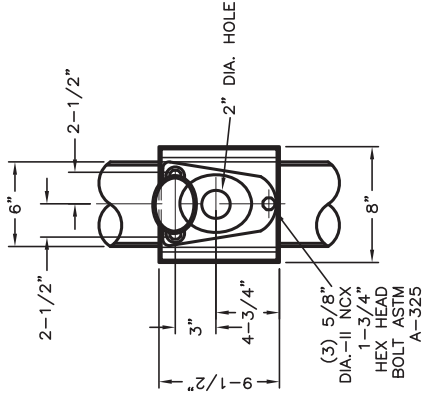
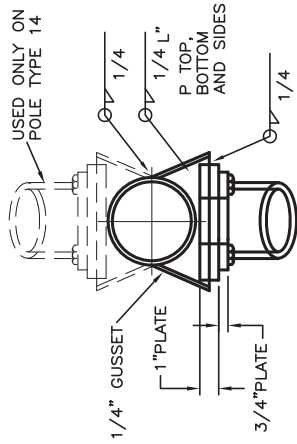

DETAIL C
LUMINAIRE TENON CONNECTION

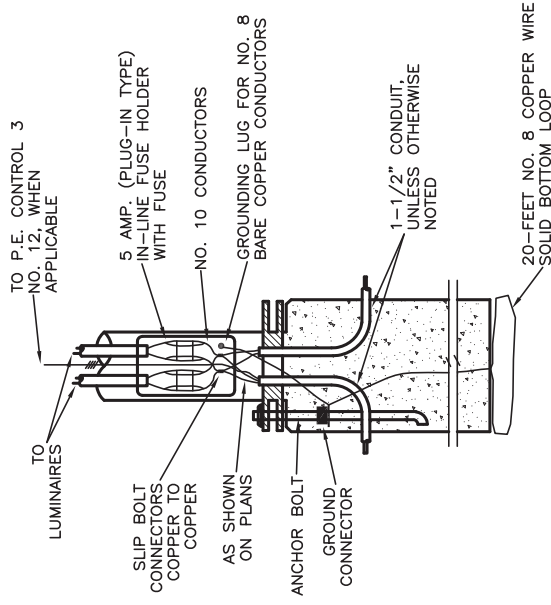

**WIRING DIAGRAM FOR
POLE TYPE 7 & TYPE 14**

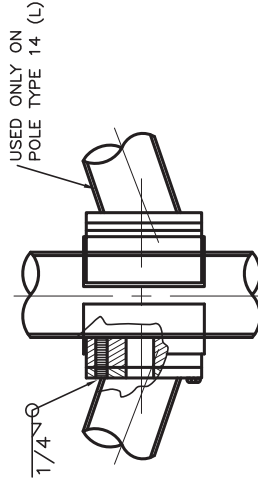

DETAIL E
LUMINAIRE TENON DETAIL

NO. REVISION DATE STANDARD DETAIL FOR PUBLIC WORKS CONSTRUCTION

SECTION:

DOUGLAS COUNTY

DATE: JULY 2017

DWG: A21-A

**TYPE 7 & 14 POLE
LIGHTING & SIGNAL**

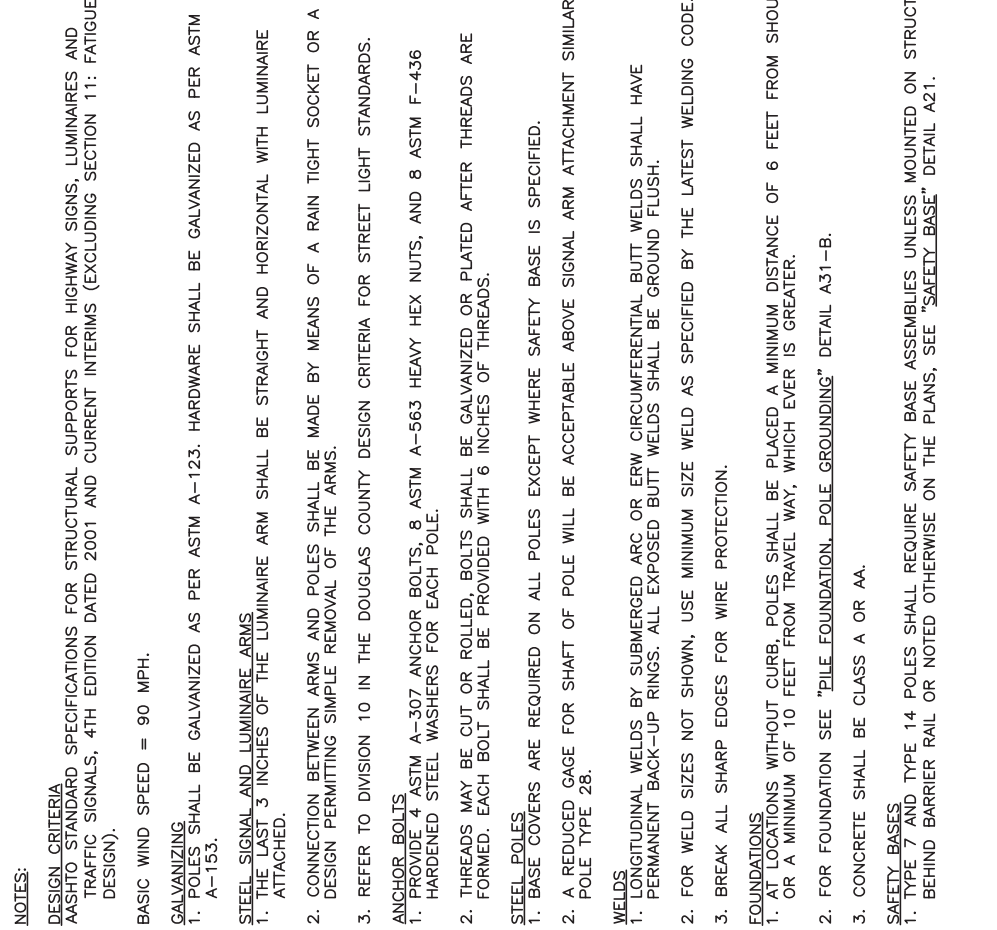

POLE TYPE 7

POLE TYPE 14

NOTES:

DESIGN CRITERIA
 AASHTO STANDARD SPECIFICATIONS FOR STRUCTURAL SUPPORTS FOR HIGHWAY SIGNS, LUMINAIRES AND TRAFFIC SIGNALS, 4TH EDITION DATED 2001 AND CURRENT INTERIMS (EXCLUDING SECTION 11: FATIGUE DESIGN).
 BASIC WIND SPEED = 90 MPH.

GALVANIZING
 1. POLES SHALL BE GALVANIZED AS PER ASTM A-123. HARDWARE SHALL BE GALVANIZED AS PER ASTM A-153.

STEEL SIGNAL AND LUMINAIRE ARMS
 1. THE LAST 3 INCHES OF THE LUMINAIRE ARM SHALL BE STRAIGHT AND HORIZONTAL WITH LUMINAIRE ATTACHED.

2. CONNECTION BETWEEN ARMS AND POLES SHALL BE MADE BY MEANS OF A RAIN TIGHT SOCKET OR A DESIGN PERMITTING SIMPLE REMOVAL OF THE ARMS.

3. REFER TO DIVISION 10 IN THE DOUGLAS COUNTY DESIGN CRITERIA FOR STREET LIGHT STANDARDS.

ANCHOR BOLTS
 1. PROVIDE 4 ASTM A-307 ANCHOR BOLTS, 8 ASTM A-563 HEAVY HEX NUTS, AND 8 ASTM F-436 HARDENED STEEL WASHERS FOR EACH POLE.

2. THREADS MAY BE CUT OR ROLLED, BOLTS SHALL BE GALVANIZED OR PLATED AFTER THREADS ARE FORMED. EACH BOLT SHALL BE PROVIDED WITH 6 INCHES OF THREADS.

STEEL POLES
 1. BASE COVERS ARE REQUIRED ON ALL POLES EXCEPT WHERE SAFETY BASE IS SPECIFIED.
 2. A REDUCED GAGE FOR SHAFT OF POLE WILL BE ACCEPTABLE ABOVE SIGNAL ARM ATTACHMENT SIMILAR TO POLE TYPE 28.

WELDS
 1. LONGITUDINAL WELDS BY SUBMERGED ARC OR ERW CIRCUMFERENTIAL BUTT WELDS SHALL HAVE PERMANENT BACK-UP RINGS. ALL EXPOSED BUTT WELDS SHALL BE GROUND FLUSH.
 2. FOR WELD SIZES NOT SHOWN, USE MINIMUM SIZE WELD AS SPECIFIED BY THE LATEST WELDING CODE.
 3. BREAK ALL SHARP EDGES FOR WIRE PROTECTION.

FOUNDATIONS
 1. AT LOCATIONS WITHOUT CURB, POLES SHALL BE PLACED A MINIMUM DISTANCE OF 6 FEET FROM SHOULDER OR A MINIMUM OF 10 FEET FROM TRAVEL WAY, WHICH EVER IS GREATER.
 2. FOR FOUNDATION SEE "PILE FOUNDATION, POLE GROUNDING" DETAIL A31-B.
 3. CONCRETE SHALL BE CLASS A OR AA.

SAFETY BASES
 1. TYPE 7 AND TYPE 14 POLES SHALL REQUIRE SAFETY BASE ASSEMBLIES UNLESS MOUNTED ON STRUCTURE BEHIND BARRIER RAIL OR NOTED OTHERWISE ON THE PLANS, SEE "SAFETY BASE" DETAIL A21.

STANDARD DETAIL FOR PUBLIC WORKS CONSTRUCTION

SECTION:
DOUGLAS COUNTY

DATE:
JULY 2017

DWG:
A21-A

TYPE 7 & 14 POLE LIGHTING & SIGNAL

NO.	REVISION	DATE

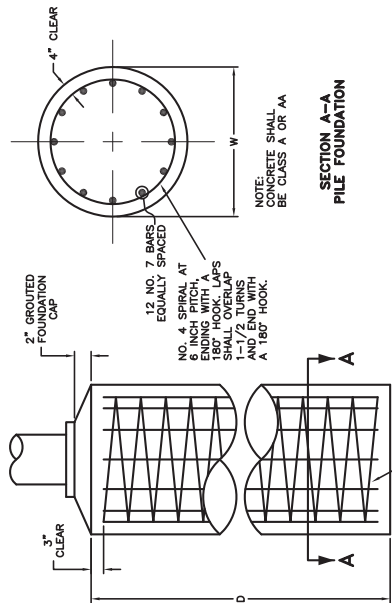

POLE TYPE	MAST ARM LENGTH	D **	W **	ANCHOR BOLTS (4 EACH)
1A & 1B	N/A	3'	2'	3/4" x 18" x 4"
7	ALL	5'	2'-6"	* 1" x 36" x 4"
14	ALL	5'	2'-6"	* 1" x 48" x 4"
28	ALL	12'	3'	2" x 66" x 6"
30 & 35	≤45	12'	3'	1-3/4" x 60" x 6"
30A & 35A	≤60	12'	3'	2" x 66" x 6"

** UNLESS OTHERWISE SHOWN ON PLANS
 * NOT APPLICABLE WHEN MOUNTED ON STRUCTURES
 (1) WHEN W = 2'-0" USE (4) NO. 5 BARS EQUALLY SPACED
 WHEN W = 2'-6" USE (8) NO. 5 BARS EQUALLY SPACED

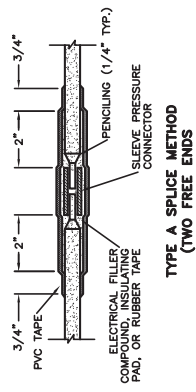

1. COMPLETELY COVER THE SPLICE AREA WITH AN ELECTRICAL INSULATING COATING AND ALLOW TO DRY.
2. APPLY ELECTRICAL FILLER COMPOUND WITH MINIMUM THICKNESS OF 1/8".
3. APPLY 3 LAYERS OF HALF LAPPED PVC TAPE.

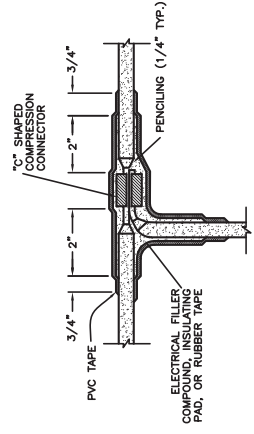

1. COMPLETELY COVER THE SPLICE AREA WITH AN ELECTRICAL INSULATING COATING AND ALLOW TO DRY.
2. APPLY 2 LAYERS OF ELECTRICAL INSULATING PAD WITH MINIMUM THICKNESS OF 1/8" EACH LAYER OR 2 LAYERS, HALF LAPPED, SYNTHETIC OIL RESISTANT, SELF FUSING RUBBER TAPE.
3. APPLY 3 LAYERS OF HALF LAPPED PVC TAPE.

CONDUCTOR SPLICING METHODS

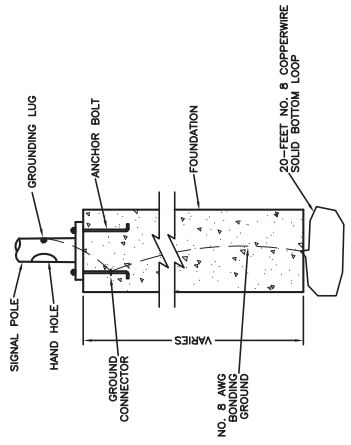

1. CONNECT BONDING WIRE TO THE REINFORCIN STEEL CASE NEAR THE MIDPOINT OF THE FOUNDATION OR ANCHOR BOLTS.

POLE GROUNDING DETAIL

- NOTES:**
1. ALL DIMENSIONS ARE MINIMAL.
 2. RUBBER TAPES SHALL BE ROLLED AFTER APPLICATION.
 3. WHEN PVC TAPE IS USED AS A FINAL LAYER, PAINT FINISHED SPLICE WITH ELECTRICAL INSULATING COATING.

STANDARD DETAIL FOR PUBLIC WORKS CONSTRUCTION

POLE GROUNDING & SPLICE

SECTION: DOUGLAS COUNTY
 DATE: JULY 2017
 DWG: A21-B

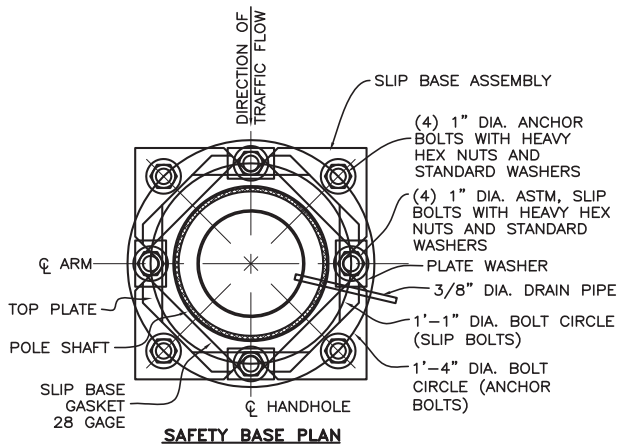

SAFETY BASE PLAN

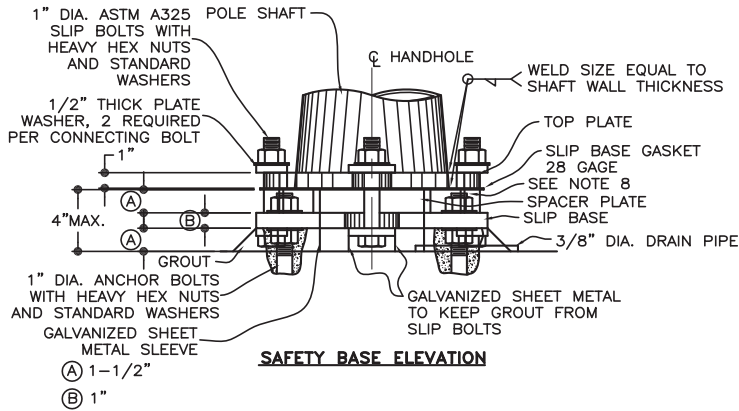

SAFETY BASE ELEVATION

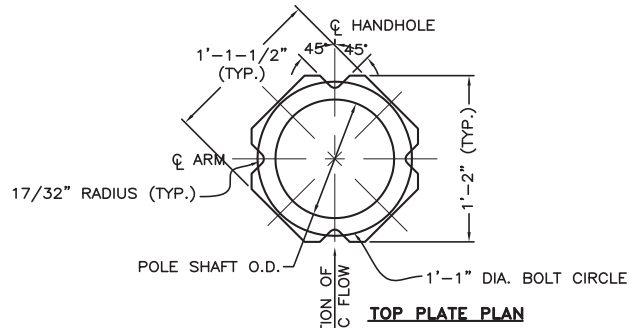

TOP PLATE PLAN



TOP PLATE ELEVATION

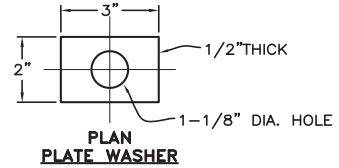
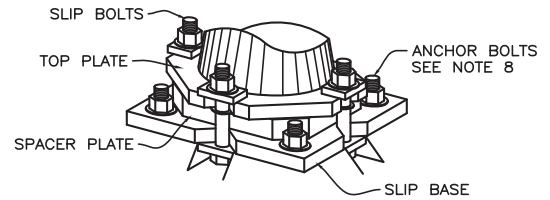

PLAN PLATE WASHER

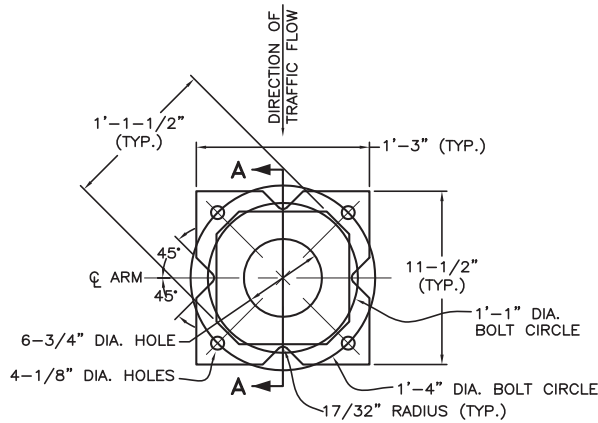

SLIP BASE & SPACER PLATE PLAN

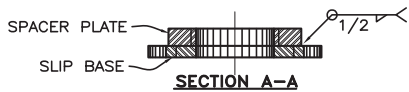

SECTION A-A

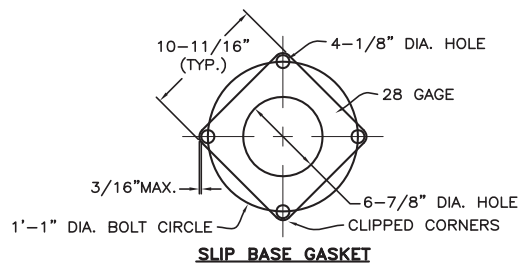

SLIP BASE GASKET

NOTES:

1. PLACE BOTTOM PLATE WITH SPACER PLATE ON LEVELING NUTS ON ANCHOR BOLTS AND FASTEN IN PLACE.
2. TOP PLATE SHALL BE FURNISHED BY LIGHT POLE FABRICATOR AS LIGHT POLE BASE PLATE WITH DIMENSIONS AS SHOWN IN PLAN VIEW.
3. ALL STEEL PLATE ASSEMBLIES SHALL BE HOT-DIP GALVANIZED AFTER FABRICATION.
4. ALL NUTS, BOLTS AND WASHERS SHALL BE ELECTRO-PLATED CADMIUM IN CONFORMANCE WITH ASTM B-766, TYPE NS.
5. ALL CONTACT AREAS OF PLATES SHALL BE FREE OF GALVANIZING BEADS OR RUNS.
6. SAFETY BASES SHALL BE UTILIZED ON ALL STEEL LIGHT POLES EXCEPT ON STRUCTURES OR IF PLACED BARRIER RAIL OR GUARDRAIL.
7. GROUTING SHALL BE DONE AFTER LIGHT POLE HAS BEEN LOCATED IN FINAL POSITION.
8. ANCHOR BOLT SHALL NOT EXTEND ABOVE SLIP BASE GASKET.
9. SLIP BOLT TORQUING REQUIREMENTS:
 - A. TORQUE ALL BOLTS TO 60 FOOT POUNDS.
 - B. LOOSEN BOLTS.
 - C. RETIGHTEN TO FINAL TORQUE USING THE FOLLOWING SEQUENCES:

1		
3	4	
	2	
 - D. CAULK AREAS AROUND SLIP BASE GASKET, MATERIAL SHALL CONFORM TO FED. SPEC. NO. TT-S-230 TYPE II OR EQUAL.
 - E. SPRAY CADMIUM BOLTS WITH GALVILITE COLD GALVANIZING COMPOUND OR EQUIVALENT.

NO.	REVISION	DATE	STANDARD DETAIL FOR PUBLIC WORKS CONSTRUCTION	SECTION: DOUGLAS COUNTY
			<h1>SAFETY BASE</h1>	DATE: JULY 2017
				DWG: A21-C

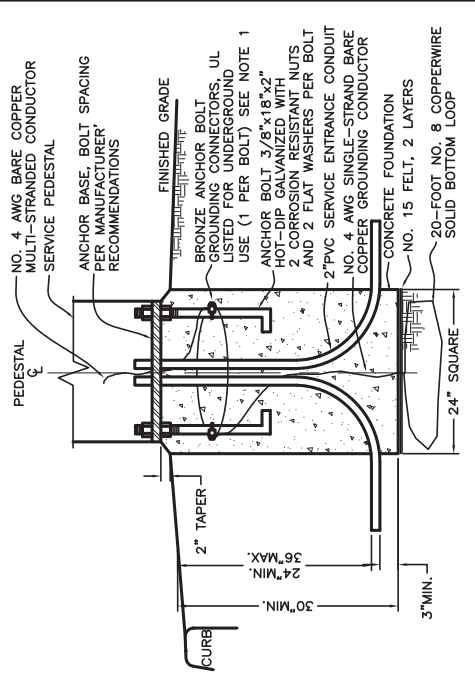
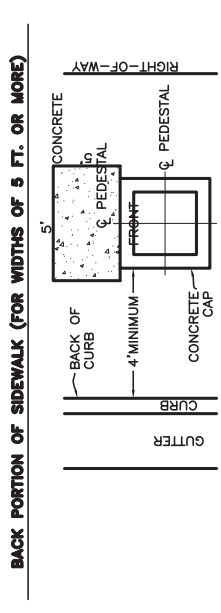
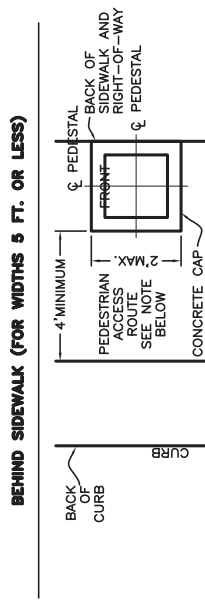
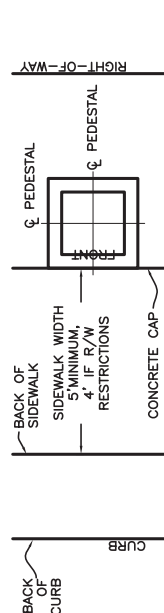
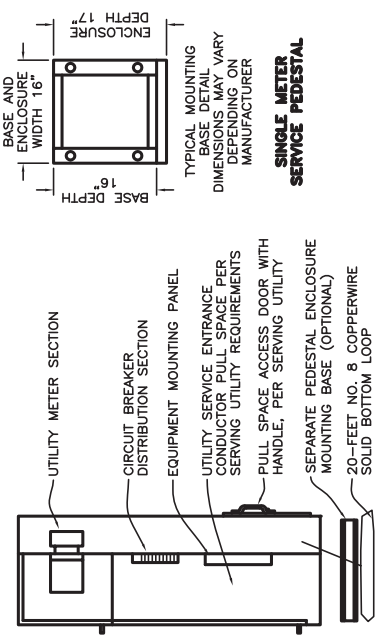
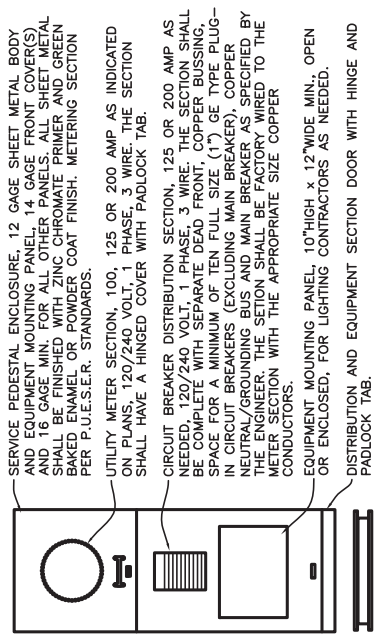

- NOTES:**
1. BARE COPPER GROUNDING CONNECTOR SHALL BE LOOPED AROUND ANCHOR BOLTS ONE TIME AND CONNECTED TO EACH ANCHOR BOLT BEFORE CONTINUING DOWN TO THE GROUNDING PLATE.
 2. CABINET COVERS SHALL BE PARALLEL WITH CURB.
 3. IN AREAS WHERE RIGHT-OF-WAY PERMITS, THE CONCRETE BASE SHALL BE PLACED AT THE BACK EDGE OF THE SIDEWALK.
 4. CABINET COVERS SHALL OPEN TOWARDS THE STREET WHEN CABINETS ARE LOCATED AT BACK OF WALK. CABINET COVERS SHALL OPEN PARALLEL TO THE SIDEWALK FACING THE DIRECTION OF TRAFFIC WHEN LOCATED WITHIN THE SIDEWALK.
 5. GROUND PLATE SHALL BE MADE OF NONFERROUS MATERIALS (TYPICALLY BRASS OR COPPER).

NO.	REVISION	DATE	STANDARD DETAIL FOR PUBLIC WORKS CONSTRUCTION

UNDERGROUND ELECTRICAL SERVICE

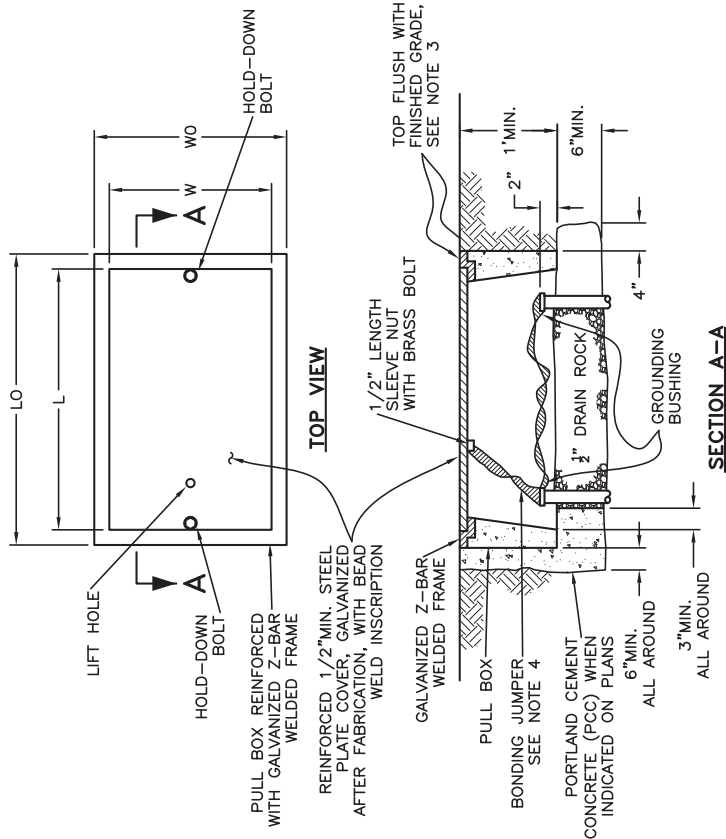

SECTION A-A

**No. 3-1/2 (T), No. 5 (T), No. 7 (T)
AND No. 9 (T) TRAFFIC RATED PULL BOX**

PULL BOX	CONCRETE BOX			STEEL COVER			EXTENSION	
	LO	WO	HEIGHT	L **	W **	EDGE TAPER	HEIGHT	HEIGHT
No. 3-1/2 (T)	±19"	±12"	±12"	±14-1/2"	±8-3/4"	NONE	12"	12"
No. 5 (T)	±25"	±15"	±12"	±20-1/2"	±10-1/2"	NONE	10"	10"
No. 7 (T)	±35"	±22"	±12"	±30"	±17"	NONE	8"	8"
No. 9 (T)	±52"	±35"	±14"	±47-3/4"	±30"	NONE	10"	10"

** TOP DIMENSION

NOTES:

1. TRAFFIC PULL BOX SHALL BE PROVIDED WITH STEEL COVER AND SPECIAL CONCRETE FOOTING. STEEL COVER SHALL HAVE EMBOSSED NON-SKID PATTERN.
2. STEEL REINFORCING SHALL BE AS REGULARLY USED IN THE STANDARD PRODUCTS OF THE RESPECTIVE MANUFACTURER.
3. TOP OF PULL BOXES SHALL BE FLUSH WITH SURROUNDING GRADE OR TOP OF ADJACENT CURB, EXCEPT THAT IN UNPAVED AREAS WHERE PULL BOX IS NOT IMMEDIATELY ADJACENT TO AND PROTECTED BY A CONCRETE FOUNDATION, POLE OR OTHER CONSTRUCTION, THE BOX SHALL BE PLACED WITH ITS TOP 1" ABOVE SURROUNDING GRADE, WHERE PRACTICABLE. PULL BOXES SHOWN IN THE VICINITY OF CURBS SHALL BE PLACED ADJACENT TO THE BACK OF CURB, AND PULL BOXES SHOWN ADJACENT TO STANDARDS SHALL BE PLACED ON SIDE OF FOUNDATION FACING AWAY FROM TRAFFIC, UNLESS OTHERWISE NOTED. WHEN PULL BOX IS INSTALLED IN SIDEWALK AREA, THE DEPTH OF THE PULL BOX SHALL BE ADJUSTED SO THAT THE TOP OF THE PULL BOX IS FLUSH WITH THE TOP OF SIDEWALK.
4. BONDING JUMPER FOR METAL COVERS SHALL BE 3'-4" LONG, MINIMUM.
5. THE NOMINAL DIMENSIONS OF THE OPENING IN WHICH THE COVER SETS SHALL BE THE SAME AS THE COVER DIMENSIONS EXCEPT THE LENGTH AND WIDTH DIMENSIONS SHALL BE 1/8" GREATER.
6. ALL COVERS AND BOXES SHALL BE INTERCHANGEABLE WITH NEVADA STANDARD MALE AND FEMALE GAUGES, WHEN INTERCHANGED WITH A STANDARD MALE OR FEMALE GAUGE, THE TOP SURFACES SHALL BE FLUSH WITHIN 1/8", TOP OUTSIDE EDGE OF ALL CONCRETE COVERS AND PULL BOXES SHALL HAVE A 1/4" MINIMUM RADIUS.
7. PULL BOX SHALL NOT BE INSTALLED WITHIN THE BOUNDARIES OF NEW OR EXISTING CURB RAMPS.
8. PULL BOXES FOR ELECTROLIERS AND SIGNAL STANDARDS SHALL BE LOCATED AT THE SAME STATION (±5') AS THE ADJACENT ELECTROLIER OR SIGNAL STANDARD. PULL BOXES SHALL BE PLACED ADJACENT TO BACK OF CURB OR EDGE OF SHOULDER EXCEPT WHERE THIS IS IMPRACTICAL. A BOX MAY BE PLACED IN ANOTHER SUITABLE PROTECTED AND ACCESSIBLE LOCATION.
9. IN AREAS WHERE THE POSSIBILITY OF MATERIAL ERODING FROM AROUND THE PULL BOX EXISTS, THE PULL BOX SHALL BE PLACED IN 3/4" DRAIN ROCK (2 FOOT DEPTH ON EACH SIDE AND 1 FOOT DEPTH), AS DIRECTED BY THE ENGINEER.

STANDARD DETAIL FOR PUBLIC WORKS CONSTRUCTION

**TRAFFIC RATED
ELECTRICAL PULL BOX**

SECTION:

DOUGLAS COUNTY

DATE: **JULY 2017**

DWG: **A21-E**

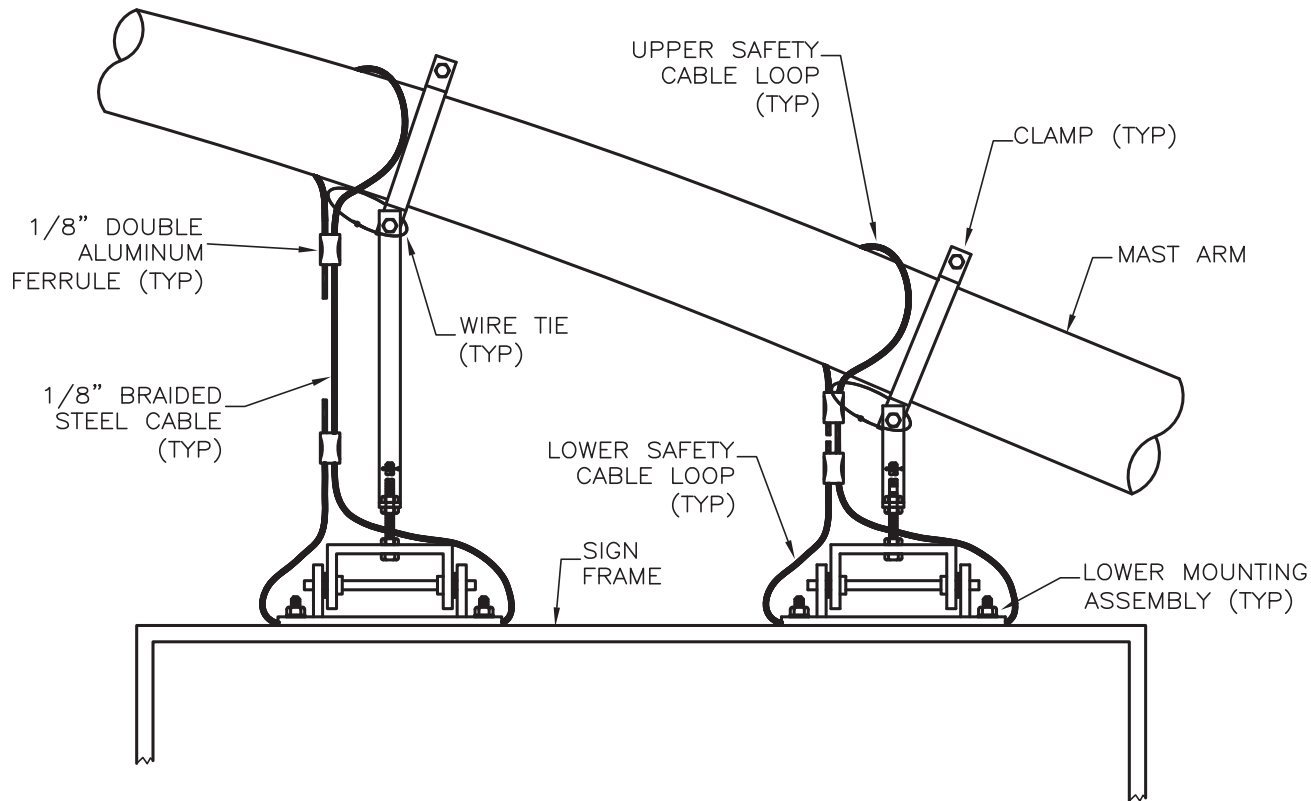

NOTES:

1. BOTH LOWER MOUNTING ASSEMBLIES SHALL HAVE A SAFETY CABLE INSTALLED.
2. MANUFACTURE EACH SAFETY CABLE FROM ONE CONTINUOUS LENGTH OF 1/8" BRAIDED ZINC COATED STEEL CABLE.
3. UPPER SAFETY CABLE LOOP AROUND MAST ARM SHALL BE ON THE UPPER SIDE OF CLAMP. SECURE UPPER SAFETY CABLE LOOP TO CLAMP WITH A WIRE TIE.
4. LOWER SAFETY CABLE LOOP SHALL BE INSTALLED BETWEEN LOWER MOUNTING ASSEMBLY AND SIGN FRAME.
5. INSTALL 1/8" DOUBLE ALUMINUM FERRULE ON UPPER AND LOWER LOOP ENDS. EACH FERRULE SHALL BE CRIMPED WITH AWG 1 DIE.
6. INSTALLED SAFETY CABLE SHALL NOT ALLOW SIGN TO FALL IN EXCESS OF ONE INCH.

NO.	REVISION	DATE	STANDARD DETAIL FOR PUBLIC WORKS CONSTRUCTION	SECTION: DOUGLAS COUNTY
			I.I.S.N.S. SAFETY CABLE	DATE: JULY 2017
				DWG: A22

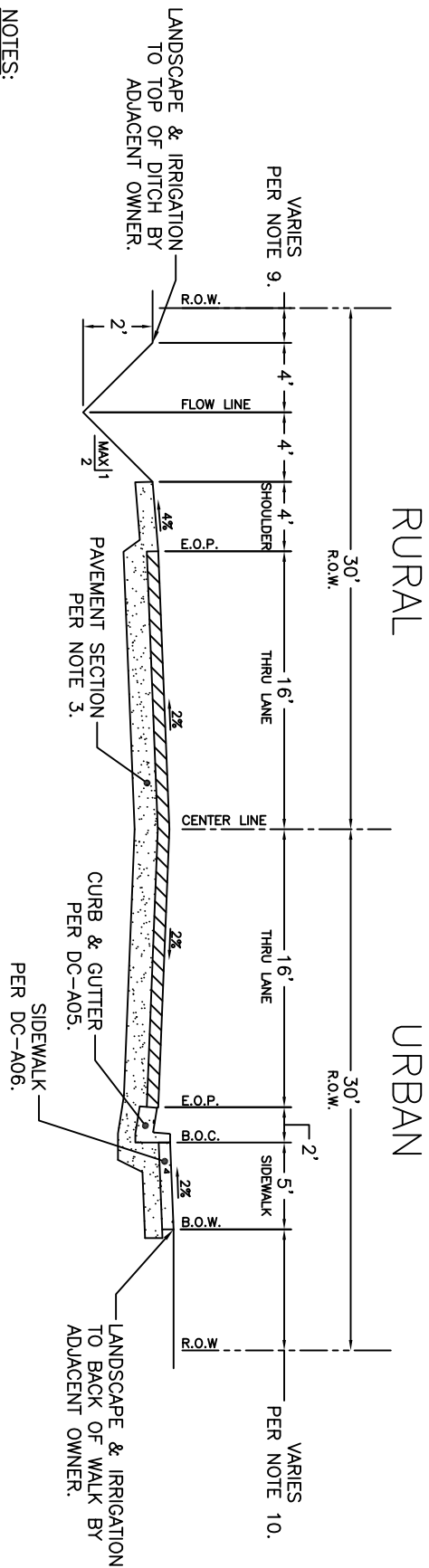

NOTES:

1. THIS ROAD SECTION IS APPLICABLE TO AREAS WITH AN INDUSTRIAL LAND USE.
- 1.1. PROJECTS LOCATED WITHIN AN URBAN SERVICE AREA BOUNDARY SHALL COMPLY WITH THE URBAN ROAD SECTION OF THIS DETAIL.
2. DIMENSIONS SHOWN ARE MINIMUMS.
- 2.1. IF THE NEW ROAD IS AN EXTENSION OF AN EXISTING ROAD, THE CROSS SECTION OF THE NEW ROAD SHALL MATCH THE EXISTING ROAD OR THIS DETAIL, WHICHEVER IS GREATER.
3. THE PAVEMENT SECTION SHALL BE DETERMINED BY ENGINEERING DESIGN, BUT IN NO CASE SHALL BE LESS THAN 4-INCHES OF ASPHALT CONCRETE ON 8-INCHES OF AGGREGATE BASE.
- 3.1. THE TOP LIFT OF ASPHALT SHALL CONSIST OF TYPE 3 PLANTMIX BITUMINOUS PAVEMENT WITH PG 64-28NV WITH A MINIMUM DEPTH OF 2-INCHES
- 3.2. LOWER LIFTS OF ASPHALT MAY CONSIST OF TYPE 2 PLANTMIX BITUMINOUS PAVEMENT WITH PG 64-28NV.
- 3.3. AGGREGATE BASE SHALL BE TYPE 2 CLASS B AND INSTALLED IN 8-INCH MAXIMUM LOOSE LIFTS.
4. THE GRAVEL SHOULDER FOR THE RURAL ROAD SECTION SHALL BE CONSTRUCTED TO A MINIMUM DEPTH OF 6-INCHES.
5. IF A TURN LANE IS REQUIRED OR DESIRED, THE TURN LANE SHALL BE A MINIMUM OF 12-FT WIDE AND HAVE THE SAME STRUCTURAL SECTION AS THE ROADWAY.
6. PAVED SHOULDERS, IF DESIRED, SHALL HAVE THE SAME STRUCTURAL SECTION AS THE ROADWAY.
7. WATERBORNE PAINTS SHALL BE EITHER TYPE II WATERBORNE OR EPOXY BASED PAINT.
- 7.1. WATERBORNE PAINT SHALL BE APPLIED IN TWO COATS, EACH COAT HAVING A MINIMUM WET THICKNESS OF 25 MM AND A MINIMUM DRY THICKNESS OF 15 MM MEASURED WITHOUT GLASS BEADS. EACH COAT SHALL INCLUDE GLASS BEADS APPLIED AT THE RATE OF 9 LBS/GALLON.
- 7.2. EPOXY BASED PAINT SHALL BE APPLIED IN A SINGLE COAT HAVING A MINIMUM DRY THICKNESS OF 20 MM MEASURED WITHOUT GLASS BEADS. GLASS BEADS SHALL BE APPLIED AT THE RATE OF 18 LBS/GALLON
8. LANDSCAPE AND IRRIGATION INSTALLED BY ADJACENT OWNER THAT FALLS WITHIN THE R.O.W. SHALL BE MAINTAINED BY THE ADJACENT OWNER, H.O.A. OR EQUIVALENT.
- 8.1. LANDSCAPING WITHIN THE ROADSIDE DITCH OF RURAL ROAD SECTION MAY BE ALLOWED WITH REVIEW AND APPROVAL BY COUNTY.
9. PROVIDE A MINIMUM DISTANCE OF 1-FT BETWEEN TOP OF DITCH AND R.O.W. WIDEN R.O.W. AS NEEDED TO ACCOMMODATE WIDER STREET SECTIONS.
10. PROVIDE A MINIMUM DISTANCE OF 1-FT BETWEEN BACK OF SIDEWALK AND R.O.W. WIDEN R.O.W. AS NEEDED TO ACCOMMODATE WIDER STREET SECTIONS.
11. PUBLIC WORKS CONSTRUCTION (THE ORANGE BOOK).

STANDARD DETAIL FOR PUBLIC WORKS CONSTRUCTION			SECTION: DOUGLAS COUNTY
<h1>LOCAL INDUSTRIAL TYPICAL ROAD SECTION</h1>			DATE: DEC. 2020
			DWG: A23
NO.	REVISION	DATE	



Appendix B

Water System Details

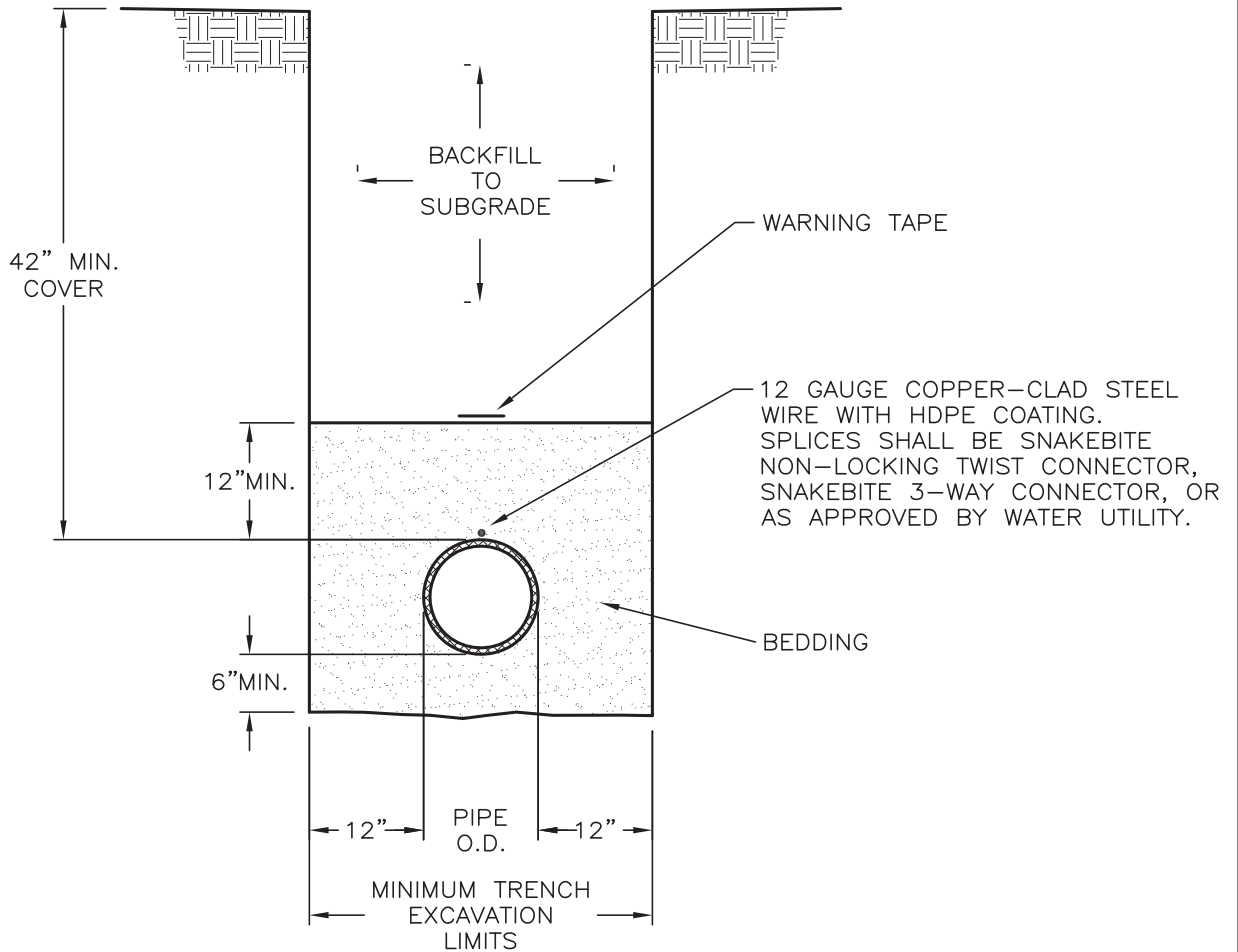

NOTES:

1. BACKFILL SHALL CONFORM TO THE REQUIREMENTS OF CLASS A (IMPORTED) OR CLASS E (NATIVE) BACKFILL AS SPECIFIED IN SUBSECTION 200.03 OF THE STANDARD SPECIFICATIONS FOR PUBLIC WORKS CONSTRUCTION. MATERIAL SHALL BE PLACED IN LIFT THICKNESS SPECIFIED IN SUBSECTION 305 OF THE STANDARD SPECIFICATIONS FOR PUBLIC WORKS CONSTRUCTION AND DENSIFIED TO 90% RELATIVE COMPACTION.
2. BEDDING SHALL CONFORM TO THE REQUIREMENTS OF CLASS A BACKFILL AS SPECIFIED IN SUBSECTION 200.03.02 OF THE STANDARD SPECIFICATIONS FOR PUBLIC WORKS CONSTRUCTION. MATERIAL SHALL BE DENSIFIED TO 90% RELATIVE COMPACTION.
3. CLASS C BACKFILL OR OTHER GRADATION AS APPROVED BY WATER UTILITY, WITH FILTER FABRIC MAY BE USED TO SUPPORT BEDDING IN HIGH GROUNDWATER OR UNSTABLE SOIL CONDITIONS WITH THE APPROVAL OF THE WATER UTILITY. FILTER FABRIC SHALL BE WRAPPED AROUND BEDDING SECTION WITH 2 FOOT OVERLAP ON TOP.
4. FOR STRUCTURAL (PAVEMENT) SECTION, SEE "STREET CUT REPAIR" DETAIL A14.
5. SHORING OR SLOPED CUT SLOPES MAY BE NECESSARY. ALL EXCAVATIONS SHALL CONFORM TO THE MOST RECENT OSHA REQUIREMENTS.
6. PLACE WARNING TAPE 1 FOOT ABOVE WATER AND RECLAIMED WATER PIPE.
7. WATER STOPS SHALL BE USED IN HIGH GROUND WATER CONDITIONS PER "WATER STOP" DETAIL B02. FOR WET TRENCH BEDDING SEE DETAIL C01.
8. FOR USE OUTSIDE PAVED ROAD SECTION.

NO.	REVISION	DATE	STANDARD DETAIL FOR PUBLIC WORKS CONSTRUCTION	SECTION: DOUGLAS COUNTY
			TRENCH EXCAVATION & BACKFILL	DATE: JULY 2017
				DWG: B01

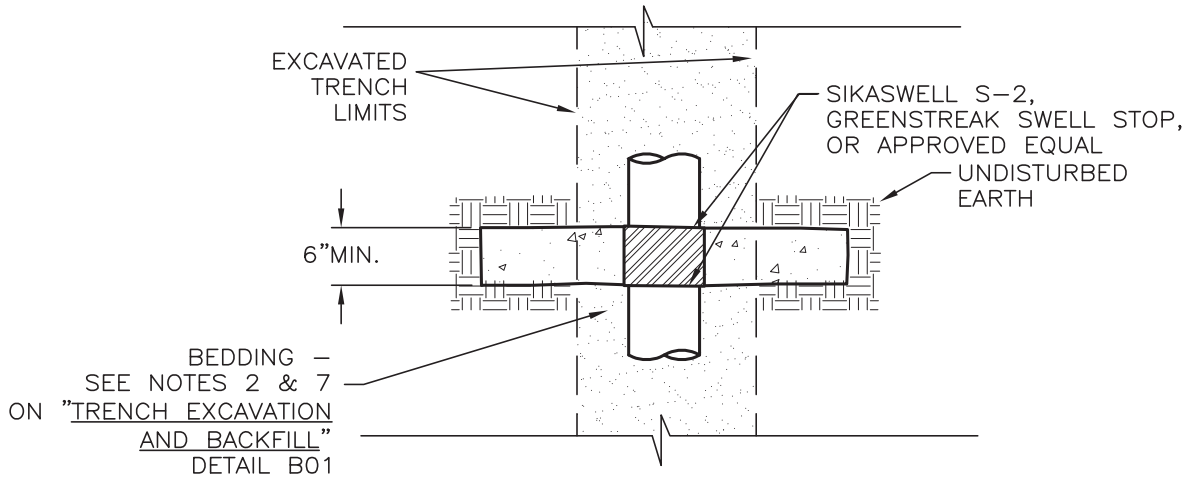

PLAN

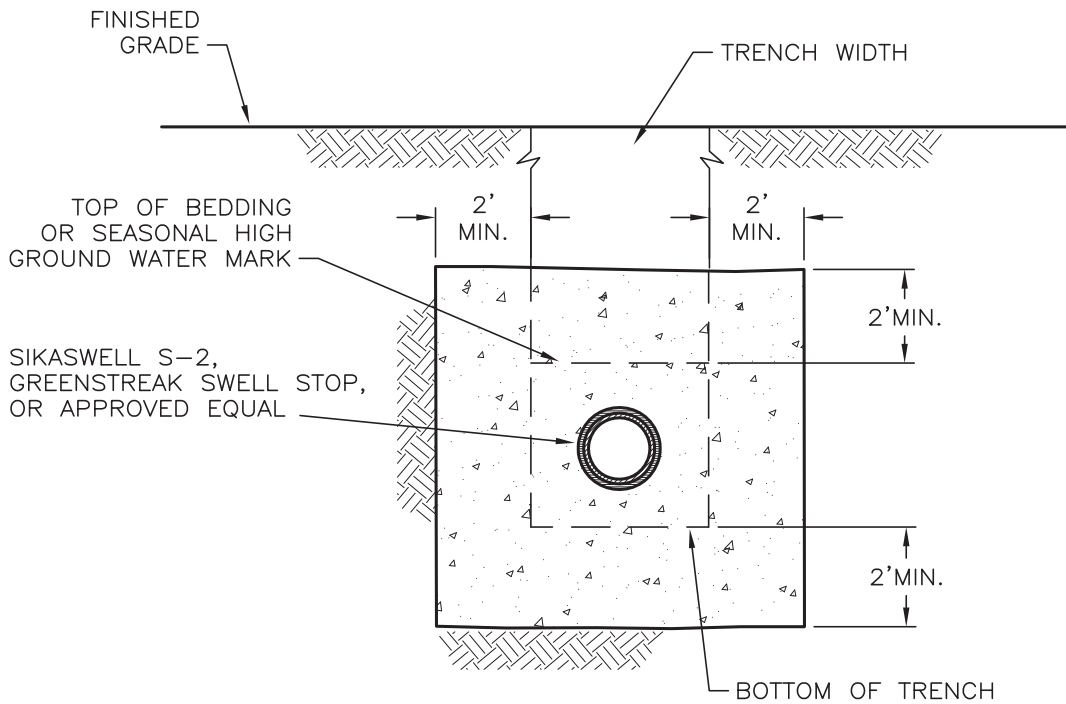

SECTION

NOTES:

1. WATER STOPS SHALL BE CONSTRUCTED AT 200-FOOT MAXIMUM SPACING IN GROUND WATER CONDITIONS AND WHERE WET TRENCH BEDDING IS USED, AS DIRECTED BY WATER UTILITY.
2. WRAP PIPE WITH SIKASWELL S-2, OR GREENSTREAK SWELL STOP, OR EQUIVALENT WHERE PIPE IS EXPOSED TO CONCRETE PRIOR TO POURING.
3. USE LIGHT CONCRETE, TYPE A SLURRY BACKFILL PER ORANGE BOOK 337.08.01-1. IF CEMENT BOARD IS USED FOR CONCRETE FORMS, IT MAY BE LEFT IN PLACE.

NO.	REVISION	DATE	STANDARD DETAIL FOR PUBLIC WORKS CONSTRUCTION	SECTION: DOUGLAS COUNTY
			WATER STOP	DATE: JULY 2017
				DWG: B02

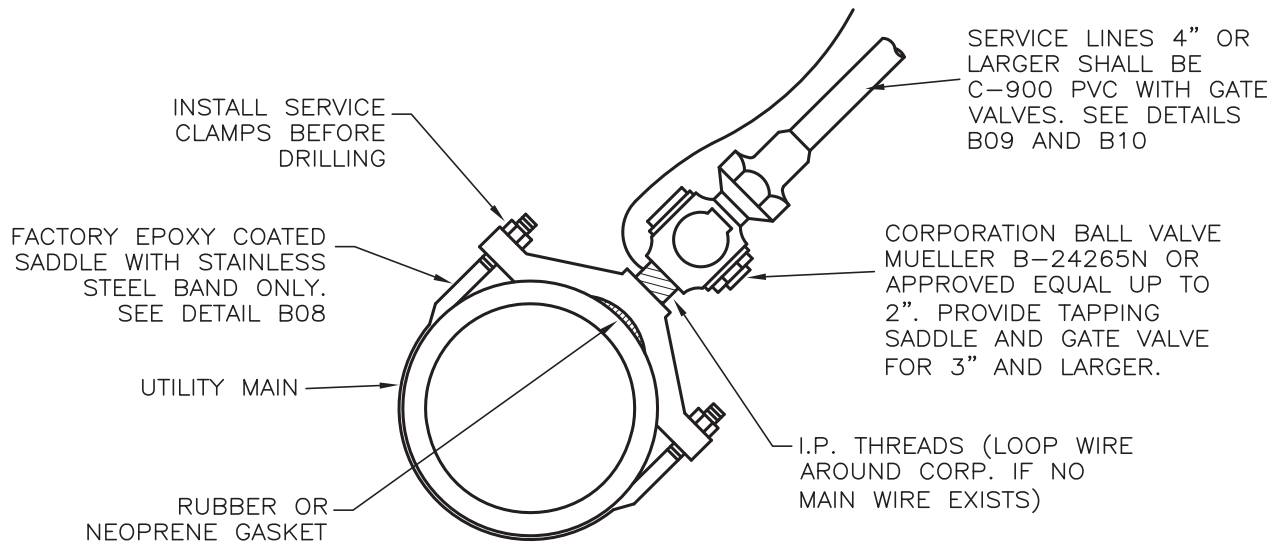
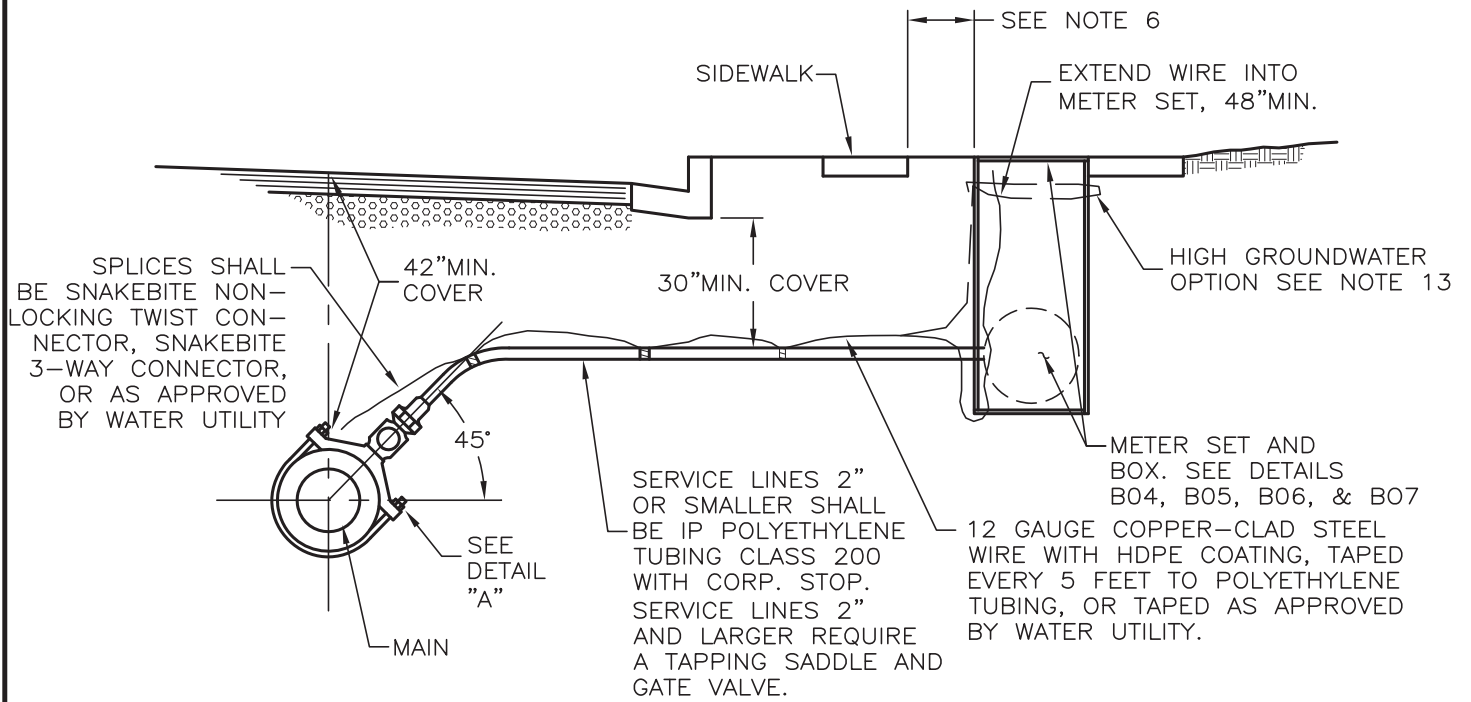

DETAIL "A"

SEE NOTES ON PAGE 2

NO.	REVISION	DATE	STANDARD DETAIL FOR PUBLIC WORKS CONSTRUCTION	SECTION: DOUGLAS COUNTY
			WATER SERVICE	DATE: JULY 2017
				DWG: B03

NOTES:

1. ALL APPURTENANCES SHALL BE AS SPECIFIED, UNLESS APPROVED AS EQUAL BY WATER UTILITY.
2. ALL SERVICE LINE COUPLING FITTINGS SHALL BE MUELLER IPS 110 COMP x MIP, FORD FB1100-NL OR APPROVED EQUAL. ALL POLYETHYLENE SERVICE LINES SHALL MEET REQUIREMENTS OF AWWA STANDARD C901. A STOP AND WASTE VALVE MUST NOT BE USED ON A SERVICE LINE WITHIN THE RIGHT-OF-WAY, BETWEEN MAIN AND METER.
3. ALL SERVICE VALVES SHALL BE SAME SIZE OR LARGER THAN SERVICE LINES (ON 3-INCH SERVICE, USE 4-INCH GATE VALVE AND PIPE).
4. SERVICE CLAMPS SHALL BE FACTORY COATED EPOXY WITH STAINLESS STEEL BAND.
5. THERE SHALL BE A MINIMUM CLEAR DISTANCE OF 18-INCHES BETWEEN TAPS AND FITTINGS, INCLUDING MAINLINE JOINTS AND BELLS.
6. ALL METER SETS TO BE PLACED 12-INCHES FROM BACK FACE OF SIDEWALK. IN AREAS WHERE NO SIDEWALK IS PRESENT, THE METER SHALL BE LOCATED AT A POINT AS CLOSE AS PRACTICABLE TO THE PROPERTY LINE, ALLEYS, OR EASEMENTS. ALL METER SETS SHALL BE PLACED WITHIN THE PUBLIC RIGHT-OF-WAY OR PUBLIC UTILITY EASEMENT.
7. TAPPING SLEEVES 3-INCHES OR LARGER SHALL BE STAINLESS STEEL, HAVE A FULL CIRCUMFERENTIAL SEAL AND HAVE EITHER A STAINLESS STEEL OR DUCTILE IRON FLANGE. SEE "TAPPING SLEEVE" DETAIL B09.
8. UPON ABANDONING OF SERVICE TAP, WATER UTILITY SHALL BE NOTIFIED SO THAT THE EXISTING METER CAN BE REMOVED.
9. ENTITY REQUESTING ABANDONMENT SHALL REMOVE EXISTING METER BOX AFTER COORDINATION WITH WATER UTILITY AND EXPOSE CORP STOP FOR SHUTOFF. ALL PLUMBING SHALL BE DISCONNECTED FROM CORP STOP. WATER UTILITY SHALL BE NOTIFIED FOR INSPECTION OF CORP ASSEMBLY PRIOR TO BACKFILLING.
10. ALL APPURTENANCES SHALL MEET THE CURRENT ADOPTED EDITION OF THE UNIFORM PLUMBING CODE (UPC).
11. EACH SERVICE LINE SHALL HAVE A CURB STOP OR METER STOP IN ADDITION TO THE CORPORATION STOP.
12. A "W" SHALL BE STAMPED ON THE CURB FACE AT THE LOCATION OF THE LATERAL CROSSING THE CURB LINE.
13. IN HIGH GROUNDWATER LOCATIONS TRACER WIRE MAY BE INSTALLED OUTSIDE OF THE WATER METER BOX.

NO.	REVISION	DATE	STANDARD DETAIL FOR PUBLIC WORKS CONSTRUCTION	SECTION: DOUGLAS COUNTY
			WATER SERVICE	DATE: JULY 2017
				DWG: B03

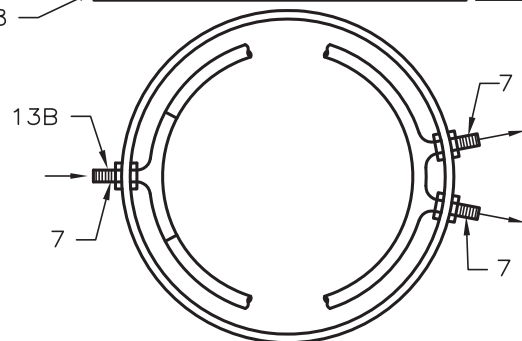
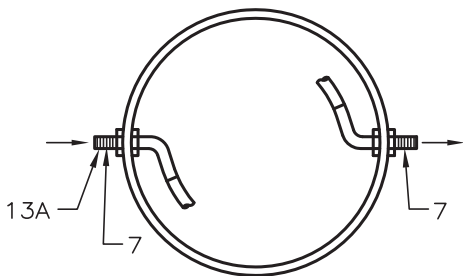
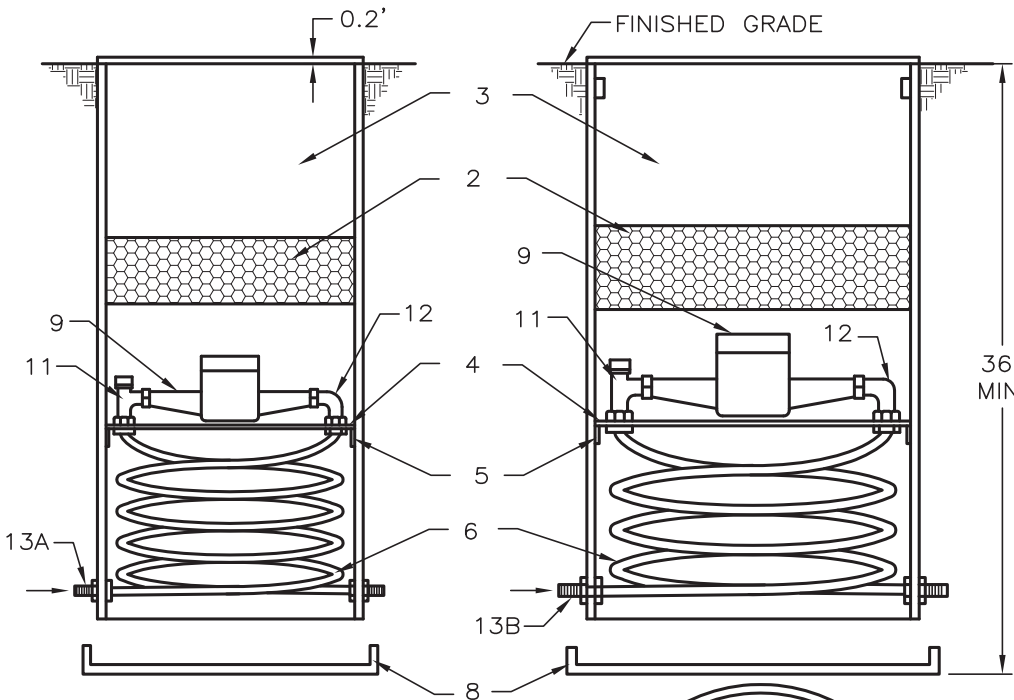
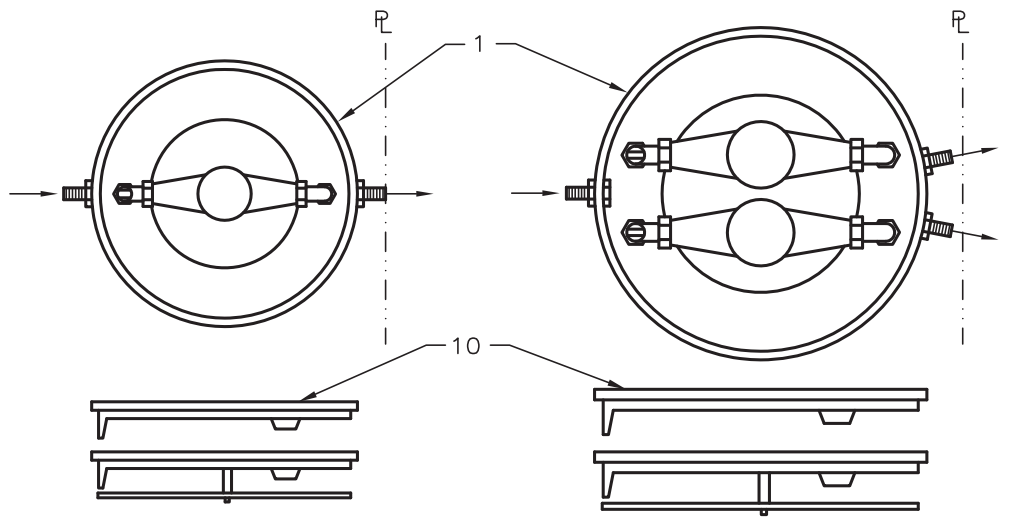

SEE NOTES
ON PAGE 2

**15" DIAMETER THERMAL
COIL METER BOX FOR
SINGLE PIT SETTER**

**18" DIAMETER THERMAL COIL
METER BOX FOR 3/4" DOUBLE,
1" SINGLE PIT SETTER**

NO.	REVISION	DATE	STANDARD DETAIL FOR PUBLIC WORKS CONSTRUCTION	SECTION: DOUGLAS COUNTY
			3/4" SINGLE & DOUBLE SERVICE PIT, 1" SINGLE SERVICE PIT	DATE: JULY 2017
				DWG: B04

NOTES:

1. SERVICE LINE SIZE AS REQUIRED BY WATER UTILITY (3/4" – 1") WITH COUPLING ADAPTOR.
2. PIT SETTER EXTENSION SHALL ONLY BE USED UPON APPROVAL BY THE WATER UTILITY.
3. ALTERNATE DESIGNS ARE REQUIRED WHERE METER BOX IS WITHIN DRIVEWAY OR OTHER TRAFFIC AREAS.
4. TOP OF METER PIT SHALL BE SET 0.2 FEET (2.4 INCHES) ABOVE FINISHED GRADE.

PARTS KEY:

1. PVC BOX, MINIMUM WALL THICKNESS 0.300".
2. MUELLER 4" THICK INSULATION PAD.
3. AIR SPACE.
4. PLATFORM.
5. PLATFORM SUPPORT.
6. POLYBUTYLENE TUBING CLASS 250.
7. I.P. THREADS.
8. CONTRACTOR SHALL CONSTRUCT DRAIN HOLES IN BOTTOM OF METER PIT WITH DIGGING BAR OR AS REQUIRED BY WATER UTILITY. PLACE METER PIT BOTTOM ON REDWOOD 2" x 6" AND INSTALL 6-INCH SECTION OF DRAIN ROCK UNDER PIT FOR REDWOOD TO REST ON.
9. WATER METER AND RADIO READ HARDWARE AS APPROVED BY WATER UTILITY. (KGID DOES NOT SUPPLY WATER METER).
10. CAST IRON LOCKING LID WITH SINGLE TR/PL HOLE(S).
11. MUELLER VALVE OR APPROVED EQUAL (NO. H 14265).
12. MUELLER ANGLE CHECK VALVE OR EQUAL.
- 13A. INLET LINE TO BE 3/4" MINIMUM.
- 13B. 1" MINIMUM. INLET LINE TO BE 1" MINIMUM.

NO.	REVISION	DATE	STANDARD DETAIL FOR PUBLIC WORKS CONSTRUCTION	SECTION: DOUGLAS COUNTY
			3/4" SINGLE & DOUBLE SERVICE PIT, 1" SINGLE SERVICE PIT	DATE: JULY 2017
				DWG: B04

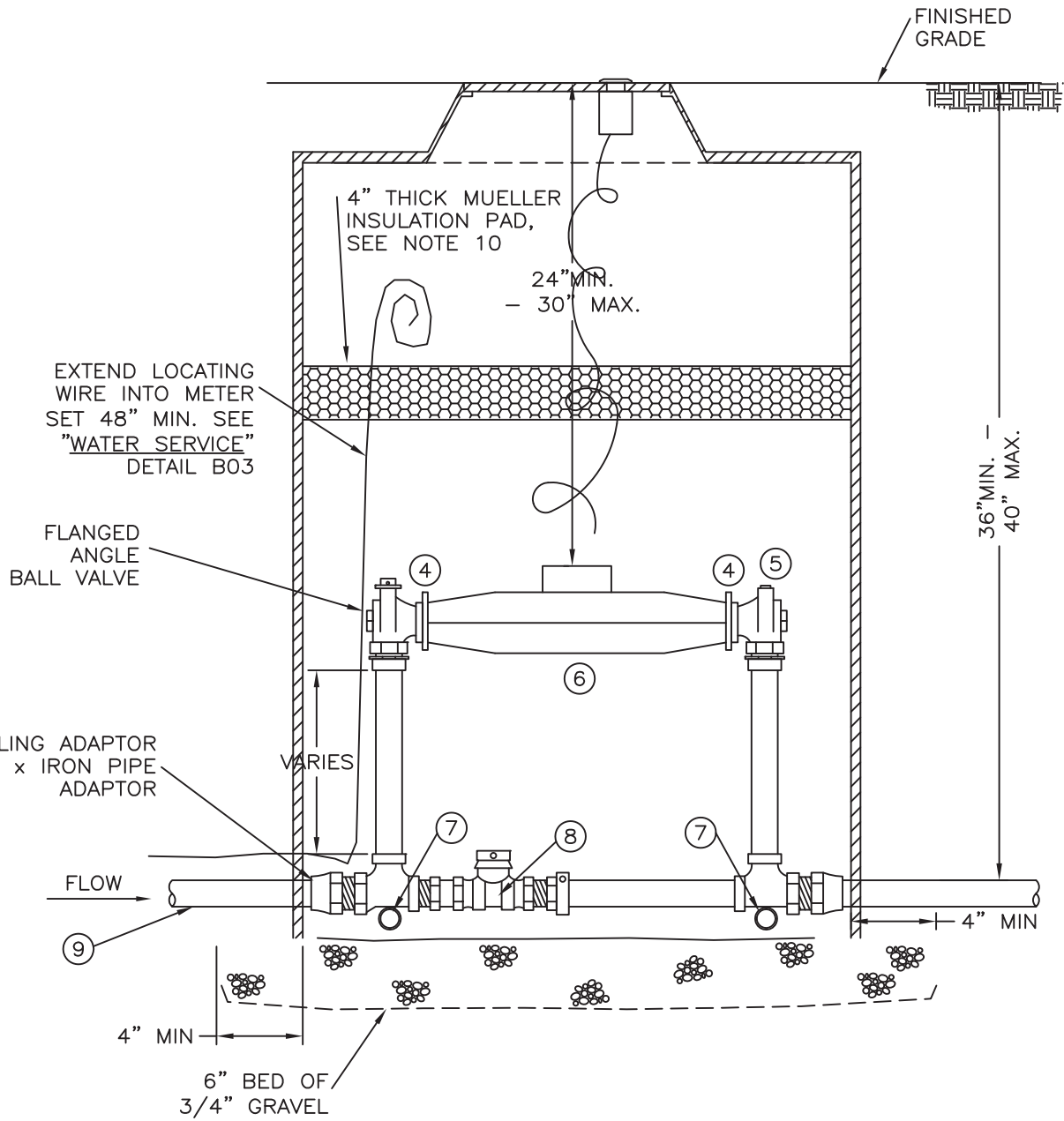

SEE NOTES ON PAGE 2

NO.	REVISION	DATE	STANDARD DETAIL FOR PUBLIC WORKS CONSTRUCTION	SECTION: DOUGLAS COUNTY
			<p>1 1/2" - 2" METER SET</p>	DATE: JULY 2017
				DWG: B05

NOTES AND PARTS KEY:

1. USE A TRAFFIC RATED LID AND BOX WITH READING LID IN ALL TRAFFIC AREAS.
2. METER SHALL BE INSTALLED SO AS TO ACHIEVE A WATER TIGHT SEAL.
3. CUT TWO PIECES OF 1 INCH PIPE 18 INCHES LONG AND INSTALL THROUGH THE BRACE EYE SUPPORTS.
4. SINGLE METER GASKET.
5. FLANGED ANGLE BALL CHECK VALVE.
6. WATER METER AND RADIO READ HARDWARE AS APPROVED BY WATER UTILITY. (KGID DOES NOT SUPPLY WATER METER).
7. BRACE EYE SUPPORTS.
8. BY-PASS BALL VALVE WITH LOCKABLE CAP.
9. POLYETHYLENE TUBING (SIZE AS REQUIRED BY WATER UTILITY). MINIMUM TEST 200 PSI.
10. 4" THICK MUELLER INSULATION PAD OR 4' X 4' BLANKET INSULATION TO BE INSTALLED ABOVE METER AND BELOW TRANSMITTER.

NO.	REVISION	DATE	STANDARD DETAIL FOR PUBLIC WORKS CONSTRUCTION	SECTION: DOUGLAS COUNTY
			<p>1 1/2" - 2" METER SET</p>	DATE: JULY 2017
				DWG: B05

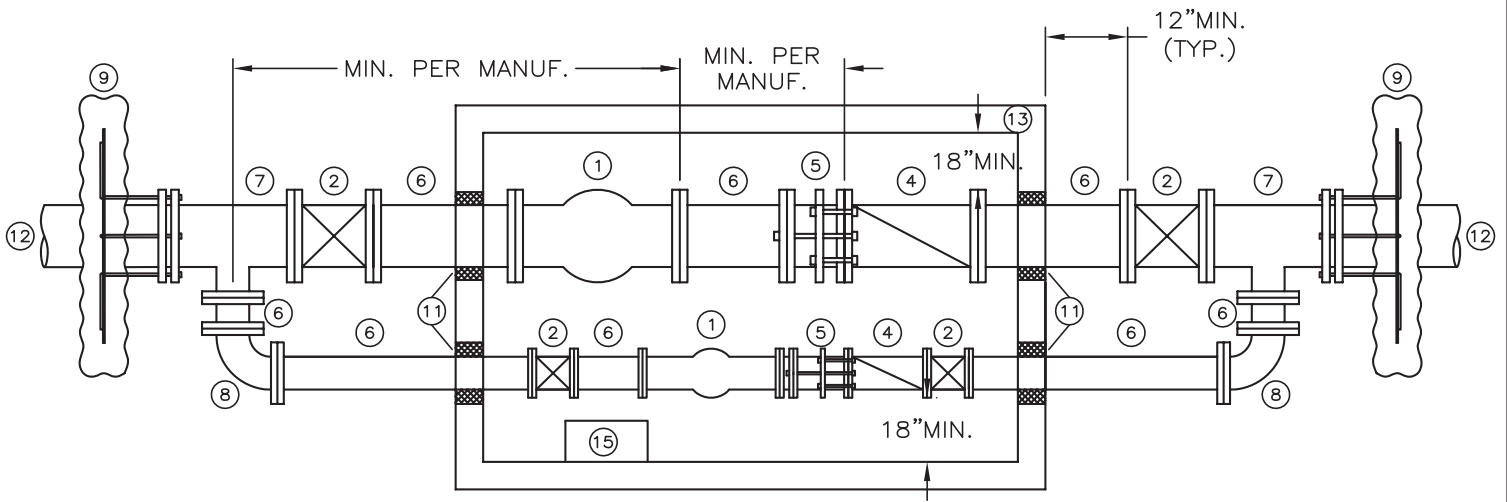
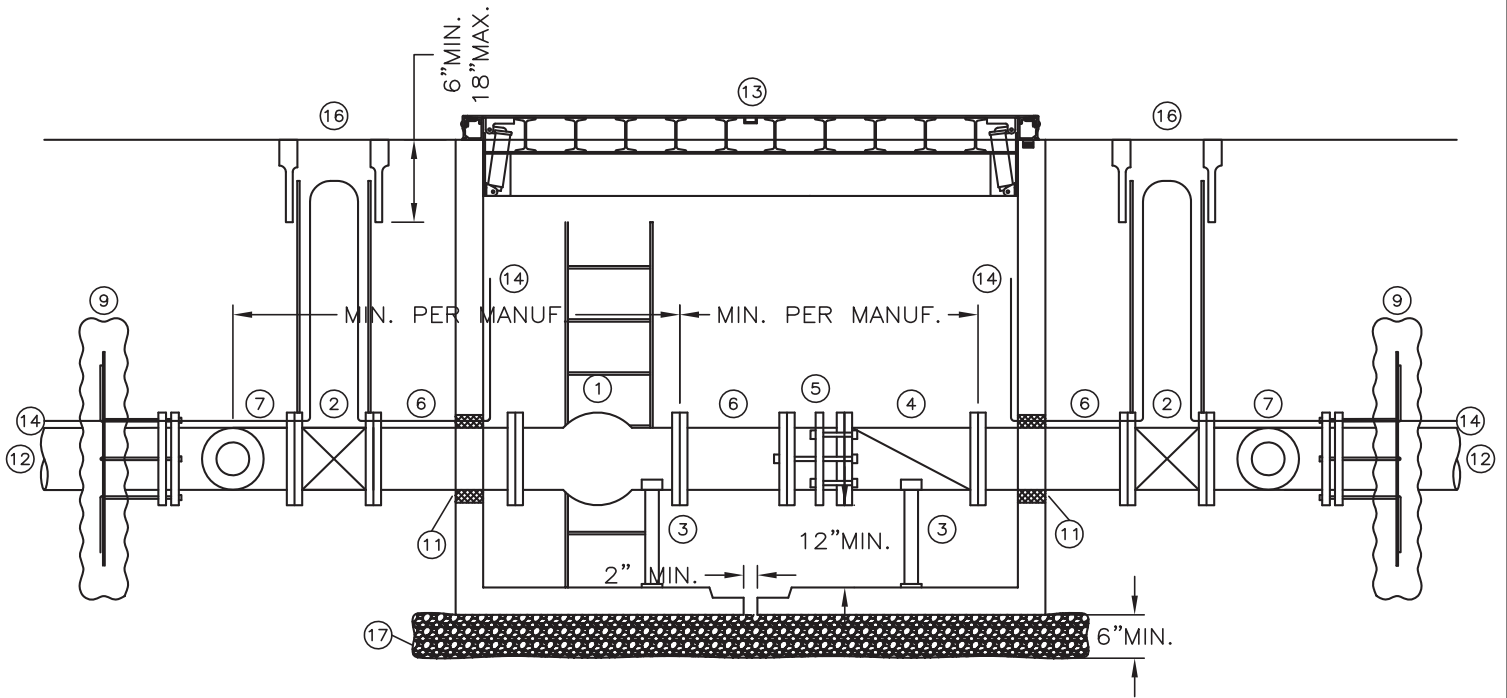

NO.			REVISION			DATE			STANDARD DETAIL FOR PUBLIC WORKS CONSTRUCTION			SECTION: DOUGLAS COUNTY		
									<h1>3" TO 8" METER SET</h1>			DATE: JULY 2017		
												DWG: B06		

PARTS KEY:

1. WATER METER [MAIN METER SIZED FOR PEAK AND MINIMUM DEMAND, BYPASS METER (IF REQUIRED BY UTILITY) SIZED FOR MINIMUM DEMAND], RADIO READ HARDWARE AS APPROVED BY WATER UTILITY, AND STRAINER (IF REQUIRED BY UTILITY). CONTRACTOR TO VERIFY WITH WATER UTILITY AS TO WHO SUPPLIES METER.
2. MUELLER GATE VALVE, NRS, AWWA C509. C/W OPERATING NUT OR APPROVED EQUAL.
3. GRINNELL OR BLA PIPE SUPPORTS.
4. MUELLER SWING CHECK VALVE OR APPROVED EQUAL.
5. ROMAC DJ400 DISMANTLING JOINT OR APPROVED EQUAL.
6. DUCTILE IRON PIPE, AWWA C115/C151. 250 PSI MINIMUM PRESSURE RATING.
7. TEE, AWWA C110/C153. 250 PSI MINIMUM PRESSURE RATING.
8. 90° BEND, AWWA C110/C153. 250 PSI MINIMUM PRESSURE RATING.
9. "HAMMERHEAD" THRUST BLOCK WITH JOINT RESTRAINT SIZED FOR APPLICATION ON UNDISTURBED SOIL. EXPOSED REINFORCEMENT TO BE STAINLESS STEEL OR IRON. MINIMUM 3-INCH CLEARANCE ON ALL CONCRETE REINFORCEMENT.
10. PRECAST CONCRETE VAULT, H2O LOAD RATED, WATERPROOF VAULT EXTERIOR WITH 2 COATS OF THOROSEAL/ACRYL 60 OR APPROVED EQUAL. VAULT TO BE SIZED SUCH THAT A MINIMUM OF 1'-6" HORIZONTAL CLEARANCE IS PROVIDED BETWEEN VAULT WALLS AND PIPING/APPURTEANCES AND BETWEEN PIPE/APPURTEANCES. A MINIMUM OF 1'-0" VERTICAL CLEARANCE IS TO BE PROVIDED BETWEEN PIPING/APPURTEANCES AND THE VAULT FLOOR. MINIMUM INTERIOR DIMENSIONS 6'-6"X4'-0"X5'-6", VAULT TO BE CAST WITH A SUMP. DRY INSTALLATIONS OUTSIDE OF ANY IMPACT FROM GROUNDWATER ARE TO HAVE A DRAIN HOLE CORED IN THE SUMP.
11. LINK-SEAL OR APPROVED EQUAL IN WET/GROUNDWATER INSTALLATIONS. KOR-N-SEAL BOOT IN DRY INSTALLATIONS
12. AWWA C900 PVC PIPE FOR 4-INCH THROUGH 8-INCH, AWWA C901 IPS HDPE PIPE FOR 3 INCH.
13. 48-INCH x 78-INCH ALUMINUM ACCESS COVER WITH STAINLESS STEEL HARDWARE, DRAIN CHANNEL, CONTINUOUS BUMPER SEAL, AND COMPRESSION SPRINGS (BILCO JDAL-H2O TRAFFIC RATED) OR APPROVED EQUAL FOR INCIDENTAL TRAFFIC AREAS. ACCESS COVERS CONSTRUCTED OUT OF STEEL OR THAT UTILIZE TORSION SPRINGS WILL NOT BE ALLOWED. 48-INCH X 78-INCH DIAMOND PLATE TOP SLAB WITH 36-INCH RING AND COVER FOR FULL H2O TRAFFIC LOAD.
14. 12 GAUGE COPPER-CLAD STEEL WIRE WITH HDPE COATING LOCATION WIRE, EXTEND 48 INCHES INTO METER BOX.
15. STEEL LADDER WITH LADDER-UP SAFETY POST, BILCO LU-1 OR APPROVED EQUAL.
16. TRAFFIC RATED VALVE BOX.
17. 3/4-INCH WASHED DRAIN ROCK.

NOTES:

1. BYPASS LINES REQUIRED BASED ON INSTALLATION. CONSULT WITH UTILITY TO DETERMINE IF A BYPASS LINE IS REQUIRED.
2. METER VAULT IS TO BE CONSTRUCTED SUCH THAT NO EXTERIOR WATER (INFILTRATION OR INFLOW) IS ALLOWED TO ENTER THE VAULT.
3. METER MANUFACTURER'S RECOMMENDED UPSTREAM AND DOWNSTREAM CLEAR OPEN PIPE REQUIREMENTS ARE TO INCORPORATED INTO THE VAULT DESIGN.
4. ALL PIPE, VALVES, METERS, AND ANY OTHER ITEM THAT WILL BE IN DIRECT CONTACT WITH POTABLE WATER MUST BE NSF 61 APPROVED.

NO.	REVISION	DATE	STANDARD DETAIL FOR PUBLIC WORKS CONSTRUCTION	SECTION: DOUGLAS COUNTY
			3" TO 8" METER SET	DATE: JULY 2017
				DWG: B06

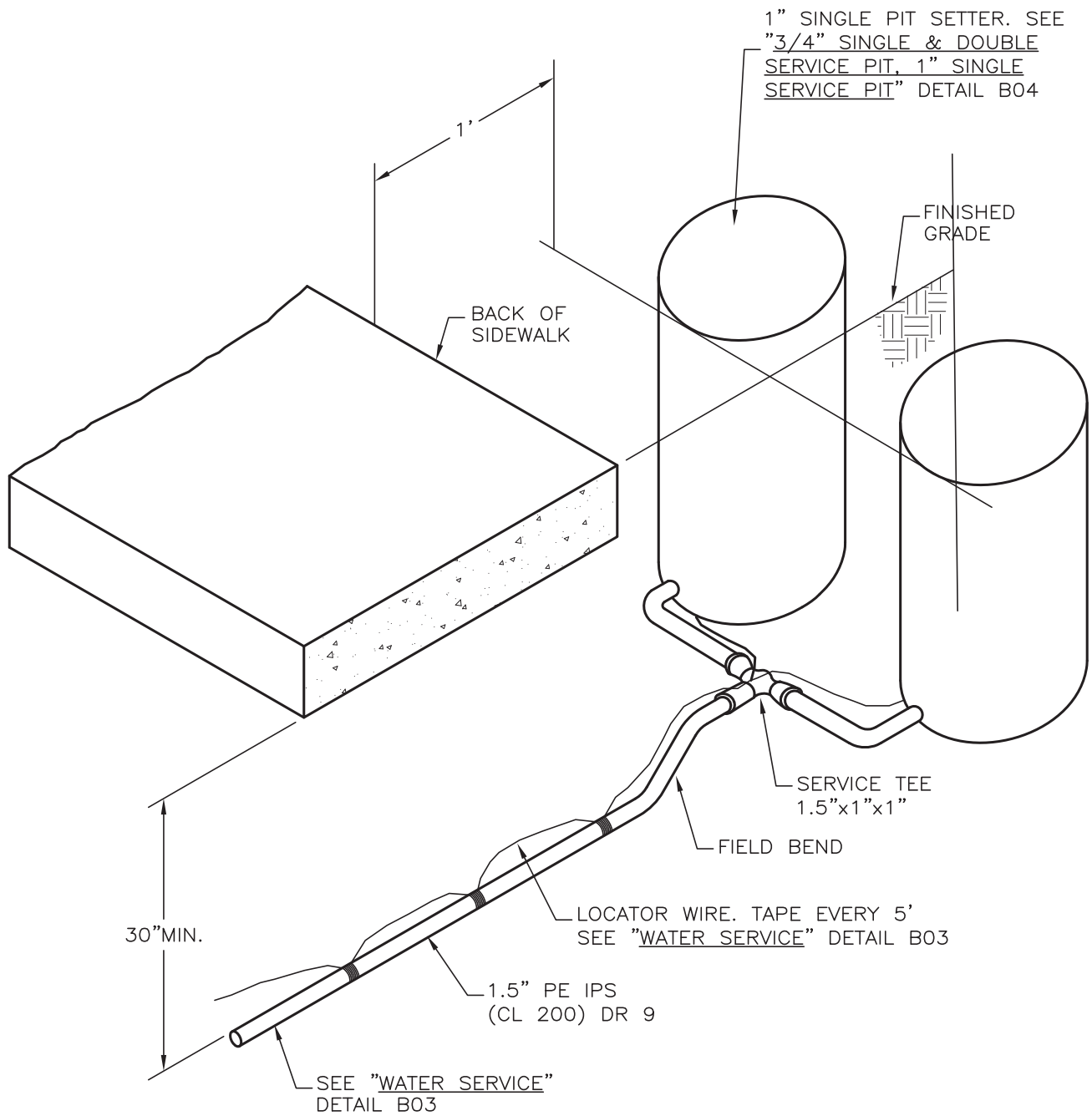

NOTES:

1. ALL SERVICE LINE COUPLING FITTINGS SHALL BE MUELLER IPS 110 COUP. X MIP OR APPROVED EQUAL.
2. THE METER SHALL BE LOCATED AT A POINT AS CLOSE AS PRACTICABLE TO THE PROPERTY LINE, ALLEYS, OR EASEMENTS.
3. NO DUAL 1-INCH SERVICE IN GARDNERVILLE WATER COMPANY SERVICE AREA.

NO.			REVISION			DATE			STANDARD DETAIL FOR PUBLIC WORKS CONSTRUCTION			SECTION: DOUGLAS COUNTY		
									<h1>1" DUAL METER SET</h1>			DATE: JULY 2017		
												DWG: B07		

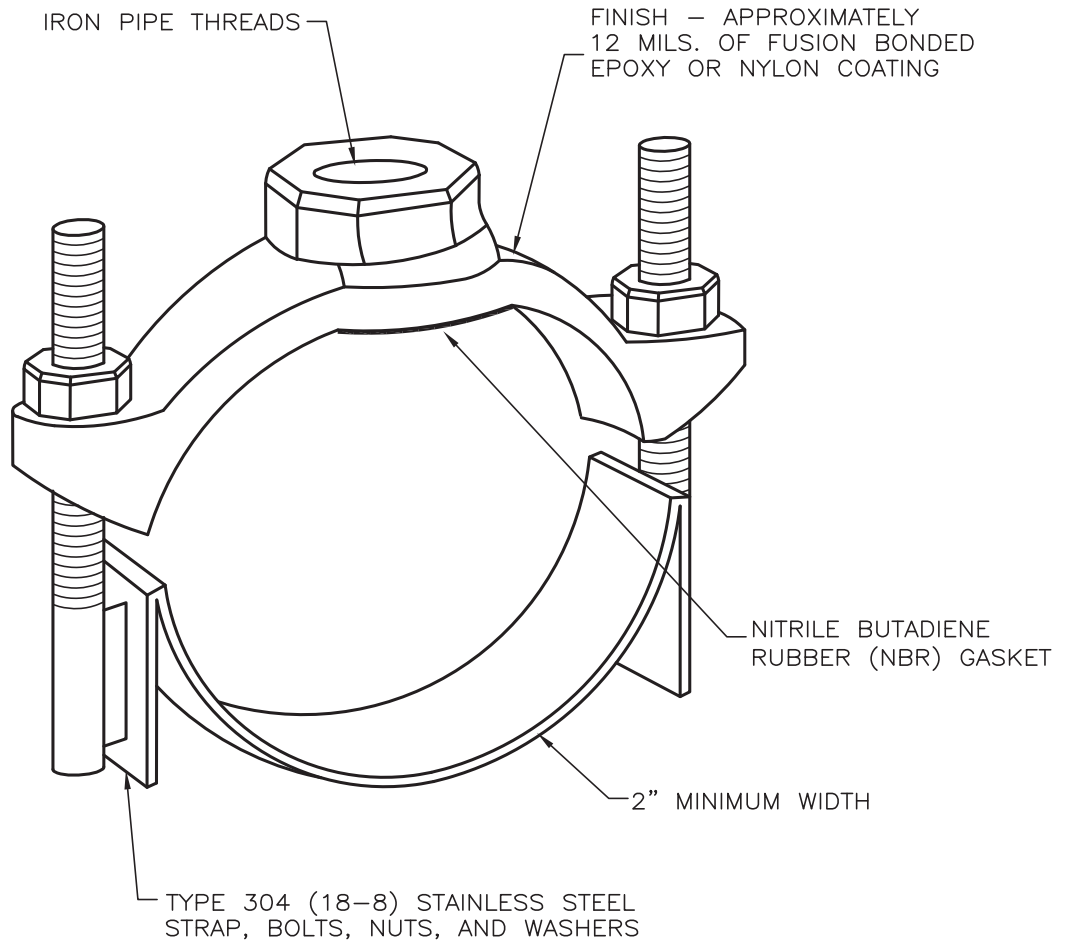

NOTES:

1. SEE ALSO "WATER SERVICE" DETAIL B03.
2. SINGLE OR DOUBLE STRAP MAY BE UTILIZED FOR 3/4-INCH AND 1-INCH SERVICES, AS DIRECTED BY WATER UTILITY.
3. DOUBLE STRAPS SHALL BE UTILIZED FOR 1 1/2-INCH AND 2-INCH SERVICES.
4. SERVICE SADDLES SHALL MEET AWWA C800.

NO.			REVISION			DATE			STANDARD DETAIL FOR PUBLIC WORKS CONSTRUCTION			SECTION: DOUGLAS COUNTY		
<h1>SERVICE SADDLE</h1> <h2>(3/4" - 2")</h2>									DATE:			JULY 2017		
									DWG:			B08		

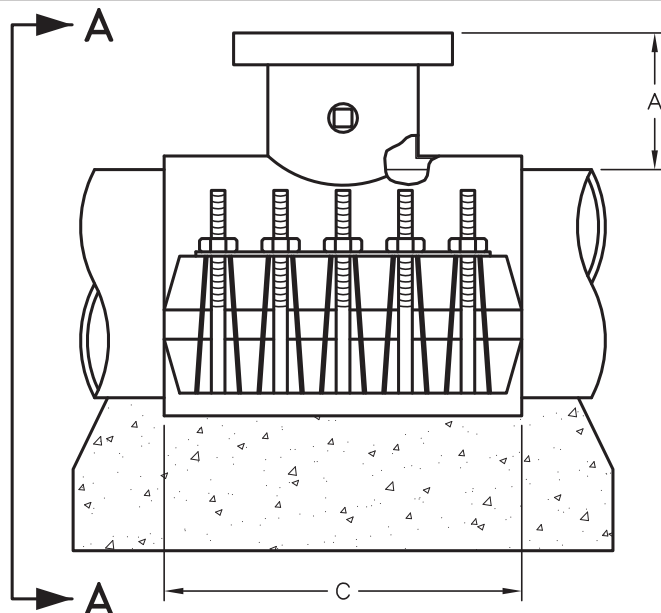

TYPICAL THRUST BLOCKING

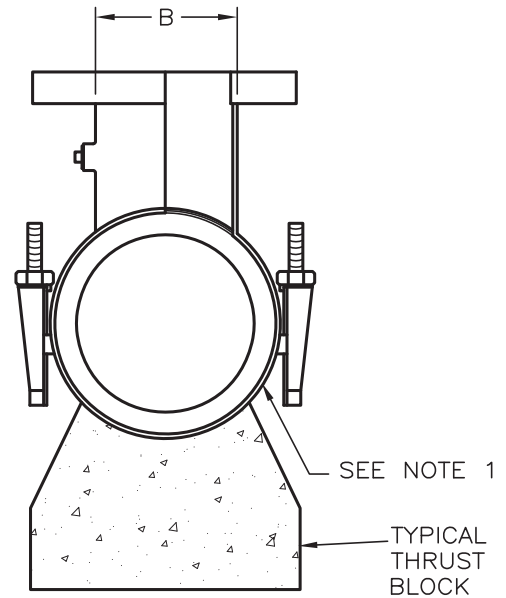

SECTION A-A

MATERIAL SPECIFICATIONS:

SHELL: 304 STAINLESS STEEL

LUGS: 304 STAINLESS STEEL

BOLTS, WASHERS AND NUTS: TYPE 304 STAINLESS STEEL, 5/8" DIAMETER.

GASKETS: NITRILE BUTADIENE RUBBER (NBR) FOR WATER SERVICE. ASTM D2000-MBC 610 FULL GASKET. 360° PIPE COVERAGE.

FLANGE: 304 STAINLESS STEEL OR HIGH TENSILE DUCTILE (NODULAR) IRON, ASTM A536-80, GRADE 65-45-12.

PRESSURE RATING:

- 200 PSI FOR 4-INCH THROUGH 8-INCH.
- 175 PSI OR HIGHER FOR 8-INCH THROUGH 24-INCH, OR AS APPROVED BY WATER UTILITY.

NOTES:

1. MATERIAL USED FOR THRUST BLOCKING SHALL NOT PREVENT ACCESS TO THE BOLT ASSEMBLY.
2. MINIMUM DISTANCE BETWEEN TAPS, COLLARS, JOINTS, SERVICE TAPS, ETC, SHALL BE 3 x DIA OF PIPE SIZE MIN.
3. SADDLE TO BE HYDROSTATICALLY TESTED PER MANUFACTURER'S RECOMMENDATIONS AND AWWA C223-02.
4. ANY HOT TAPS GREATER THAN 2-INCHES WILL BE BY AN APPROVED CONTRACTOR UNLESS WAIVED BY THE WATER UTILITY.
5. FOR FULL BODY TAPPING SLEEVES: MECHANICAL JOINT TAPPING SLEEVE SHALL BE DUCTILE IRON AND HAVE DI MECHANICAL JOINT END SEALS CONFORMING TO AWWA C111, WITH OUTLET FLANGE CONFORMING TO AWWA C207, CLASS D, WITH ANSI 150-LB DRILLING RECESSED FOR TAPPING SLEEVE. TAPPING SLEEVE SHALL FIT AWWA STANDARD 1908, CLASS AB-CD CAST IRON PIPE. MANUFACTURED BY CLOW, MUELLER, OR APPROVED EQUAL BY WATER UTILITY. ACCEPTABLE FOR CAST IRON AND DUCTILE IRON PIPE.
6. ON AC PIPE 2-INCH TAPPING SLEEVE REQUIRED DETAIL PER DESIGN ENGINEER, 2-INCH SERVICE SADDLE REQUIRED FOR ALL OTHER SERVICE LATERALS.

NOM. FLANGE	A	B	C	NO. BOLTS
4	4	5-1/32	16	10
6*	4-1/2	7-1/32	16	10
8*	4	9-1/32	20	14
10	5-1/2	11-1/32	24	16
12**	6-1/2	13-1/32	30	30

* TAPPING SLEEVES IN THE 24" NOMINAL PIPE SIZE RANGE WITH 6" OR 8" FLANGES ARE 24" LONG (C DIMENSION) AND HAVE 24" BOLTS.

** TAPPING SLEEVES IN THE 12" AND 14" NOMINAL PIPE SIZE RANGE WITH 12" FLANGE ARE 24" LONG AND HAVE 24" BOLTS.

NO.	REVISION	DATE	STANDARD DETAIL FOR PUBLIC WORKS CONSTRUCTION	SECTION: DOUGLAS COUNTY
			TAPPING SLEEVE	DATE: JULY 20173
				DWG: B09

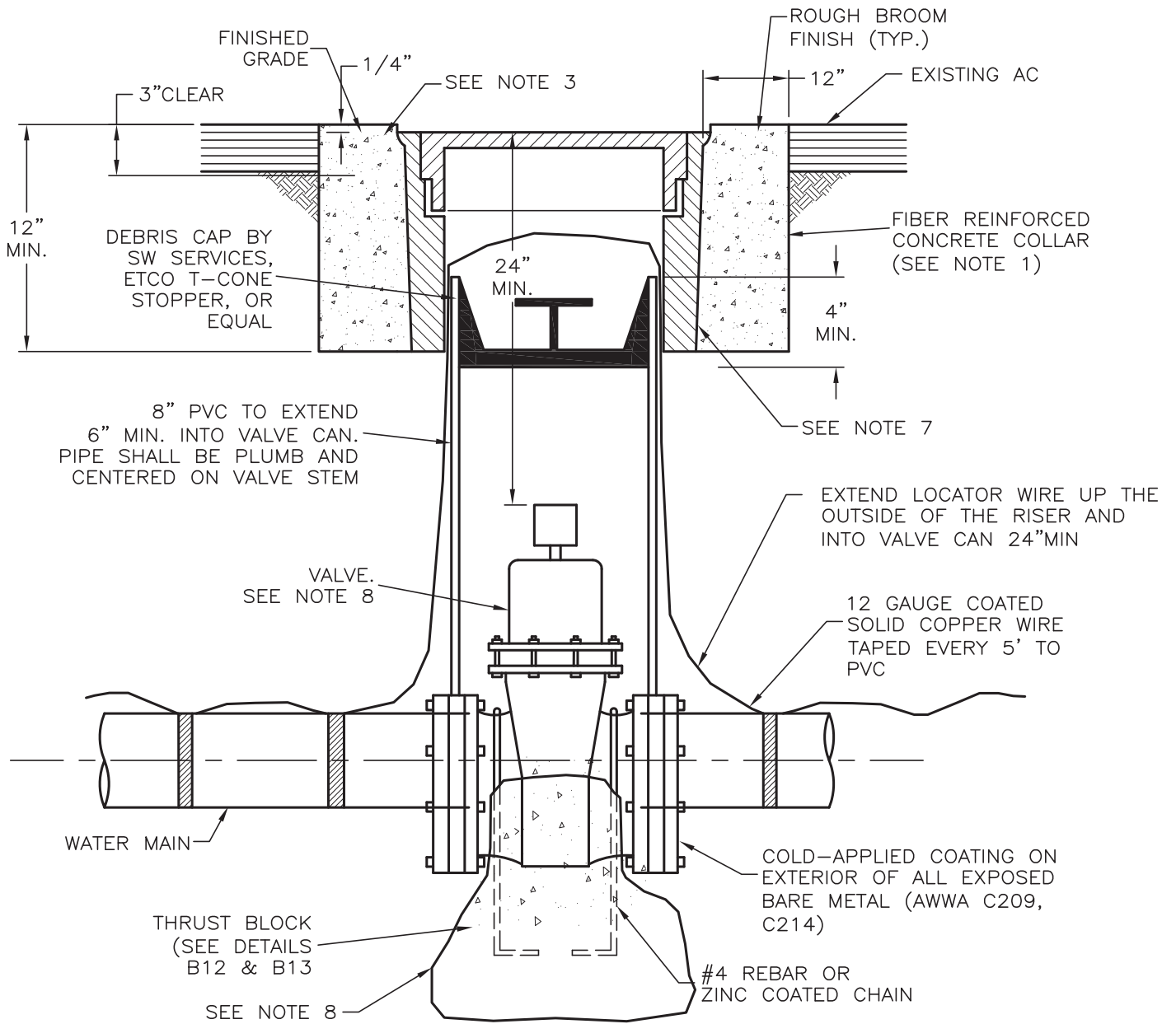

SEE NOTES ON PAGE 2

NO.	REVISION	DATE	STANDARD DETAIL FOR PUBLIC WORKS CONSTRUCTION	SECTION: DOUGLAS COUNTY
			VALVE	DATE: JULY 2017
				DWG: B10

NOTES:

1. CONCRETE SHALL MEET THE REQUIREMENTS OF SECTION 202.12 OF THE STANDARD SPECIFICATIONS FOR PUBLIC WORKS CONSTRUCTION.
2. IN ALL AREAS, LIDS SHALL BE SET FLUSH WITH FINISHED GRADE UNLESS OTHERWISE NOTED.
3. THE CONCRETE COLLAR SHALL BE 1/4" BELOW SURROUNDING PAVEMENT.
4. SPLICES IN WIRE SHALL BE CONNECTED BY WIRE NUTS AND WRAPPED WITH U/L LISTED ELECTRICAL TAPE, OR AS SPECIFIED BY WATER UTILITY.
5. THE CONTRACTOR SHALL PROVIDE AND INSTALL EXTENSION STEMS SO THAT VALVE OPERATING NUT IS NOT GREATER THAN 5 FEET BELOW FINISHED GRADE.
6. 10" VALVE BOX AND COVER MARKED "WATER" CHRISTY G-5 (AS APPROVED BY WATER UTILITY) WITH CAST IRON LID OR EQUAL. SEE "VALVE BOX" DETAIL B11.
7. VALVE:
 - FULL FLOW WATERWAY
 - O-RING SEAL
 - WEDGE DESIGN
 - FULL EPOXY COATING INSIDE AND OUT
 - OPERATOR NUT
 - 235 PSI RATING
 - STAINLESS STEEL BOLTS WITH BRONZE OR STAINLESS STEEL NUTS
 - LOW ZINC OR SS STEM
 - AWWA C509
 - RESILIENT WEDGE
8. THRUST BLOCK OR CONCRETE PILLOW WITH #4 REBAR OR ZINC COATED CHAIN MAY BE REQUIRED AT THE DISCRETION OF THE WATER UTILITY. MATERIAL USED FOR THRUST BLOCKING SHALL NOT PREVENT ACCESS TO THE BOLT ASSEMBLY.
9. THRUST BLOCK MAY BE ELIMINATED FOR FLANGED VALVES WITH MUELLER AQUAGRIP OR APPROVED EQUAL FLANGED RESTRAINT ADAPTOR, UNLESS CONSTRUCTING IN THE GARDNERVILLE WATER COMPANY SERVICE AREA.
10. RESTRAINTS PER ENGINEER'S DESIGN, BUT MANUFACTURER PARTS AS APPROVED BY WATER UTILITY.
11. ALL APPURTENANCES SHALL BE AS SPECIFIED, UNLESS APPROVED AS EQUAL BY WATER UTILITY.
12. VALVES LARGER THAN 12-INCH SHALL BE BUTTERFLY VALVES, OR AS APPROVED BY WATER UTILITY.

NO.	REVISION	DATE	STANDARD DETAIL FOR PUBLIC WORKS CONSTRUCTION	SECTION: DOUGLAS COUNTY
			VALVE	DATE: JULY 2017
				DWG: B10

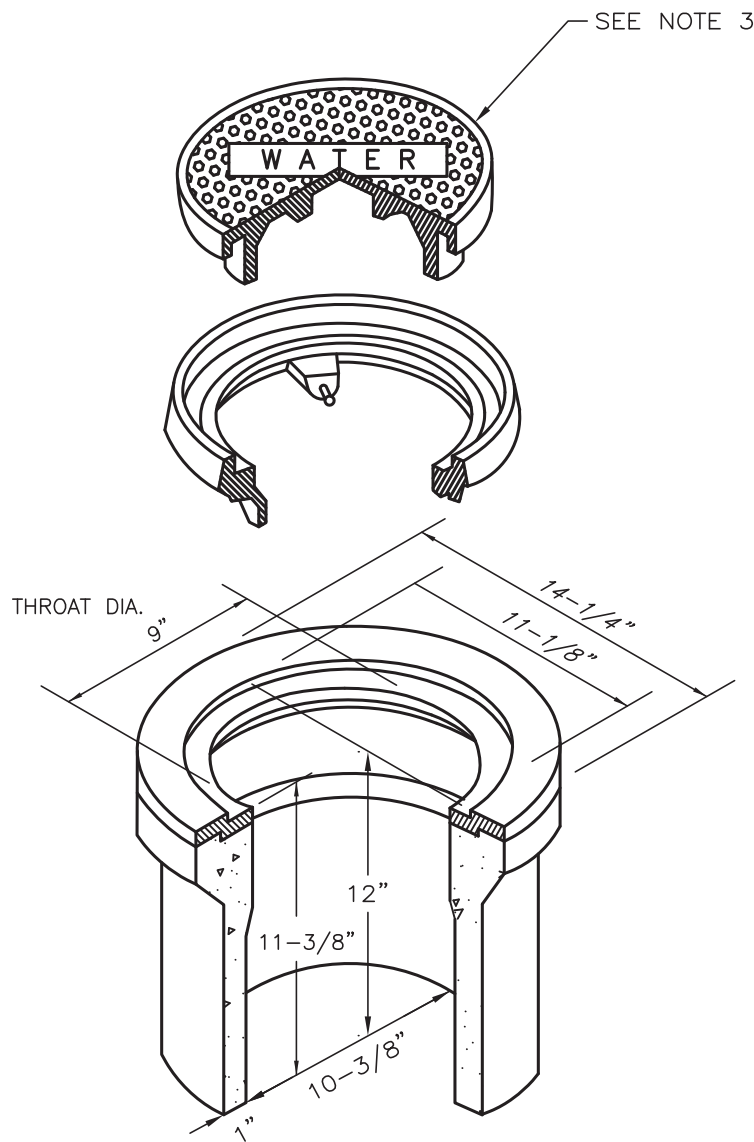

NOTES:

1. VALVE BOX MUST BE TRAFFIC RATED (CHRISTY G-5, AS APPROVED BY WATER UTILITY) WITH CAST IRON LID OR EQUAL.
2. MINIMUM OF 10 INCHES INSIDE DIAMETER.
3. CAST IRON LID MARKED "WATER" FOR WATER LINE APPLICATIONS. CAST IRON LID MARKED "RECLAIMED WATER" OR "RCW" WHEN INSTALLED ON A RECLAIMED WATER MAIN. CAST IRON LID SHALL BE MARKED "SS FORCE MAIN" OR "SS FM" WHEN INSTALLED ON A SANITARY SEWER FORCE MAIN.
4. RISER OF 8 INCHES PVC EXTENDED IN VALVE CAN A MINIMUM OF 6 INCHES.
5. ALL NEW VALVE BOXES TO BE SET TO GRADE PER "VALVE" DETAIL B10.
6. TORQUE GRADE RING BOLTS TO MANUFACTURER'S RECOMMENDATIONS.

NO.			REVISION			DATE			STANDARD DETAIL FOR PUBLIC WORKS CONSTRUCTION			SECTION: DOUGLAS COUNTY		
<h1>VALVE BOX</h1>									DATE:			JULY 2017		
									DWG:			B11		

Type of Fitting	90° Bend	45° Bend	11.25° or 22.5° Bend
Typical Installation			
Type of Fitting	Tee or Dead End	Cross w/Plug	Tee w/Plug
Typical Installation			

Minimum Thrust Block Bearing Area – Square Feet (Y x W)

Type of Fitting	90° Bend, Cross w/Plug or Tee w/Plug	45° Bend	11.25° or 22.5° Bend	Tee or Dead End
Size of Pipe	4"	2	1	2
	6"	5	3	4
	8"	8	5	6
	10"	13	7	9
	12"	18	10	13
	14"	25	13	17
	16"	32	17	23

NOTES:

1. CONCRETE FOR THRUST BLOCKS SHALL CONFORM TO SECTION 337.10 OF THE STANDARD SPECIFICATIONS FOR PUBLIC WORKS CONSTRUCTION AND SHALL HAVE A MINIMUM COMPRESSIVE STRENGTH OF 4000 PSI AT 28 DAYS.
2. THRUST BLOCKS SHALL BE PLACED AGAINST UNDISTURBED SOIL.
3. JOINTS AND FACE OF PLUGS SHALL BE KEPT CLEAR OF CONCRETE.
4. THRUST BLOCK BEARING AREAS ARE FOR A 160 PSI TEST PRESSURE WITH 2000 PSF BEARING CAPACITY, NOMINAL PIPE DIAMETER, AND A FACTOR OF SAFETY OF 1.5 INSTALLATIONS USING DIFFERENT TEST PRESSURES, AND/OR SOIL TYPES SHALL BE ADJUSTED BY THE DESIGN ENGINEER.
5. ALL JOINTS SHALL BE POLYWRAPPED (VIRGIN POLYETHYLENE, 8 MILS THICK).

NO.	REVISION	DATE	STANDARD DETAIL FOR PUBLIC WORKS CONSTRUCTION	SECTION: DOUGLAS COUNTY
			THRUST BLOCKS	DATE: JULY 2017
				DWG: B12

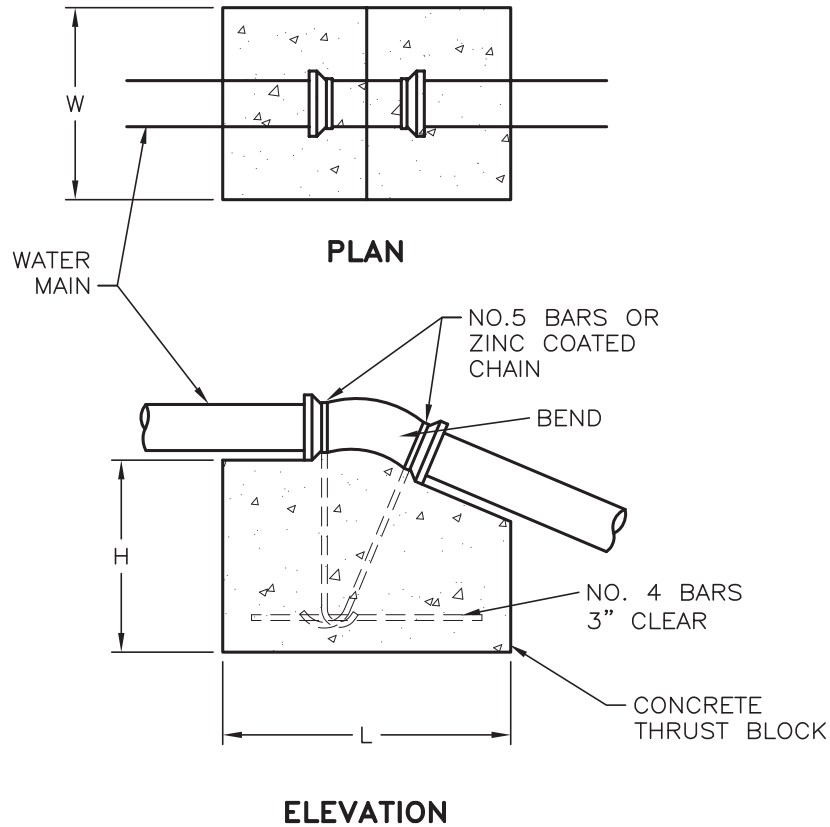

DIMENSIONS									
PIPE SIZE	11.25° BEND			22.5° BEND			45° BEND		
	L	W	H	L	W	H	L	W	H
6"	2'-0"	2'-0"	1'-6"	3'-0"	2'-0"	2'-0"	4'-0"	2'-0"	3'-6"
8"	3'-0"	3'-0"	2'-0"	4'-0"	2'-0"	3'-0"	6'-0"	2'-0"	4'-6"
10"	3'-0"	3'-0"	2'-0"	4'-0"	3'-0"	3'-0"	6'-0"	3'-0"	4'-6"
12"	4'-0"	4'-0"	2'-6"	6'-0"	3'-0"	3'-0"	7'-0"	4'-0"	4'-6"

NOTES:

1. CONCRETE FOR THRUST BLOCKS SHALL CONFORM TO SECTION 337.10 OF THE STANDARD SPECIFICATIONS FOR PUBLIC WORKS CONSTRUCTION AND SHALL HAVE A MINIMUM COMPRESSIVE STRENGTH OF 4000 PSI AT 28 DAYS.
2. REINFORCING STEEL SHALL BE ZINC COATED CHAINS OR NO. 5 REBAR.
3. VOLUMES GIVEN ARE FOR PIPE AT TEST PRESSURE 160 PSI AND NORMAL WEIGHT CONCRETE (145 LB / CUBIC FOOT). INSTALLATIONS USING DIFFERENT TEST PRESSURES OR WEIGHT OF CONCRETE SHOULD ADJUST VOLUMES ACCORDINGLY.
4. JOINT RESTRAINTS SHALL BE KEPT CLEAR OF CONCRETE.
5. ALL JOINTS SHALL BE POLYWRAPPED (VIRGIN POLYETHYLENE, 8 MILS THICK).

NO.	REVISION	DATE	STANDARD DETAIL FOR PUBLIC WORKS CONSTRUCTION	SECTION: DOUGLAS COUNTY
			THRUST BLOCK FOR UPWARD THRUST	DATE: JULY 2017
				DWG: B13

AVK SERIES 27 (NOSTALGIC STYLE) OR MUELLER A423 WITH (2) 2-1/2" OUTLETS AND (1) 4-1/2" OUTLET, SELF DRAINING BREAKAWAY TYPE, OR WATEROUS WB-67, OR PER WATER UTILITY

4" THICK CONCRETE COLLAR WITH FIBER MESH, SEE NOTE 10

FIRE HYDRANT INSTALLED SO AS TO PROVIDE A MIN. OF 3- FEET CLEARANCE IN ALL DIRECTIONS FROM FIRE HYDRANT. SEE DETAIL A THIS SHEET.

FLANGE 2" ABOVE FINISHED GRADE

BACK OF CURB

SEE "VALVE" DETAIL B10

SIDEWALK

PAVEMENT

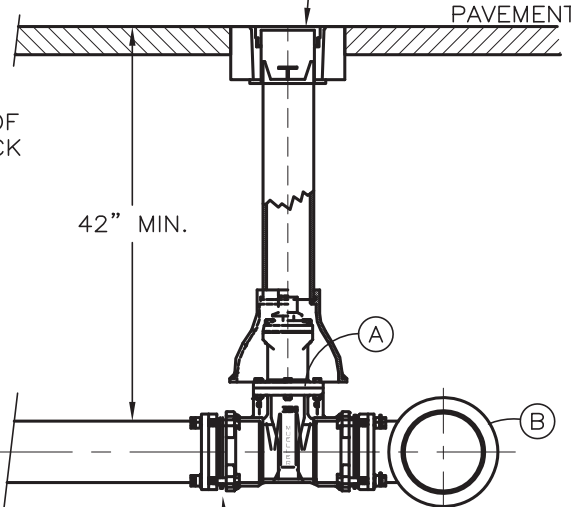
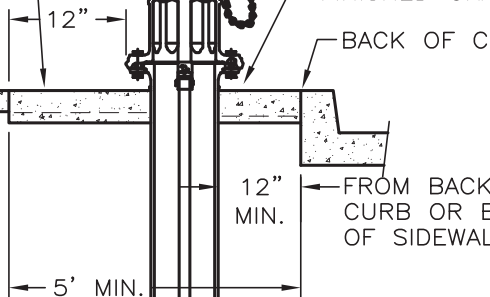

12" MIN. FROM BACK OF CURB OR BACK OF SIDEWALK

42" MIN.

6" MIN.

48" MIN.

MUELLER AQUAGRIP™ SHOE AN INTEGRAL RESTRAINT SYSTEM OR APPROVED EQUAL

CLEAN CRUSHED DRAIN ROCK 1/2" TO 2" (1 CU. YD.) MIN.

ALL JOINTS BETWEEN HYDRANT AND MAIN SHALL BE MECHANICALLY RESTRAINED

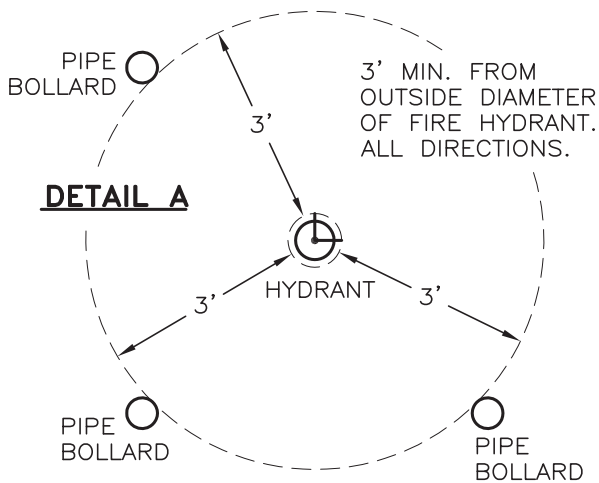

A. 6 INCH MUELLER GATE VALVE WITH 2 INCH SQUARE OPERATING NUT. SEE DETAIL B10.

B. FLANGE TEE DI ON NEW CONSTRUCTION. SEE "TAPPING SLEEVE" DETAIL B09 FOR EXISTING MAINS.

SEE NOTES ON PAGE 2

NO.	REVISION	DATE	STANDARD DETAIL FOR PUBLIC WORKS CONSTRUCTION	SECTION: DOUGLAS COUNTY
			FIRE HYDRANT ASSEMBLY	DATE: JULY 2017
				DWG: B14

NOTES:

1. HYDRANT COLOR SHALL BE AS APPROVED BY THE APPLICABLE FIRE DISTRICT.
2. OPERATING NUT SHALL BE 1-1/2" PENTAGON.
3. INSPECTION BY WATER UTILITY SHALL BE REQUIRED PRIOR TO BACKFILLING.
4. IN RESIDENTIAL AREAS, IF SIDEWALK NOT PRESENT, SET HYDRANT SO THAT OPERATING NUT IS 3'-6" BEHIND BACK OF CURB.
5. NO FENCES, LANDSCAPING OR ANY ABOVE GROUND IMPROVEMENTS SHALL BE ALLOWED WITHIN 3' OF THE OUTER MOST DIAMETER OF THE FIRE HYDRANT.
6. PROVIDE 42" MINIMUM COVER AT ROADSIDE DITCH FLOWLINE. LOCALIZED DIPPING OF WATER MAIN AT DITCH MAY NOT BE USED TO ACHIEVE 42" COVER.
7. GATE VALVE SHALL BE LOCATED WITHIN THE PAVEMENT, WHERE POSSIBLE.
8. FOR COMMERCIAL AND INDUSTRIAL PROPERTIES, OR WHEN THERE IS NO CURB, BOLLARDS SHALL BE ADDED PER "BOLLARD" DETAIL A20 WITH 3' CLEARANCE. SEE DETAIL A (SHEET 1/2).
9. THRUST BLOCK AND CONCRETE PILLOW WITH #4 REBAR OR ZINC COATED CHAIN MAY BE REQUIRED AT THE DISCRETION OF THE WATER UTILITY. MATERIAL USED FOR THRUST BLOCKING SHALL NOT PREVENT ACCESS TO THE BOLT ASSEMBLY.
10. 4" THICK CONCRETE COLLAR SHALL EXTEND OUT 12" FROM THE OUTER DIAMETER OF FIRE HYDRANT. THIS MAY CREATE A CONTINUOUS SECTION OF CONCRETE IN LANDSCAPE FINGERS AND SIMILAR AREAS. THE CONCRETE COLLAR IS NOT REQUIRED IN RESIDENTIAL SUBDIVISIONS WITH CURB AND GUTTER AND IS NOT REQUIRED IF BOLLARDS ARE INSTALLED.

NO.	REVISION	DATE	STANDARD DETAIL FOR PUBLIC WORKS CONSTRUCTION	SECTION: DOUGLAS COUNTY
			FIRE HYDRANT ASSEMBLY	DATE: JULY 2017
				DWG: B14

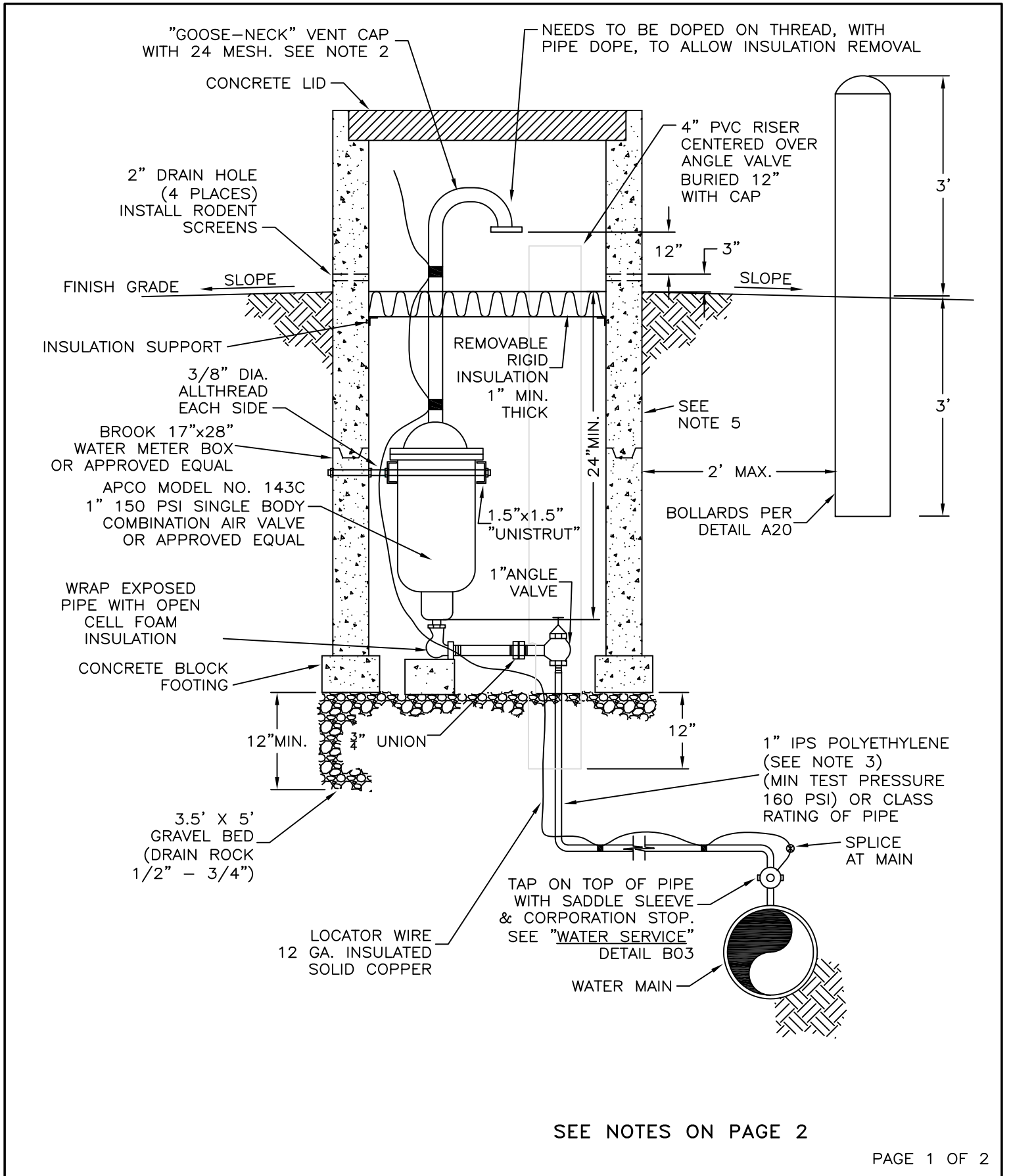

NO.	REVISION	DATE	STANDARD DETAIL FOR PUBLIC WORKS CONSTRUCTION	SECTION: DOUGLAS COUNTY
			<h1>COMBINATION AIR VALVE ASSEMBLY</h1>	DATE: DEC. 2018
				DWG: B15

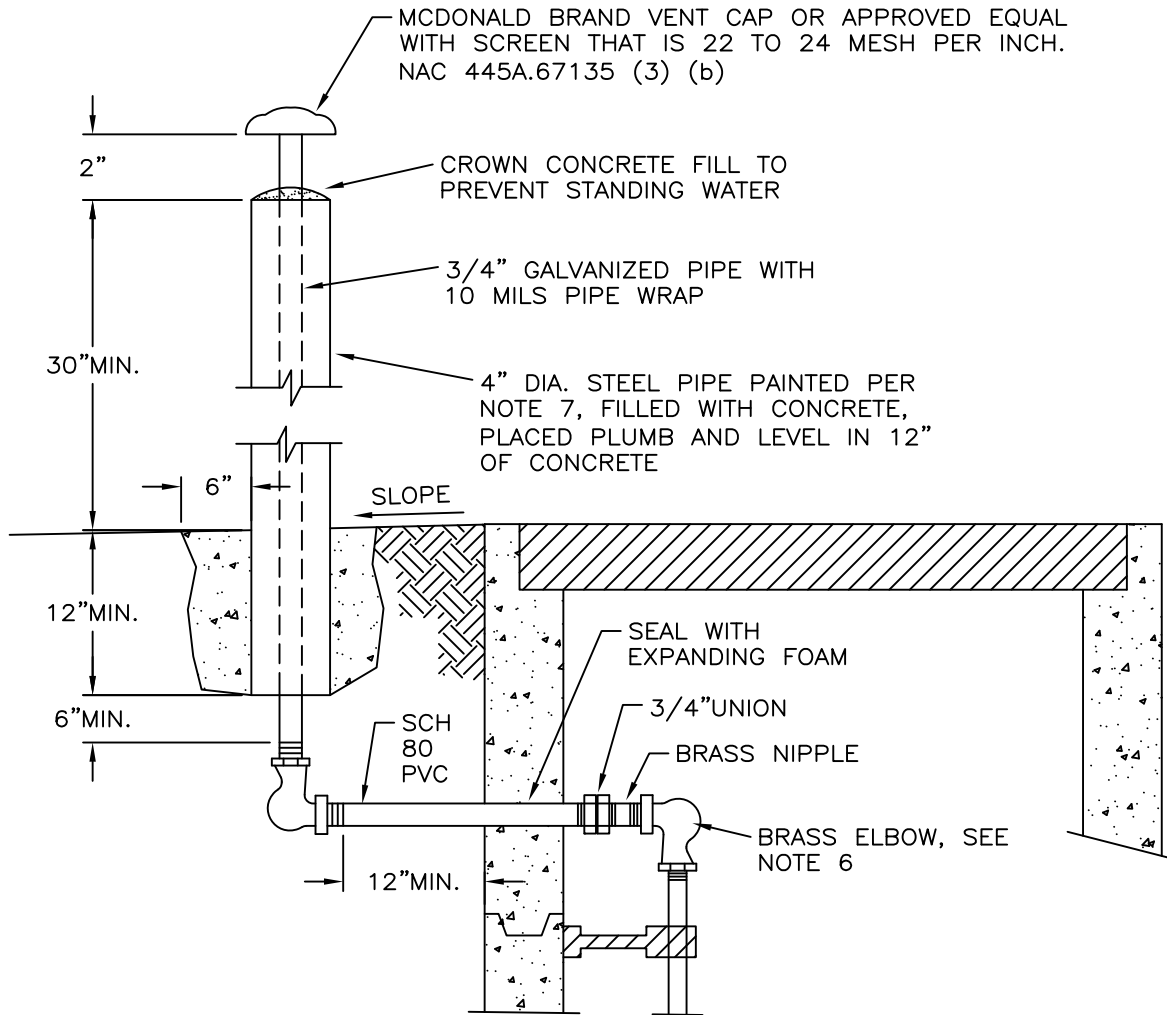

LAKE SCENARIO
OR AS APPROVED
BY WATER UTILITY

NOTES:

1. AIR RELEASE VALVES SHALL BE INSTALLED OUTSIDE PAVEMENT SECTION WHENEVER POSSIBLE. SLOPE GROUND AWAY FROM VALVE BOX OR CONSTRUCT CURBING TO PROTECT FROM FLOODING BY SURFACE DRAINAGE.
2. WHEN CONSTRUCTED IN STREET SECTION, CONSTRUCT AIR RELEASE BOX TO SIDE OF ROADWAY AND CONSTRUCT "GOOSE-NECK" ABOVE SURROUNDING GRADE AS DIRECTED BY CONSTRUCTION INSPECTOR.
3. CENTER OR SHIFT ASSEMBLY AS NECESSARY TO ALLOW FOR REMOVAL AND REPAIR. COORDINATE WITH WATER UTILITY.
4. ALL PIPES SHALL BE SLOPED UP TO AIR RELEASE VALVE.
5. INSULATE EXTERIOR OF BOX WITH 2" FOAM INSULATION, COVER WITH VISQUEEN BARRIER, BELOW GRADE.
6. STEEL PIPE PAINT SHALL BE RUST-OLEUM 7400 HIGH GLOSS SAFETY YELLOW ALKYD ENAMEL OR APPROVED EQUAL.

NO.	REVISION	DATE	STANDARD DETAIL FOR PUBLIC WORKS CONSTRUCTION	SECTION: DOUGLAS COUNTY
			<h1>COMBINATION AIR VALVE ASSEMBLY</h1>	DATE: DEC. 2018
				DWG: B15

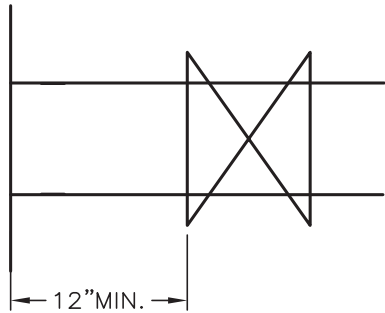
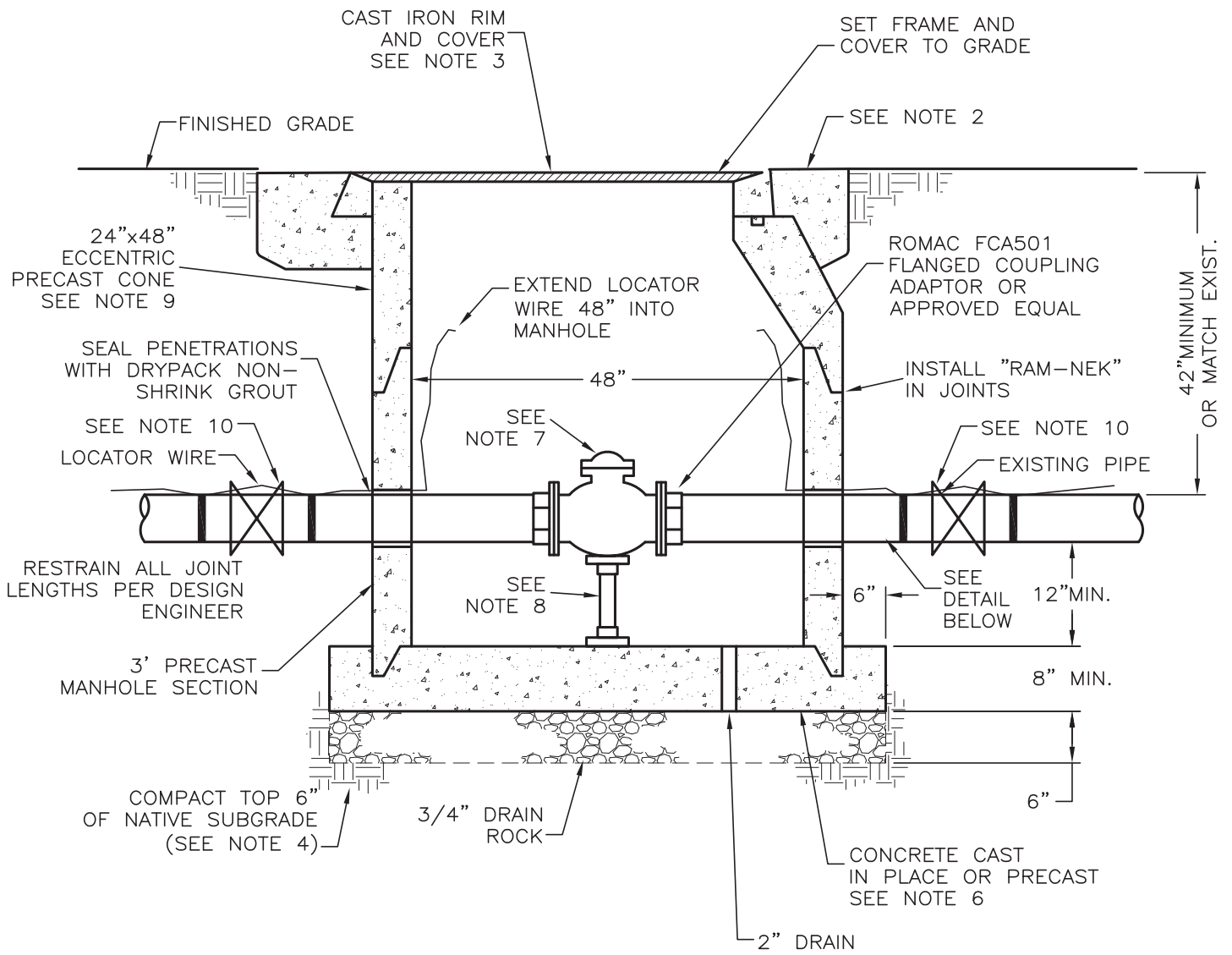

SEE NOTES ON PAGE 2

PAGE 1 OF 2

NO.	REVISION	DATE	STANDARD DETAIL FOR PUBLIC WORKS CONSTRUCTION	SECTION: DOUGLAS COUNTY
			<h1>CHECK VALVE</h1>	DATE: JULY 2017
				DWG: B16

NOTES:

1. CENTER CHECK VALVE IN VAULT.
2. MATCH ADJACENT PAVEMENT THICKNESS, NOT TO EXCEED 4".
3. MANHOLE FRAME AND COVER TO BE SOUTH BAY FOUNDRY SBF 1900 CLOSED PICK HOLE OR EQUAL AND COVER TO BE MARKED "WATER".
4. COMPACT NATIVE SUBGRADE IN CONFORMANCE WITH SECTION 302 OF THE STANDARD SPECIFICATIONS FOR PUBLIC WORKS CONSTRUCTION, PRIOR TO PLACING DRAINROCK.
5. CHECK VALVES 12 INCHES OR LARGER REQUIRE SPECIAL DESIGN AND APPROVAL OF THE WATER UTILITY.
6. CONCRETE SHALL CONFORM TO SECTION 202 OF THE STANDARD SPECIFICATIONS FOR PUBLIC WORKS CONSTRUCTION.
7. MUELLER FLG x FLG SWING CHECK VALVE OR APPROVED EQUAL.
8. 3 INCH GALVANIZED STEEL PIPE WITH THREADED FLANGES.
9. 24 INCH x 48 INCH ECCENTRIC PRECAST CONE (FOR CHECK VALVES 4 INCHES AND LESS). FOR VALVES GREATER THAN 4" DESIGN ENGINEER TO SPECIFY.
10. GATE VALVE, RISER PIPE, AND G-5 OR G-4 CHRISTY BOX AS APPROVED BY WATER UTILITY.
11. STEPS ARE REQUIRED WHERE MANHOLE DEPTH IS 54 INCHES (4'-6") OR GREATER, STEPS SHALL BE ALIGNED VERTICALLY (1 INCH MAXIMUM TOLERANCE) AND HORIZONTALLY (0.5 INCH TOLERANCE) SO AS TO FORM A CONTINUOUS LADDER, AND SHALL CONFORM WITH THE DESIGN REQUIREMENTS OF THE STATE OF NEVADA, OSHA STANDARDS, SECTION 1910.27 (DEPTH IS RIM ELEVATION TO TOP OF PIPE). STEPS SHALL BE STEEL REINFORCED POLYPROPYLENE.
12. CHECK VALVES 4 INCHES AND GREATER SHALL BE INSTALLED IN A VAULT WITH H2O TRAFFIC RATED LID AND LADDER.

NO.	REVISION	DATE	STANDARD DETAIL FOR PUBLIC WORKS CONSTRUCTION	SECTION: DOUGLAS COUNTY
			CHECK VALVE	DATE: JULY 2017
				DWG: B16

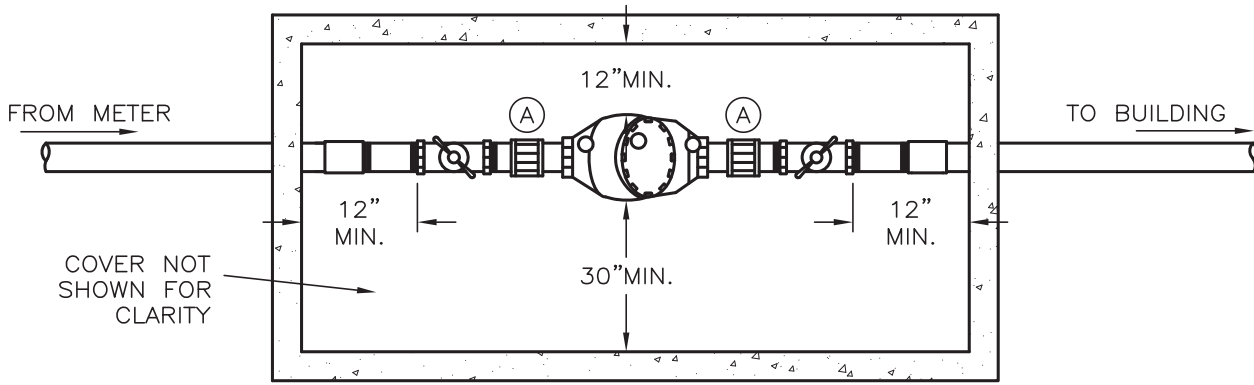

PLAN VIEW

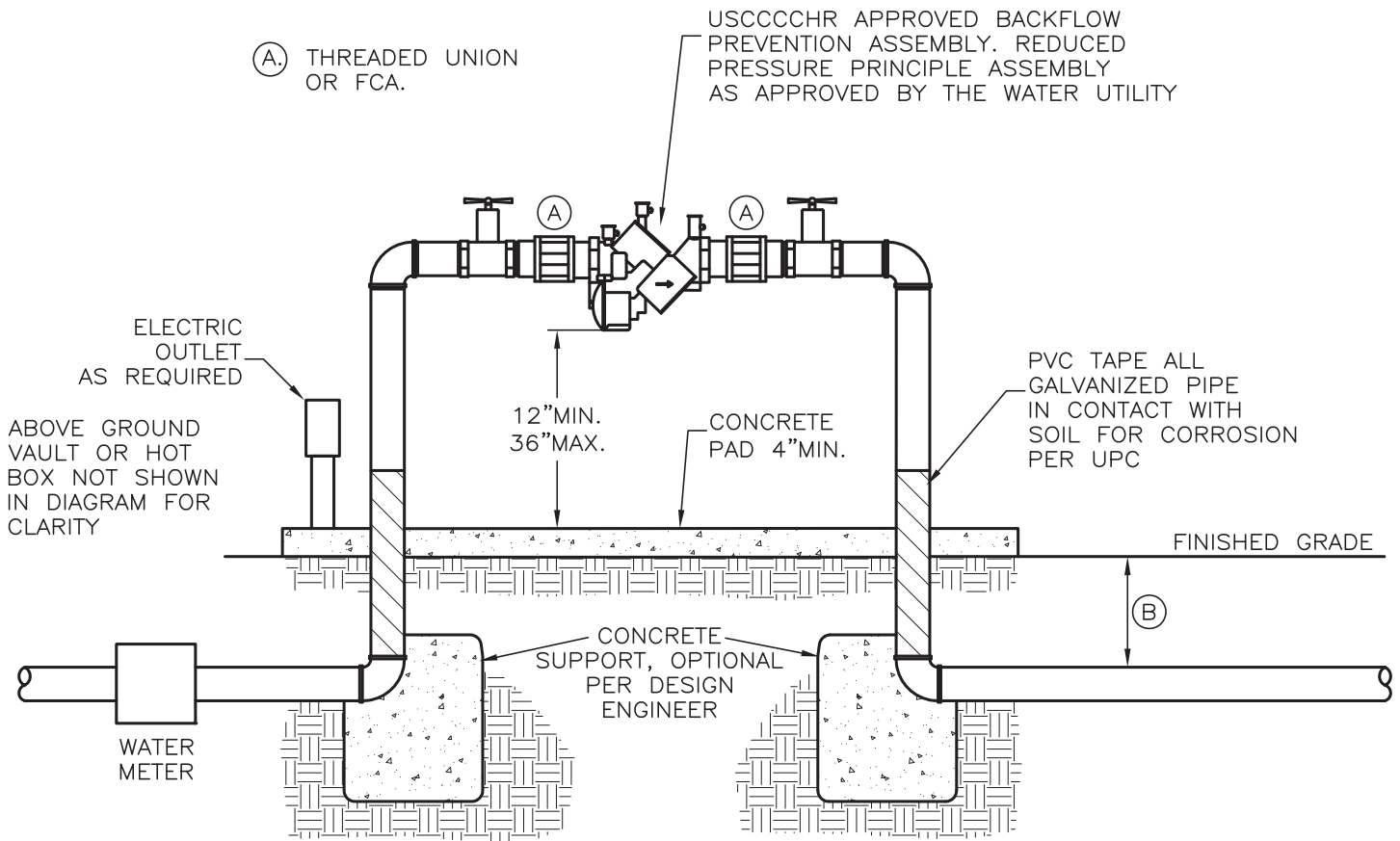

ELEVATION VIEW

(B) 30 INCHES MIN. PIPE DEPTH. USE TWO FULL TURNS OF TEFLON TAPE ON ALL THREADED JOINTS.

SEE NOTES ON PAGE 2

NO.	REVISION	DATE	STANDARD DETAIL FOR PUBLIC WORKS CONSTRUCTION	SECTION: DOUGLAS COUNTY
			BACKFLOW PREVENTION ASSEMBLY (RP)	DATE: JULY 2017
				DWG: B17

NOTES:

1. RP MUST BE ABOVE GRADE.
2. FREEZE PROTECTION (INSULATED ABOVE GROUND VAULT OR HOT BOX AND REDUNDANT HEAT TAPE) IS REQUIRED.
3. AN ABOVE GROUND VAULT (HOT BOX OR EQUIVALENT) MUST BE SIZED TO PROVIDE CLEARANCES SHOWN IN PLAN VIEW. A SPRING LOADED LID IS REQUIRED.
4. A HOT BOX LID MUST SWING CLEAR OF BACKFLOW PREVENTION ASSEMBLY TO PROVIDE CLEARANCES IN PLAN VIEW.
5. STOP AND WASTE VALVES MUST NOT BE USED BETWEEN THE METER AND THE BACKFLOW PREVENTION ASSEMBLY.
6. ABOVE GROUND VAULTS AND HOT BOX MUST PROVIDE ADEQUATELY SIZED DAYLIGHT DRAINS AT PAD LEVEL FOR DRAINAGE.
7. ELECTRICAL SUPPLY SOCKETS, IF REQUIRED, MUST BE AWAY FROM WATER RELIEF PORT AND TESTCOCKS, AND GFCI PROTECTED.
8. THE BACKFLOW PREVENTION ASSEMBLY DEVICE MUST BE VISUALLY INSPECTED BY A CALIFORNIA / NEVADA AWWA OR ABPA CERTIFIED BACKFLOW TESTER AT THE TIME OF INSTALLATION, YEARLY THEREAFTER, AND AFTER REPAIRS, WITH THE RESULTS SENT TO THE WATER UTILITY.
9. NO OUTLET TEE, TAP OR CONNECTION SHALL BE INSTALLED BETWEEN SERVICE CONNECTION AND BACKFLOW PREVENTION ASSEMBLY.
10. REFER TO RELIEF VALVE DISCHARGE RATE SO THAT ADEQUATE DRAINAGE CAN BE INSTALLED.
11. SUPPORTS REQUIRED FOR ASSEMBLIES 2.5" AND LARGER.
12. INDOOR INSTALLATION OF BACKFLOW PREVENTION ASSEMBLIES (RP's) SHALL MEET INSTALLATION CLEARANCES OF NAC 445A.67235(6).

NO.	REVISION	DATE	STANDARD DETAIL FOR PUBLIC WORKS CONSTRUCTION	SECTION: DOUGLAS COUNTY
			BACKFLOW PREVENTION ASSEMBLY (RP)	DATE: JULY 2017
				DWG: B17

ELEVATION VIEW

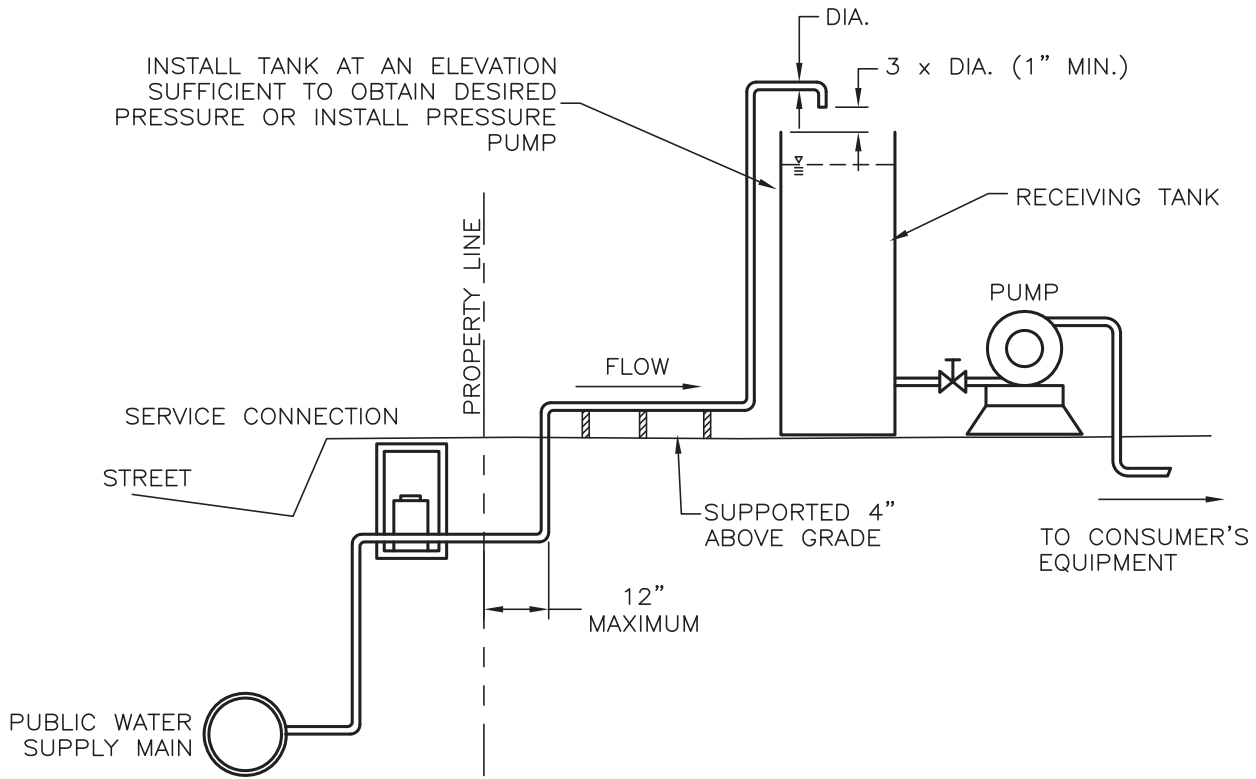

NOTES:

1. THE TANK SHOULD BE OF SUBSTANTIAL CONSTRUCTION AND OF A KIND AND SIZE TO SUIT CUSTOMER'S NEEDS. TANK MAY BE SITUATED AT GROUND LEVEL WITH A PUMP TO PROVIDE ADEQUATE PRESSURE OR BE ELEVATED ABOVE GROUND TO OBTAIN PRESSURE.
2. AN AIR GAP (VERTICAL PHYSICAL SEPARATION) OF AT LEAST 2 TIMES THE DIAMETER OF THE SUPPLY PIPE OR A MINIMUM OF 1 INCH MUST BE MAINTAINED BETWEEN THE LOWEST POINT OF THE SUPPLY PIPE AND THE WATER RECEIVING TANK.
3. FREEZE PROTECTION MUST BE PROVIDED FOR THE SUPPLY PIPE RISER THAT FILLS THE RECEIVING TANK AND THE TANK WHERE NECESSARY; DOMESTIC AND FIRE SERVICE MUST HAVE FREEZE PROTECTION, HOWEVER, IRRIGATION FREEZE PROTECTION IS OPTIONAL.
4. THE WATER METER WILL BE LOCATED UPSTREAM OF THE AIR GAP. NO OUTLET, TEE, TAP, CONNECTION TO OR FROM THE SERVICE LINE, OR STOP AND WASTE VALVE IS ALLOWED UPSTREAM ON THE AIR GAP ON THE SERVICE LINE.
5. IF THE AIR GAP IS INSTALLED IN AN AREA WHERE CORROSIVE FUMES OR GASES COULD RENDER THE ASSEMBLY INEFFECTIVE, A REDUCED PRESSURE PRINCIPLE MAY BE REQUIRED UPSTREAM.
6. THE AIR GAP MUST BE READILY ACCESSIBLE FOR VISUAL INSPECTION AND/OR UNIT REPAIR. ACCESS MAY REQUIRE THE REMOVAL OF AN ACCESS PANEL, DOOR, OR SIMILAR OBSTRUCTION.
7. THE AIR GAP MUST BE VISUALLY INSPECTED BY A CALIFORNIA/NEVADA AWWA OR ABPA CERTIFIED BACKFLOW TESTER AT THE TIME OF INSTALLATION, YEARLY THEREAFTER, AND AFTER REPAIRS, WITH THE RESULTS SENT TO THE WATER UTILITY.
8. THE AIR GAP MUST REMAIN OPERATIVE AND EFFECTIVE THROUGHOUT THE YEAR WITHOUT BEING BYPASSED. THE WATER UTILITY MUST BE NOTIFIED OF ANY BYPASSES USED FOR WHATEVER REASON.

NO.	REVISION	DATE	STANDARD DETAIL FOR PUBLIC WORKS CONSTRUCTION	SECTION: DOUGLAS COUNTY
			AIR GAP SEPARATION	DATE: JULY 2017
				DWG: B18

FOR ADOPTION AT A LATER DATE

DETAIL CONTINUED ON PAGE 2

SEE NOTES ON PAGE 3

PAGE 1 OF 3

NO.	REVISION	DATE	STANDARD DETAIL FOR PUBLIC WORKS CONSTRUCTION	SECTION: DOUGLAS COUNTY
			PRESSURE REDUCING STATION	DATE: JULY 2017
				DWG: B19

FOR ADOPTION AT A LATER DATE

DETAIL CONTINUED FROM PAGE 1

SEE NOTES ON PAGE 3

PAGE 2 OF 3

NO.	REVISION	DATE	STANDARD DETAIL FOR PUBLIC WORKS CONSTRUCTION	SECTION:
			PRESSURE REDUCING STATION	DOUGLAS COUNTY
				DATE: JULY 2017
				DWG: B19

FOR ADOPTION AT A
LATER DATE

NO.	REVISION	DATE	STANDARD DETAIL FOR PUBLIC WORKS CONSTRUCTION	SECTION: DOUGLAS COUNTY
			PRESSURE REDUCING STATION	DATE: JULY 2017
				DWG: B19

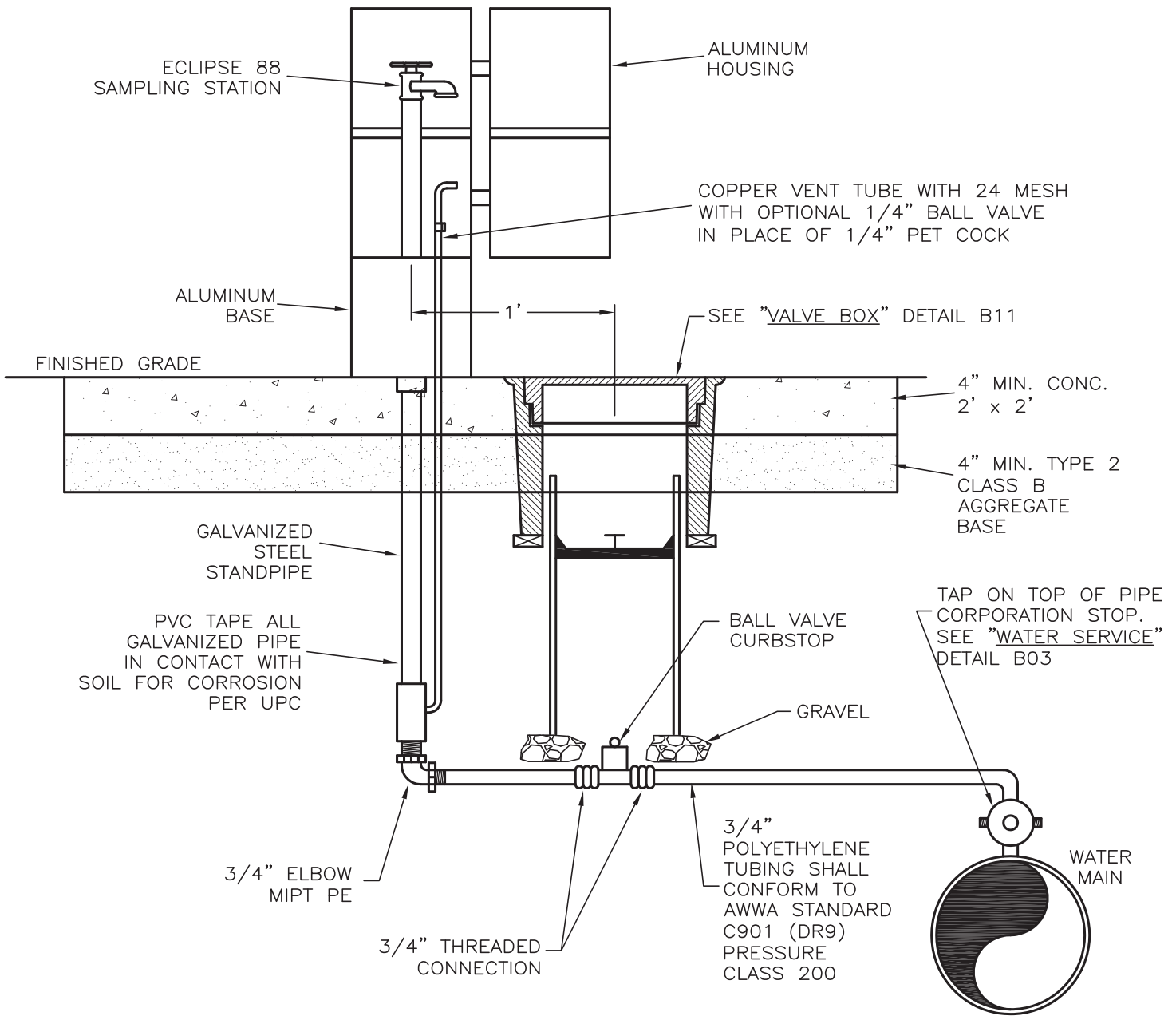

NOTES:

1. SAMPLING STATIONS SHALL BE 42" BURY, WITH 3/4" FIP INLET, AND 3/4" HOSE OR UNTHREADED NOZZLE.
2. ALL STATIONS SHALL BE ENCLOSED IN A LOCKABLE, NON-REMOVABLE, ALUMINUM-CAST HOUSING.
3. WHEN OPENED, THE STATION SHALL REQUIRE NO KEY FOR OPERATION, AND THE WATER WILL FLOW IN AN ALL BRASS WATERWAY.
4. ALL WORKING PARTS WILL ALSO BE OF BRASS AND BE REMOVABLE FROM ABOVE GROUND WITH NO DIGGING.
5. A COPPER VENT TUBE WILL ENABLE EACH STATION TO BE PUMPED FREE OF STANDING WATER TO PREVENT FREEZING AND TO MINIMIZE BACTERIAL GROWTH.
6. ECLIPSE No. 88 SAMPLING STATION SHALL BE MANUFACTURED BY KUPFERLE FOUNDRY, ST. LOUIS, MO, 63102.
7. THE SAMPLE TAP SHALL BE "SMOOTH NOSED".

NO.	REVISION	DATE	STANDARD DETAIL FOR PUBLIC WORKS CONSTRUCTION	SECTION: DOUGLAS COUNTY
			ECLIPSE No. 88 SAMPLING STATION	DATE: JULY 2017
				DWG: B20

WATER UTILITY GENERAL NOTES:

1. ALL WORK SHALL CONFORM TO THE STANDARD SPECIFICATIONS FOR PUBLIC WORKS CONSTRUCTION AS ADOPTED BY DOUGLAS COUNTY. THE OWNER / CONTRACTOR SHALL OBTAIN A PERMIT FROM DOUGLAS COUNTY COMMUNITY DEVELOPMENT PRIOR TO THE START OF CONSTRUCTION.
2. ALL TRAFFIC CONTROL AND BARRICADING WITHIN THE PUBLIC RIGHT-OF-WAY SHALL CONFORM TO PART VI OF THE MANUAL ON UNIFORM TRAFFIC CONTROL DEVICES, LATEST EDITION, AND THE NEVADA WORK ZONE TRAFFIC CONTROL HANDBOOK, 1986 EDITION. NO STREET CLOSURES WILL BE ALLOWED WITHOUT PRIOR WRITTEN APPROVAL OF A TRAFFIC CONTROL PLAN BY THE DOUGLAS COUNTY ENGINEERING DIVISION.
3. THE OWNER / CONTRACTOR SHALL CALL UNDERGROUND SERVICE ALERT "CALL BEFORE YOU DIG" 1-800-227-2600 FORTY-EIGHT (48) HOURS PRIOR TO START OF CONSTRUCTION. AN UNDERGROUND SERVICE ALERT MAY ALSO BE LOGGED AT WWW.USANORTH.ORG.
4. THE OWNER / CONTRACTOR SHALL CALL DOUGLAS COUNTY ENGINEERING DIVISION (782-6237) FORTY-EIGHT (48) HOURS PRIOR TO START OF CONSTRUCTION. THE OWNER / CONTRACTOR SHALL CALL TWENTY-FOUR (24) HOURS PRIOR TO REQUIRED INSPECTIONS AND TESTING. THE REQUIRED INSPECTIONS AND TESTING ARE LISTED ON THE INSPECTION RECORD ISSUED WITH EACH PERMIT. THE OWNER / CONTRACTOR MUST HAVE THE PERMIT NUMBER AND THE DESCRIPTION LISTED ON THE INSPECTION RECORD TO SCHEDULE REQUIRED INSPECTIONS AND TESTING.
5. THE APPROVED PLAN, PERMIT AND INSPECTION RECORD MUST BE ON THE JOB SITE AT ALL TIMES.
6. WATER MAIN SHUTDOWNS / INTERRUPTION OF SERVICE: WATER UTILITY APPROVAL IS REQUIRED FORTY-EIGHT (48) HOURS PRIOR TO NOTIFICATION OF CUSTOMERS. COMMERCIAL AND RESIDENTIAL CUSTOMERS SHALL BOTH RECEIVE FORTY-EIGHT (48) HOURS WRITTEN NOTICE OF A SHUTDOWN, AND SPECIAL ARRANGEMENTS MAY HAVE TO BE MADE TO ACCOMMODATE CUSTOMERS OPERATIONAL NEEDS. THE WATER UTILITY IS RESPONSIBLE FOR THE NOTIFICATION WHEN WORK IS PERFORMED BY THE WATER UTILITY. THE CONTRACTOR IS RESPONSIBLE IN ALL OTHER CASES. A LIST SHALL BE KEPT BY THE RESPONSIBLE PARTY LISTING THE DATE, TIME, AND ADDRESS OF ALL PERSONS NOTIFIED. THE PERSON NOTIFIED SHALL BE INCLUDED ON THE LIST FOR ALL COMMERCIAL CUSTOMERS. THE CONTRACTOR WILL BE SUBJECT TO DAMAGE CLAIMS SHOULD THEY FAIL TO NOTIFY CUSTOMERS OR MAINTAIN DOCUMENTATION OF NOTIFICATION OF CUSTOMERS. THE CONTRACTOR SHALL NOT OPERATE ANY EXISTING WATER VALVES WITHOUT AUTHORIZATION OF THE WATER UTILITY.
7. ALL WATER MAINS SHALL BE C900, C905, DUCTILE IRON, AS SPECIFIED ON THE PLANS OR AS APPROVED BY THE WATER UTILITY. ALL WATER SERVICES 2" OR LESS SHALL BE IPS, PE PIPE (AWWA STANDARD C901); SERVICES 3" OR GREATER SHALL BE CLASS 150 C900 PVC OR AS SPECIFIED ON THE PLANS.
8. LINE SEPARATION MUST MEET THE PROVISIONS OF NAC 445A.6715 THROUGH 445A.6718 IN ITS ENTIRETY, NDEP'S VERTICAL CROSSING SUMMARY, AND BE APPROVED BY STATE AND WATER UTILITY.
9. ALL HOT TAPS ARE TO BE PERFORMED BY A LICENSED CONTRACTOR APPROVED BY THE WATER UTILITY. THE CONTRACTOR SHALL CONTACT THE WATER UTILITY AT LEAST FORTY-EIGHT (48) HOURS PRIOR TO SCHEDULING HOT TAP DATE AND TIME.
10. WATER VALVE MARKERS SHALL BE BLUE CARSONITE UTILITY MARKER (CRM-3066), 5'-2" WITH WATER UTILITY'S DECAL OR APPROVED EQUAL. PLACE MARKER NO MORE THAN FIVE (5) FEET FROM THE VALVE OR AS DIRECTED BY THE WATER UTILITY.
11. ALL WATER MAIN AND WATER SERVICE INSPECTIONS MUST BE COMPLETED PRIOR TO ANY CERTIFICATE OF OCCUPANCY OR NOTICE OF COMPLETION BY THE WATER UTILITY ACCEPTING IMPROVEMENTS.

NO.	REVISION	DATE	STANDARD DETAIL FOR PUBLIC WORKS CONSTRUCTION	SECTION: DOUGLAS COUNTY
			WATER UTILITY GENERAL NOTES	DATE: JULY 2017
				DWG: B21



Appendix C

Sewer System Details

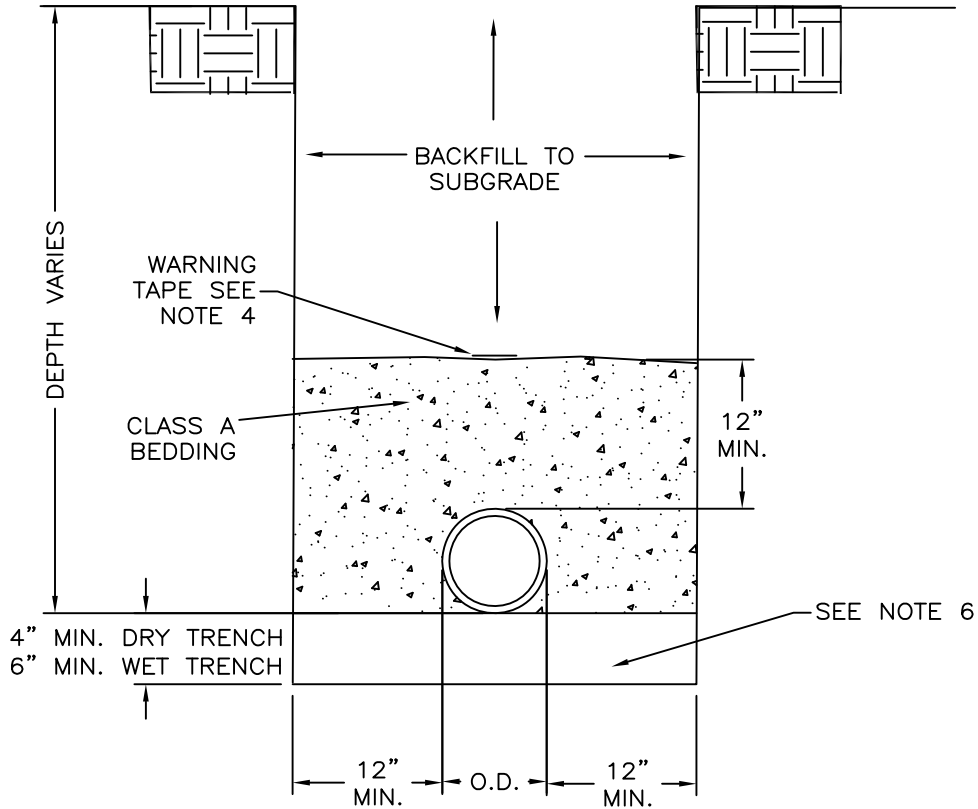

THE FOLLOWING GRADED BEDDING MATERIAL MAY BE USED IN WET TRENCHES:

U.S. STANDARD SIEVE SIZE	PERCENT BY WEIGHT PASSING
1.5"	100%
1"	50-90%
3/4"	30-70%
3/8"	10-40%
#4	5-25%
#200	0-10%

CLASS A BACKFILL PER ORANGE BOOK 200.03.02 USED AS BEDDING MATERIAL MUST BE USED IN DRY TRENCHES ONLY, SEE NOTE 6.

SEE NOTES ON PAGE 2

PAGE 1 OF 2

NO.	REVISION	DATE	STANDARD DETAIL FOR PUBLIC WORKS CONSTRUCTION	SECTION: DOUGLAS COUNTY
			TYPICAL SEWER TRENCH	DATE: DEC 2018
				DWG: C01

NOTES:

1. ALL REQUIREMENTS OF THE SEWER UTILITY ORDINANCE, APPENDIX D SEWER FACILITIES ORDINANCE FROM TITLE 20, MUST BE MET.
2. ANY VARIATION IN BEDDING GRADATIONS SHALL ONLY BE ALLOWED IF GRADATION OF ALTERNATIVE MATERIAL IS SUBMITTED TO AND APPROVED BY THE COUNTY ENGINEER OR SEWER UTILITY PRIOR TO CONSTRUCTION.
3. CLASS A AND CLASS E BACKFILL AND BEDDING MATERIAL SHALL CONFORM TO SECTION 200 OF THE STANDARD SPECIFICATIONS FOR PUBLIC WORKS CONSTRUCTION. BEDDING AND BACKFILL SHALL BE MECHANICALLY COMPACTED OR CONSOLIDATED IN CONFORMANCE WITH SECTION 305 OF THE STANDARD SPECIFICATIONS FOR PUBLIC WORKS CONSTRUCTION.
4. PLACE WARNING TAPE 1-FOOT ABOVE SEWER PIPE. WARNING TAPE SHALL READ "CAUTION SEWER MAIN".
5. SEWER PIPE COLOR SHALL BE GREEN FOR GRAVITY SEWER AND PURPLE FOR RECLAIMED WATER.
6. BEDDING MATERIAL SHALL BE PER ORANGE BOOK 200 COMPACT OR CONSOLIDATE TO PROVIDE PROPER SUPPORT OF PIPE.
7. FOR STRUCTURAL (PAVEMENT) SECTION, SEE "STREET CUT REPAIR" DETAIL A14.

FORCE MAIN NOTES:

1. FORCE MAIN BEDDING MATERIAL SHALL CONFORM TO THE REQUIREMENTS OF CLASS A BACKFILL AS SPECIFIED IN SUBSECTION 200.03.02 OF THE ORANGE BOOK. MATERIAL SHALL BE DENSIFIED TO 90% RELATIVE COMPACTION.
2. BACKFILL SHALL CONFORM TO THE REQUIREMENTS OF CLASS E BACKFILL AS SPECIFIED IN SUBSECTION 200.03.06 OF THE ORANGE BOOK. MATERIAL SHALL BE PLACED IN LIFT THICKNESS SPECIFIED IN SUBSECTION 305 OF THE ORANGE BOOK AND DENSIFIED TO 90% RELATIVE COMPACTION.
3. PLACE WARNING TAPE 1-FOOT ABOVE THE FORCE MAIN. WARNING TAPE SHALL READ "CAUTION FORCE MAIN".
4. FORCE MAIN SHALL HAVE A MINIMUM OF 4 FEET OF COVER MEASURED FROM FINISHED GRADE TO TOP OF PIPE.

NO.	REVISION	DATE	STANDARD DETAIL FOR PUBLIC WORKS CONSTRUCTION	SECTION: DOUGLAS COUNTY
			TYPICAL SEWER TRENCH	DATE: DEC 2018
				DWG: C01

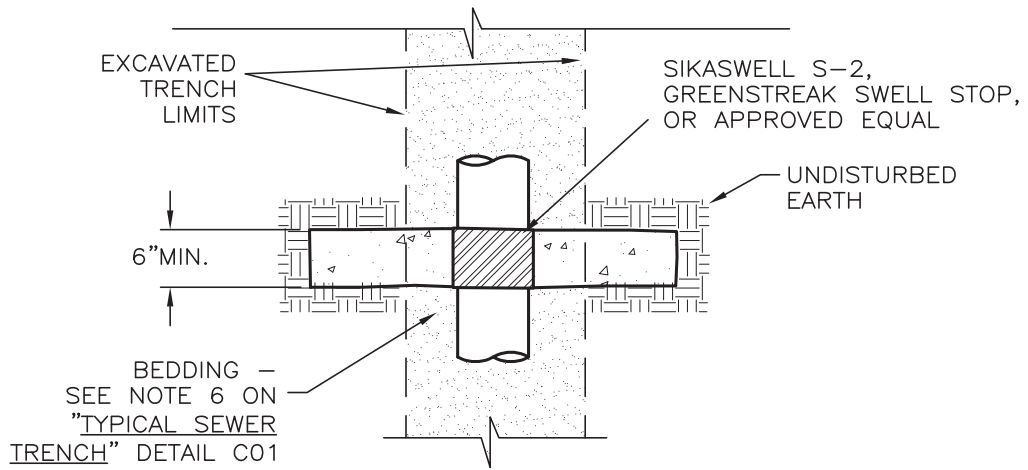

PLAN

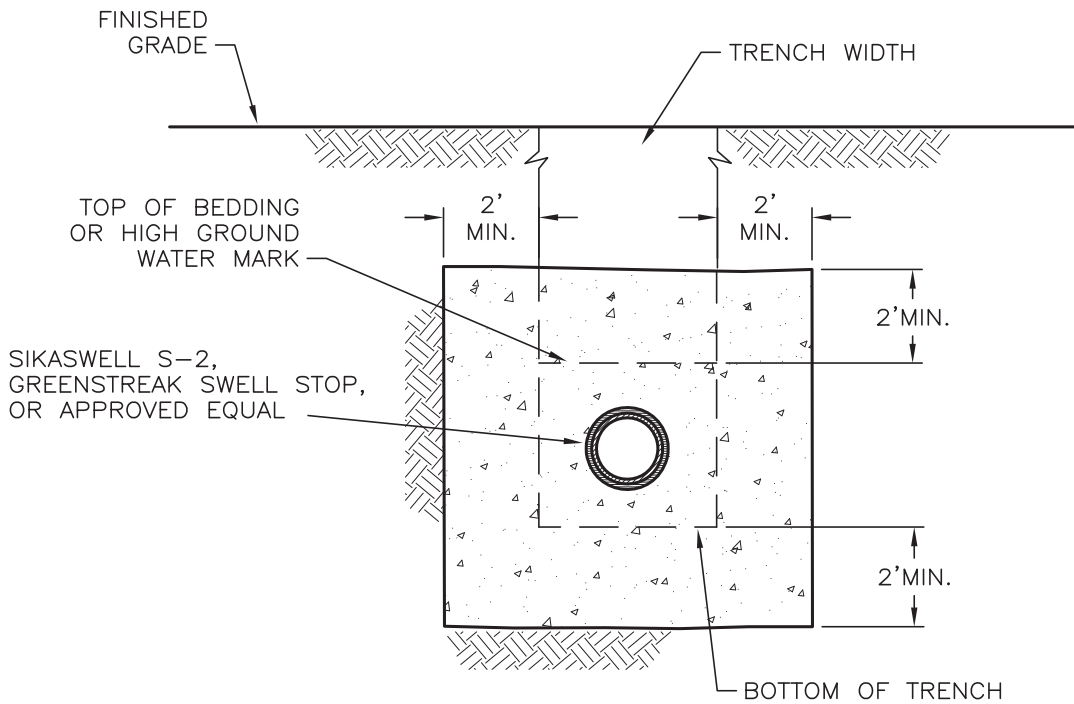

SECTION

NOTES:

1. WATER STOPS SHALL BE CONSTRUCTED AT 200-FOOT MAXIMUM SPACING IN GROUND WATER CONDITIONS AND WHERE WET TRENCH BEDDING IS USED, ONLY AS DIRECTED BY SEWER UTILITY BASED ON SLOPE.
2. WRAP PIPE WITH SIKASWELL S-2, OR GREENSTREAK SWELL STOP, OR EQUIVALENT WHERE PIPE IS EXPOSED TO CONCRETE PRIOR TO POURING.
3. USE LIGHT CONCRETE TYPE A SLURRY BACKFILL PER ORANGE BOOK 337.08.01-1. IF CEMENT BOARD IS USED FOR CONCRETE FORMS, IT MAY BE LEFT IN PLACE.

NO.	REVISION	DATE	STANDARD DETAIL FOR PUBLIC WORKS CONSTRUCTION	SECTION: DOUGLAS COUNTY
			WATER STOP	DATE: JULY 2017
				DWG: C02

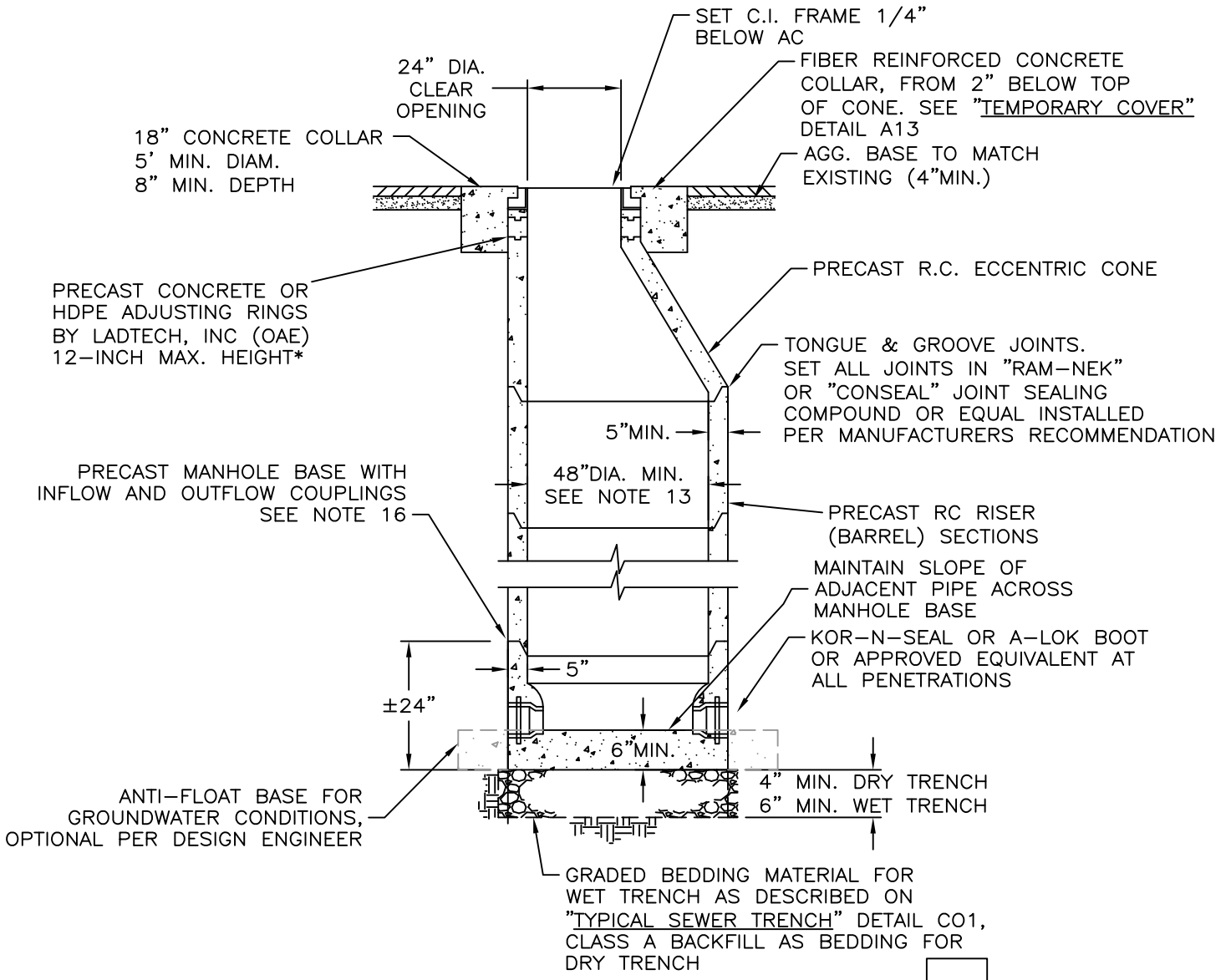

TYPICAL SECTION

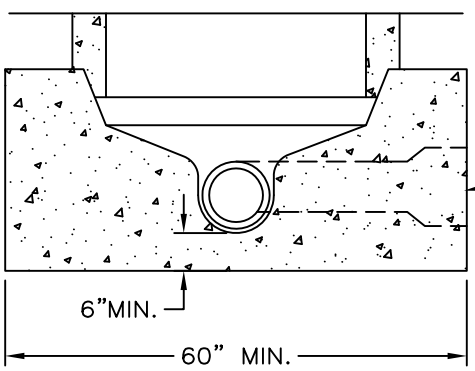

SIDE VIEW SECTION

SMALLER MAIN SEWER FLOW CHANNELS ARE TO BE BROUGHT INTO MAIN LINE CHANNELS WITH THE ELEVATION OF PIPE CROWN THE SAME.

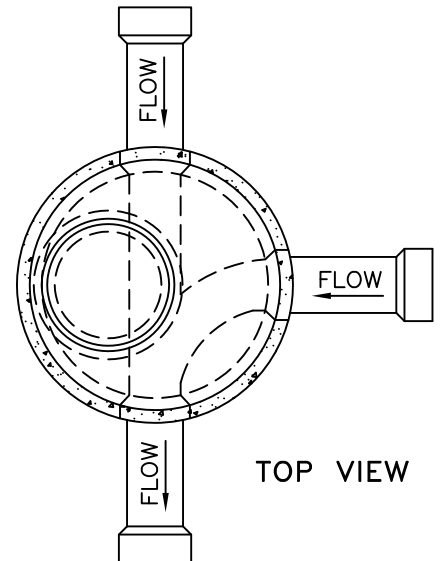

TOP VIEW

* NO WOOD OR PVC SHIMS WILL BE ALLOWED BETWEEN LID RING AND AJUSTING RING OR MANHOLE WITH LADTECH SYSTEM

NO.	REVISION	DATE	STANDARD DETAIL FOR PUBLIC WORKS CONSTRUCTION	SECTION: DOUGLAS COUNTY
			<h1>SANITARY SEWER MANHOLE</h1>	DATE: DEC. 2018
				DWG: C03

NOTES:

1. CONTRACTOR SHALL CONTACT AND COORDINATE WITH THE SEWER UTILITY AND ALL OTHER UTILITIES 48 HOURS PRIOR TO CONSTRUCTION.
2. ALL CONSTRUCTION SHALL CONFORM TO SEWER UTILITY'S STANDARDS AND NO BACKFILLING WILL BE ALLOWED UNTIL INSPECTED AND APPROVED.
3. MANHOLE SHALL BE CONSTRUCTED OF PRECAST REINFORCED CONCRETE SECTIONS CONFORMING TO ASTM DESIGNATION C478 WET CAST ONLY.
4. EXCAVATION FOR MANHOLE MUST BE MADE TO A MINIMUM OF 1-FOOT OUTSIDE OF THE MANHOLE WALL TO PROVIDE FOR ADEQUATE WORKSPACE. SPACE OUTSIDE OF THE MANHOLE SHALL BE BACKFILLED WITH ACCEPTABLE MATERIAL IN UNIFORM LAYERS NOT EXCEEDING 12-INCHES IN DEPTH. EACH LAYER SHALL BE THOROUGHLY COMPACTED TO THE DENSITY OF THE EARTH IN THE ADJACENT TRENCH SECTIONS. (MIN. 90% IN EXISTING OR PROPOSED STREET OR ALLEY RIGHTS-OF-WAY).
5. CAST IRON FRAME AND COVER SHALL BE 24-INCH DIAMETER (CLEAR OPENING) AND SHALL BE MANUFACTURED FROM GRAY CAST IRON CONFORMING TO ASTM DESIGNATION: A 48, CLASS 30 AND DESIGNED FOR A MINIMUM HS-20 TRAFFIC LOADING. COVERS AND FRAMES SHALL BE MATCH-MARKED IN PAIRS AND SEATING SURFACES MACHINED SO THAT COVER IS NON-ROCKING. COVERS SHALL HAVE ONE PICK HOLE, AND ONE CENTRALLY LOCATED 1-INCH DIG HOLE. COVERS SHALL HAVE NO "THRU" HOLES.
6. ALL BASES MUST BE PRECAST UNLESS OTHERWISE APPROVED BY THE SEWER UTILITY.
7. CONCRETE FOR CAST-IN-PLACE MANHOLE BASE, IF APPROVED BY THE SEWER UTILITY FOR USE, SHALL CONFORM TO SECTION 202 OF THE STANDARD SPECIFICATIONS FOR PUBLIC WORKS CONSTRUCTION.
8. SEWER STUBS FOR FUTURE EXTENSION SHALL BE NO MORE THAN 5- FEET IN LENGTH.
9. THE TOP OF INCOMING LATERAL SEWERS SHALL ENTER THE MANHOLE AT AN ELEVATION EQUAL TO THE TOP OF THE MAIN LINE. EXCEPTIONS ONLY BY PRIOR SEWER UTILITY APPROVAL.
10. INVERTS SHALL BE FORMED DIRECTLY IN CONCRETE OF MANHOLE BASE AND SHALL BE SMOOTH AND ACCURATELY SHAPED TO A SEMI-CIRCULAR BOTTOM CONFORMING TO THE INSIDE OF THE ADJACENT SEWER SECTION. MAINTAIN SLOPE OF ADJACENT PIPELINE ACROSS THE MANHOLE BASE.
11. WHERE MANHOLES ARE NOT LOCATED IN STREETS, PLACE TOP OF MANHOLE 8-INCHES ABOVE THE EXISTING GROUND UNLESS OTHERWISE REQUIRED BY THE SEWER UTILITY. INSTALL THE CONCRETE COLLAR FROM A POINT 6-INCHES OUTSIDE THE TOP OF THE COVER FRAME AND EXTEND A MINIMUM OF 12-INCHES BELOW THE SURROUNDING GROUND SURFACE. TAPER THE CONCRETE COLLAR FROM TOP TO BOTTOM AT A 1:1 SLOPE OR FLATTER.
12. PROVIDE 60-INCH MINIMUM DIAMETER MANHOLE FOR PIPES LARGER THAN 15-INCH DIAMETER.
13. COAT EXTERIOR OF MANHOLE WHERE GROUNDWATER CONDITIONS ARE PRESENT AS APPROVED BY SEWER UTILITY.
14. ALL MANHOLES SHALL BE VACUUM TESTED FROM TOP OF CONE PRIOR TO PAVING.
15. POLYMER MANHOLES SHALL BE REQUIRED AT ALL FORCE MAIN OUTLETS. POLYMER MANHOLES SHALL BE INSTALLED DOWNSTREAM OF MANHOLE WHERE FORCE MAIN CONVERTS TO GRAVITY FLOW. ONE POLYMER MANHOLE FOR EVERY 1-INCH DIAMETER SIZE OF THE FORCE MAIN.
16. PIPE INVERT ELEVATIONS SHALL BE A MINIMUM OF 0.1 FEET ABOVE OUTFLOW PIPE ELEVATIONS FOR STRAIGHT FLOW THROUGH OR 0.2 FEET FOR 90 DEGREE BEND FLOW THROUGH.

NO.	REVISION	DATE	STANDARD DETAIL FOR PUBLIC WORKS CONSTRUCTION	SECTION: DOUGLAS COUNTY
			<h1 style="margin: 0;">SANITARY SEWER MANHOLE</h1>	DATE: DEC. 2018
				DWG: C03

3" OR 6" ADJUSTING GRADE RING, MAX HEIGHT 12", AS REQUIRED TO MEET STREET ELEVATION

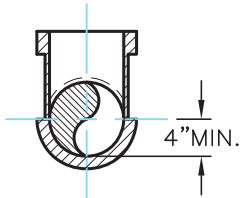

SECTION B-B
NTS

60" DIA. MIN. MANHOLE. SEE NOTE 2

ANTI-FLOAT BASE FOR GROUNDWATER CONDITIONS, OPTIONAL PER DESIGN ENGINEER

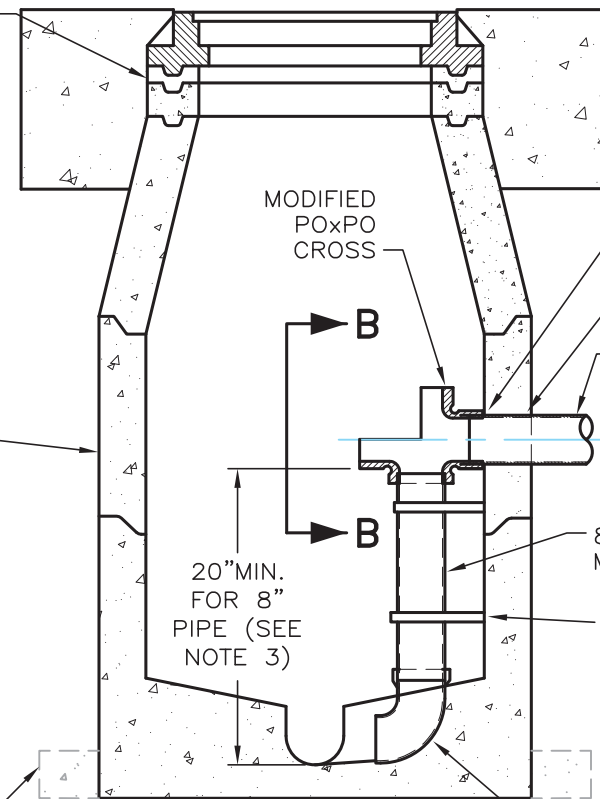

SECTION A-A
NTS

FIBER REINFORCED CONCRETE COLLAR FULL DEPTH. SET $\frac{1}{4}$ " BELOW FINISHED GRADE SEE "TEMPORARY COVER" DETAIL A13 IF NEEDED

CORE DRILL MANHOLE WHEN CONNECTING TO AN EXISTING SEWER MAIN
WATERTIGHT SEAL, LINK SEAL WITH STAINLESS STEEL BOLTS OR APPROVED EQUAL

SANITARY SEWER 8" MIN.

8" MIN. SDR 35 PIPE. MATCH INCOMING PIPE SIZE.

PIPE STRAP (SEE DETAIL). PLACE AT TOP, BOTTOM, AND 18" O.C. BETWEEN. MINIMUM 2 REQUIRED PER INSTALLATION. ATTACH TO BARREL WITH $\frac{1}{4}$ " ϕ x 3" STAINLESS STEEL ANCHOR BOLTS.

MANUFACTURER TO FORM INVERT TROUGH TO ACCEPT PVC ELBOW (AS SIZED PER PLANS)

SLOPE MANHOLE BASE. SEE NOTE 2.

60" DIA. MIN. MANHOLE AND BASE. SEE NOTE 2.

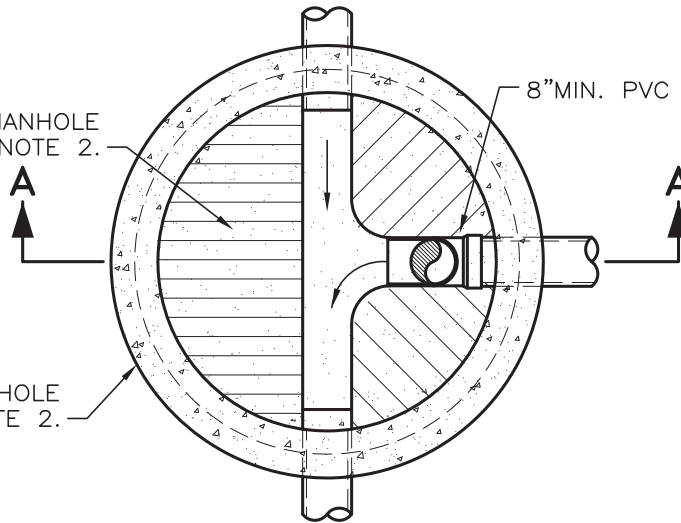

PLAN VIEW
NTS

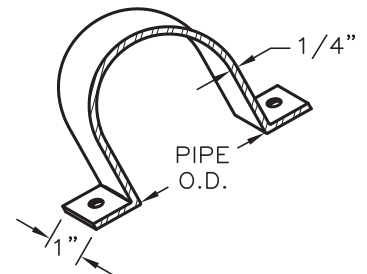

STRAP MATERIAL SHALL BE STAINLESS STEEL OR HIGH GRADE ALUMINUM

PIPE STRAP DETAIL
NTS

NOTES:

1. USE OF A DROP MANHOLE REQUIRES APPROVAL FROM DOUGLAS COUNTY ENGINEER OR SEWER UTILITY.
2. SEE SANITARY SEWER MANHOLE DETAIL C03 FOR ADDITIONAL NOTES, DIMENSIONS AND DETAILS.
3. PROVIDE ADEQUATE PIPE LENGTH TO ALLOW FOR REMOVAL OF MODIFIED CROSS.
4. DROP MANHOLE FOR USE ONLY IN GRAVITY SEWER SYSTEMS.

NO.			REVISION			DATE			STANDARD DETAIL FOR PUBLIC WORKS CONSTRUCTION			SECTION: DOUGLAS COUNTY		
<h1>DROP MANHOLE</h1>									DATE:			JULY 2017		
									DWG:			C04		

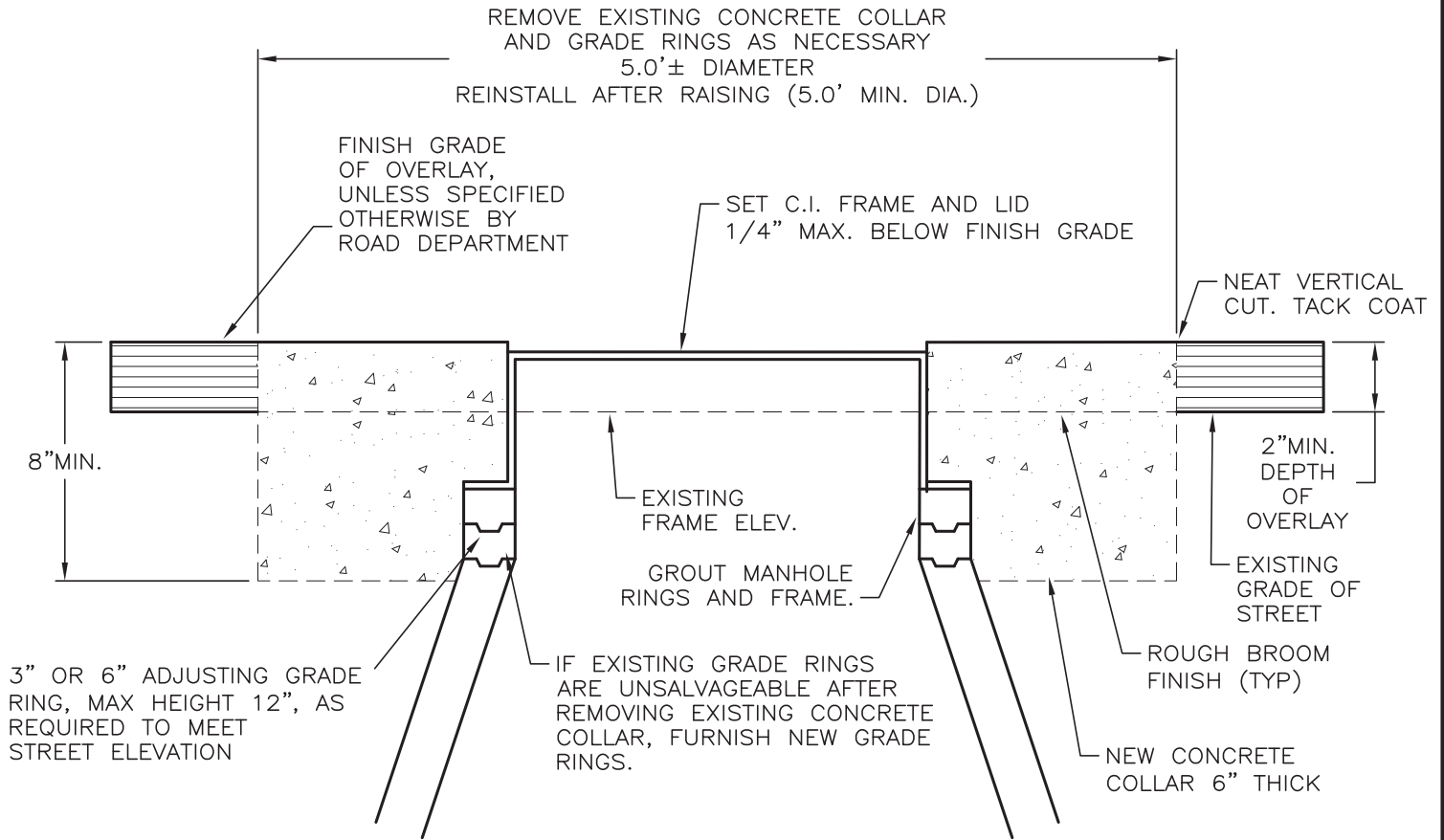

NOTES:

1. CONCRETE SHALL BE FIBER REINFORCED 4000 PSI AT 28 DAYS MIX.
2. CONTRACTOR MAY RAISE LIDS BEFORE OR AFTER OVERLAY AT HIS OPTION.
3. IF NEW BARREL SECTION IS ADDED ALL WORK SHALL CONFORM TO SANITARY SEWER MANHOLE DETAIL C03.
4. CONTRACTOR SHALL MAINTAIN MANHOLE AND SEWER LINES FREE OF DEBRIS AT ALL TIMES.
5. GRADE RINGS SHALL BE PRECAST CONCRETE OR HDPE LADTECH INSTALLED PER MANUFACTURER'S SPECIFICATIONS. WOOD SHIMS ARE NOT ALLOWED WITH LADTECH SYSTEMS.
6. VACUUM TESTING NOT REQUIRED ON EXISTING MANHOLES.

NO.			REVISION			DATE			STANDARD DETAIL FOR PUBLIC WORKS CONSTRUCTION			SECTION: DOUGLAS COUNTY		
									<h1>SANITARY SEWER MANHOLE RAISING</h1>			DATE: JULY 2017		
												DWG: C05		

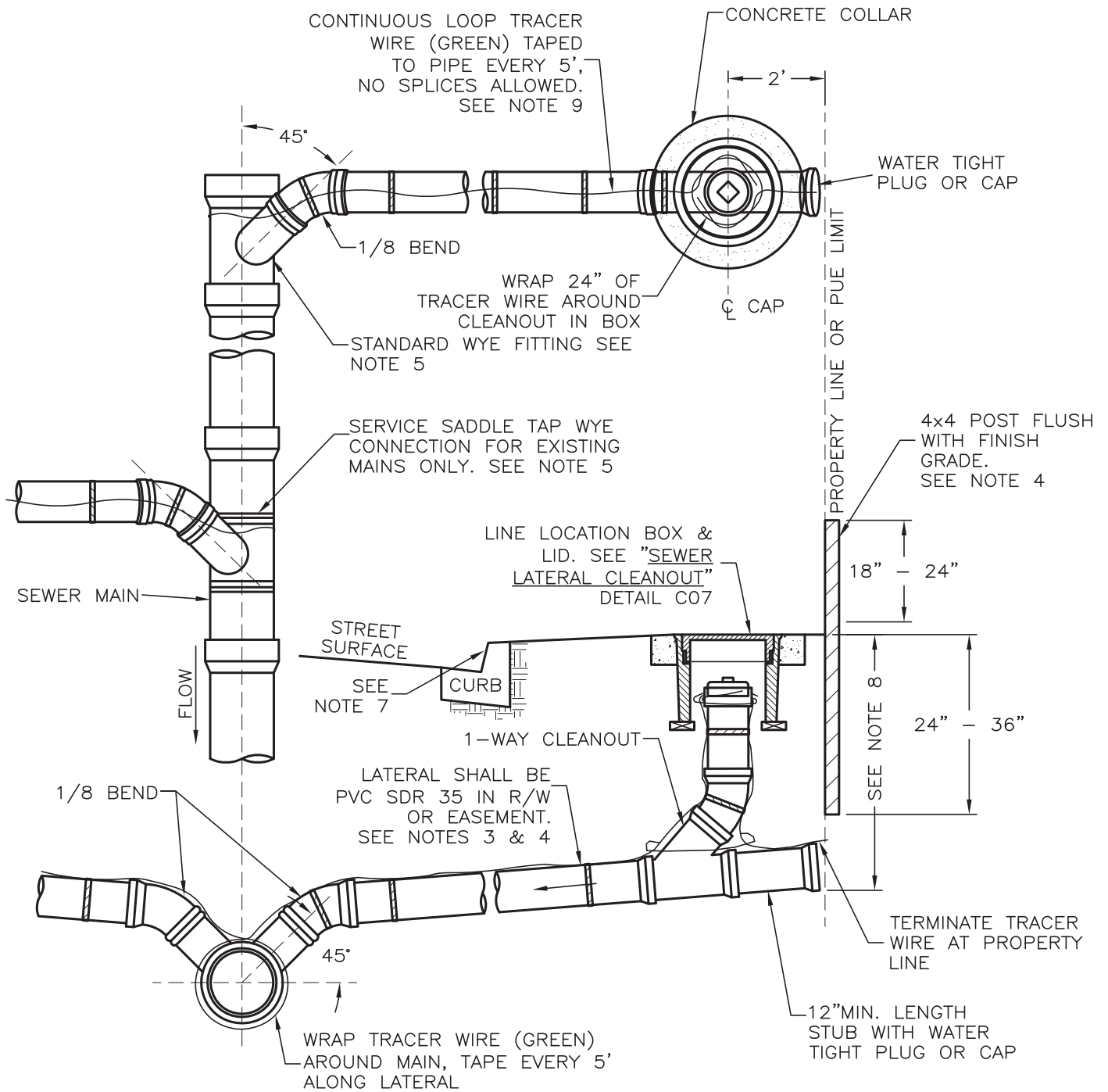

TYPICAL SECTION

SEE NOTES ON PAGE 2

NO. REVISION DATE			STANDARD DETAIL FOR PUBLIC WORKS CONSTRUCTION		SECTION: DOUGLAS COUNTY	
			<h1>SEWER LATERAL</h1>		DATE: JULY 2017	
					DWG: C06	

NOTES:

1. IN NO CASE SHALL A LATERAL CONNECT TO THE SEWER MAIN DIRECTLY ON TOP OR MATCH THE FLOWLINE OF THE PIPE.
2. SEWER LATERALS SHALL HAVE A MINIMUM SLOPE OF 2% ON 4" LATERAL AND 1% ON 6" LATERAL. PLANS SHALL INDICATE INVERT ELEVATION REQUIRED TO SERVE PROPERTY AND CLEAR UNDERGROUND OBSTRUCTIONS.
3. ALL JOINTS ON SEWER LATERAL PIPE WITHIN THE RIGHT-OF-WAY SHALL BE COMPRESSION TYPE. C900 PVC MAY BE SUBSTITUTED FOR SDR 35 TO MEET NDEP BSDW SEPARATIONS.
4. LATERAL (EXCEPT IN CUL-DE-SACS) SHALL BE PERPENDICULAR TO THE MAIN AND EXTEND TO PROPERTY LINE OR PUE LIMITS. IF INSTALLING LATERAL PRIOR TO THE PUBLIC MAIN , INSTALLATION OF THE LATERAL SHALL BE EXTENDED TO PUBLIC UTILITY EASEMENT LINE AND A STANDARD WATERTIGHT PLUG OR CAP AND REDWOOD POST SHALL BE INSTALLED AT EASEMENT LINE.
5. USE OF SEWER SERVICE TAP SADDLE CONNECTIONS SHALL NOT BE ALLOWED FOR NEW SEWER MAIN CONSTRUCTION. WHEN A TAP SADDLE CONNECTION IS TO BE USED ON AN EXISTING SEWER MAIN, IT SHALL BE A WYE SADDLE AND BE INSTALLED PER "SEWER SERVICE SADDLE" DETAIL C08.
6. DISCONTINUANCE OF USE OF AN EXISTING SEWER LATERAL REQUIRES ABANDONMENT OF THE LATERAL. CUT, REMOVE 1 FOOT OF EXISTING LATERAL, AND CAP BOTH ENDS OF THE EXISTING SEWER LATERAL TO BE ABANDONED WITHIN 6 INCHES OF THE SEWER MAIN. INSPECTION BY SEWER UTILITY REQUIRED PRIOR TO BACKFILL.
7. A LETTER "S" SHALL BE STAMPED OR CHISELED INTO FACE OF CURB AT THE LOCATION OF THE LATERAL CROSSING THE CURB LINE, NOT LESS THAN 1-1/2" HIGH AND 3/16" DEEP.
8. MINIMUM COVERAGE OVER SEWER LATERAL IS 18-INCHES BELOW 6,000 FEET IN ELEVATION AND 24-INCHES ABOVE 6,000 FEET IN ELEVATION MEASURED FROM FINISHED GRADE TO TOP OF LATERAL. SEE ALSO NOTE 2.
9. TRACER WIRE REQUIRED ON DOUGLAS COUNTY, KINGSBURY GENERAL IMPROVEMENT DISTRICT, AND TAHOE DOUGLAS SEWER IMPROVEMENT DISTRICT LATERALS. NOT REQUIRED BY OTHER SEWER PROVIDERS.

NO.	REVISION	DATE	STANDARD DETAIL FOR PUBLIC WORKS CONSTRUCTION	SECTION: DOUGLAS COUNTY
			SEWER LATERAL	DATE: JULY 2017
				DWG: C06

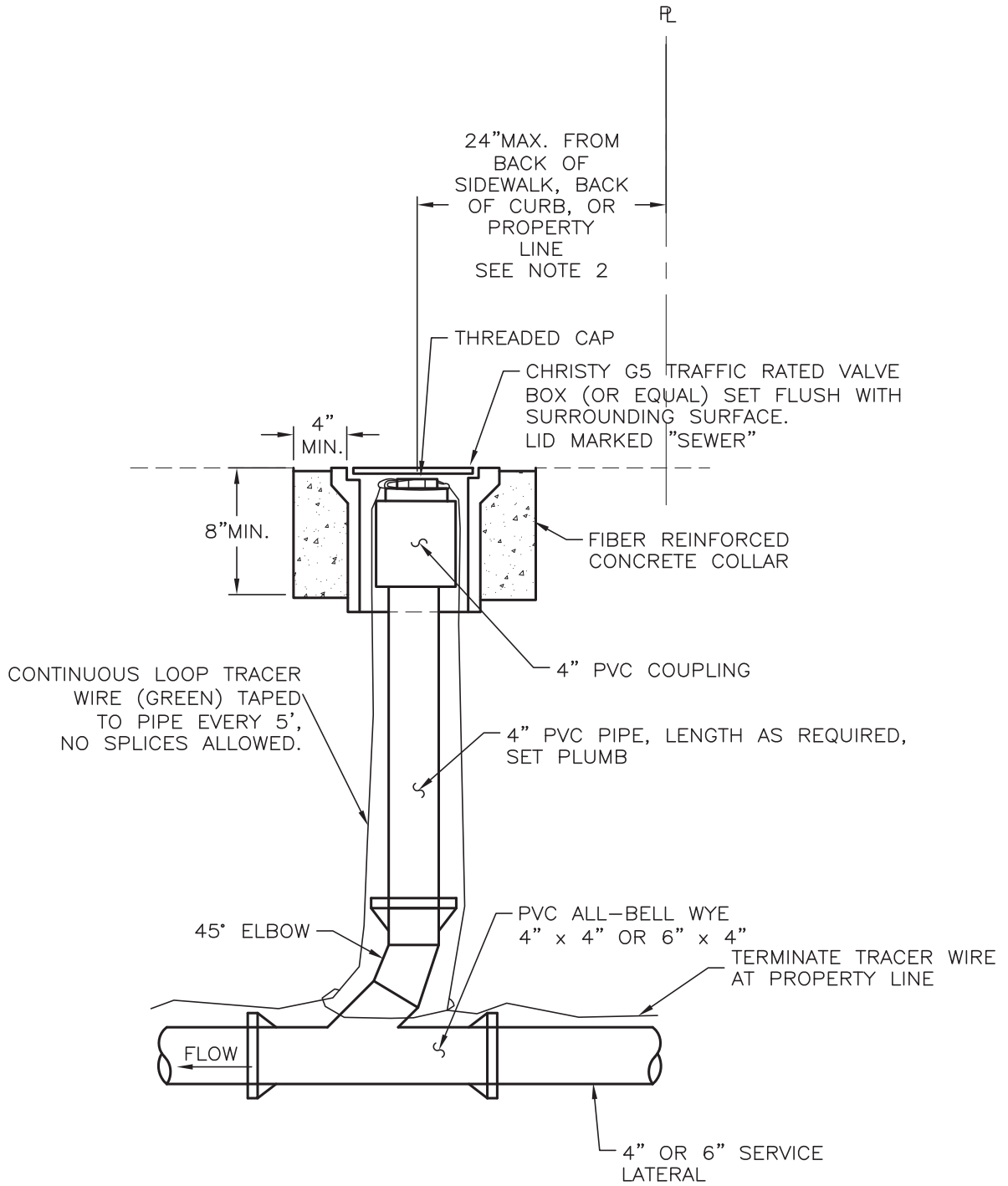

NOTE: ALL JOINTS AND CONNECTIONS SHALL BE WATERTIGHT.

NOTES:

1. CLEANOUTS TO BE PLACED AT EVERY ANGLE GREATER THAN, OR EQUAL TO 45°, EVERY 150' OF LATERAL, AND WITHIN 5' OF BUILDING AND IN CONFORMANCE WITH THE CURRENT EDITION OF THE UNIFORM BUILDING CODE. CLEANOUTS INSTALLED AT ANGLES SHALL BE LOCATED ON THE UPSTREAM SIDE OF THE ANGLE. CLEANOUTS SHALL BE LOCATED AS CLOSE AS PRACTICAL TO THE ANGLE.
2. CLEANOUT SHALL NOT BE LOCATED WITHIN A ROADSIDE DITCH UNDER ANY CIRCUMSTANCES.

NO.	REVISION	DATE	STANDARD DETAIL FOR PUBLIC WORKS CONSTRUCTION	SECTION: DOUGLAS COUNTY
			SEWER LATERAL CLEANOUT	DATE: JULY 2017
				DWG: C07

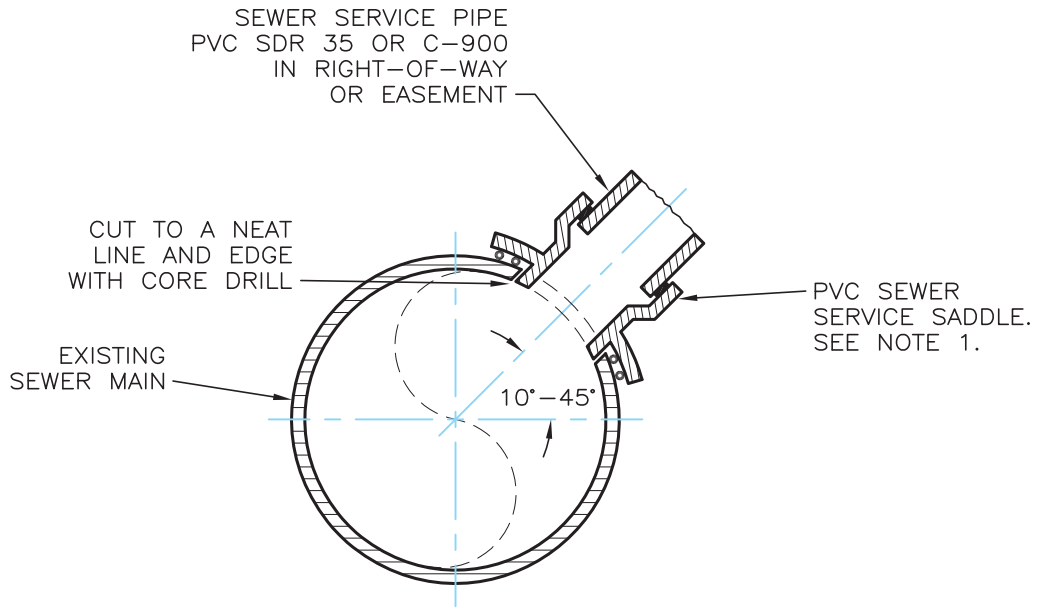

FRONT VIEW

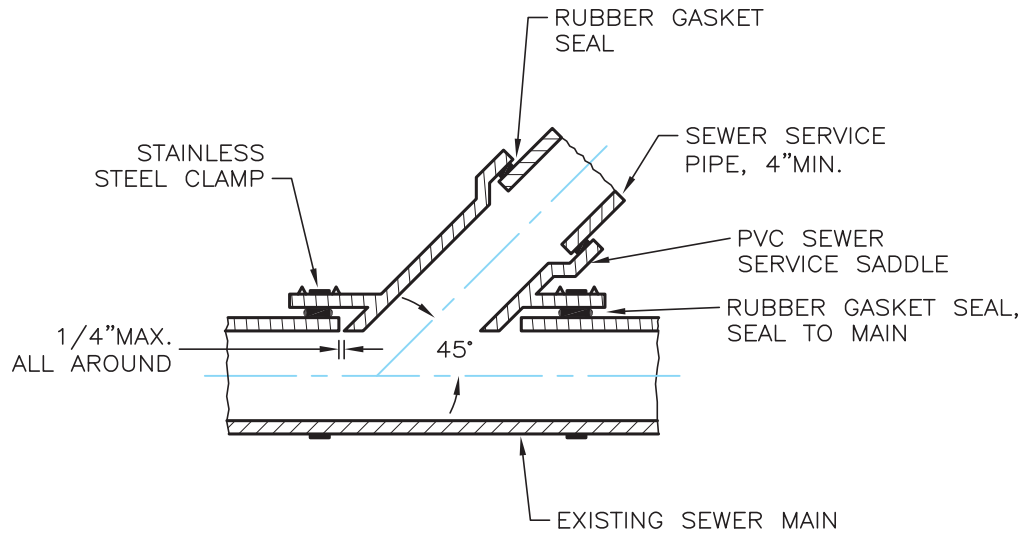

SIDE VIEW

NOTES:

1. TYPE OF SERVICE SADDLE PER SEWER UTILITY APPROVAL.
2. THIS DETAIL IS ONLY APPLICABLE WHEN CONNECTING TO AN EXISTING MAIN.

NO.	REVISION	DATE	STANDARD DETAIL FOR PUBLIC WORKS CONSTRUCTION	SECTION: DOUGLAS COUNTY
			SEWER SERVICE SADDLE	DATE: JULY 2017
				DWG: C08

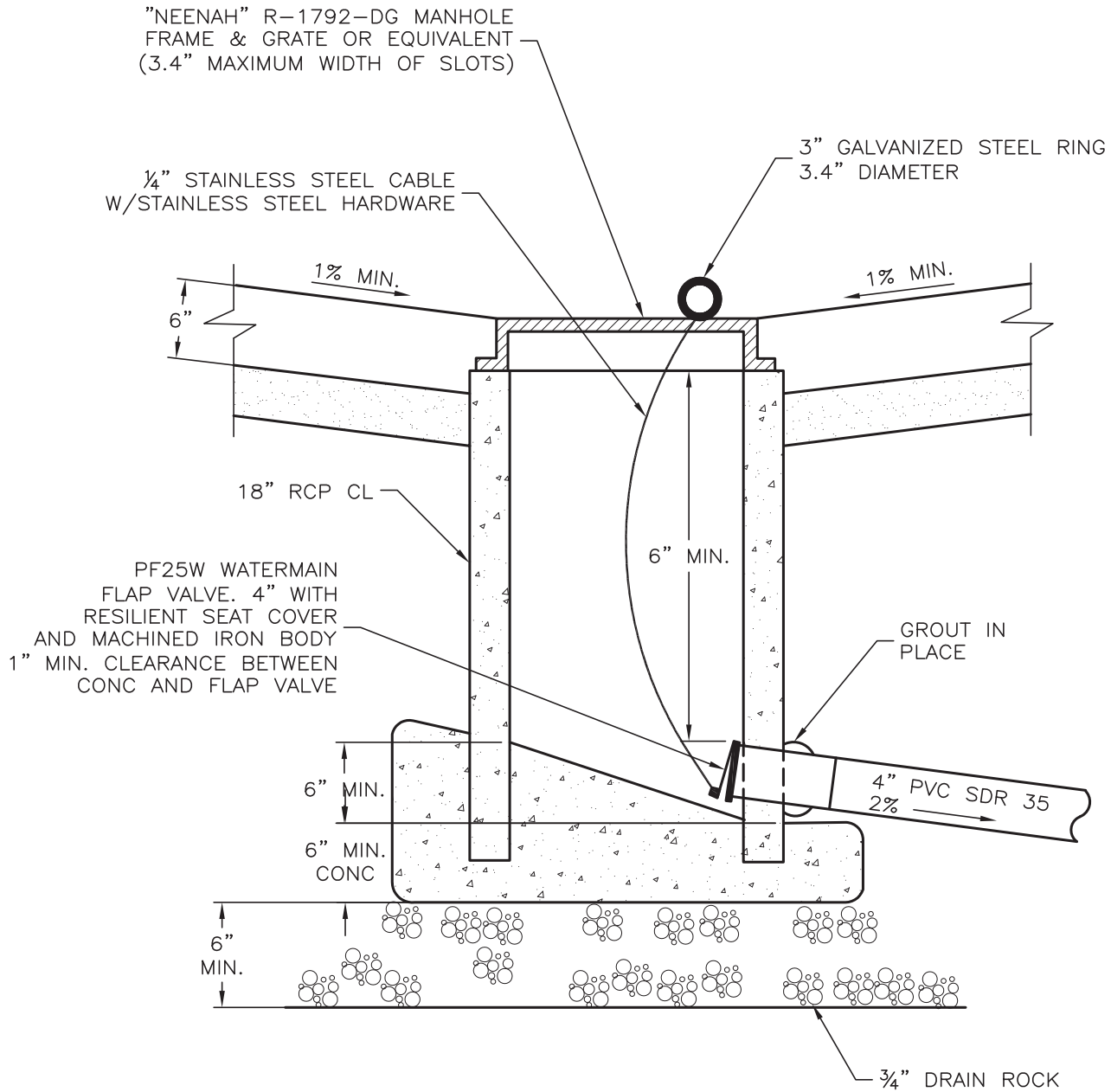

NOTES:

1. TRENCH DRAIN SHALL BE CONNECTED TO A GREASE INTERCEPTOR.
2. SIZE OF TRASH ENCLOSURE TO BE DETERMINED BY REFUSE UTILITY.
3. SCARIFY AND RECOMPACT TO 90% RELATIVE COMPACTION.
4. 4,000 PSI CONCRETE 4% TO 6% AIR ENTRAINMENT.

NO.	REVISION	DATE	STANDARD DETAIL FOR PUBLIC WORKS CONSTRUCTION	SECTION: DOUGLAS COUNTY
			DUMPSTER PAD DRAIN SYSTEM	DATE: JULY 2017
				DWG: C09

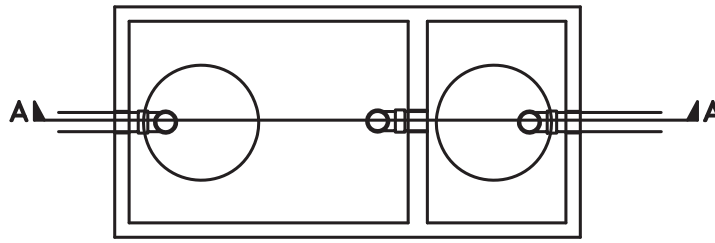

PLAN VIEW
(COVERS & RISERS REMOVED)

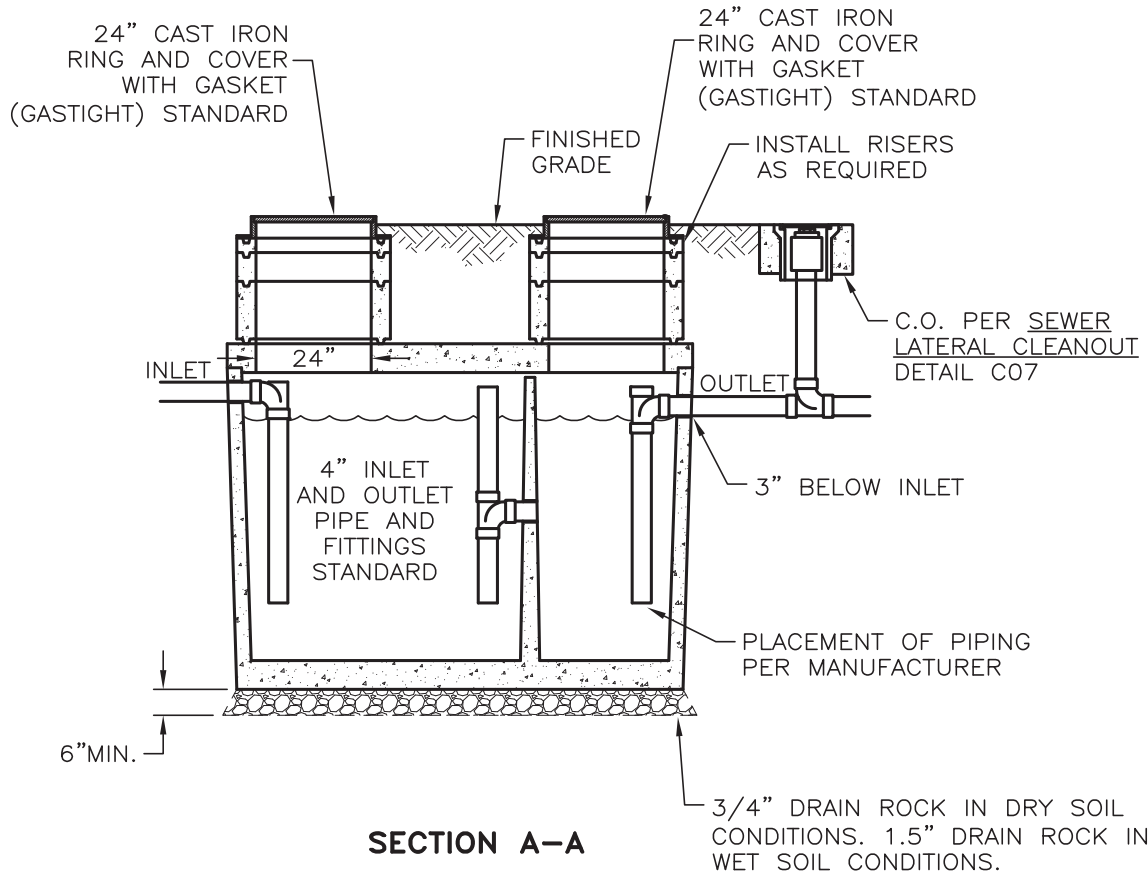

SECTION A-A

NOTES:

1. INSTALL JENSEN PRECAST GREASE INTERCEPTORS (MODELS JP320EE-G THROUGH JP2000EE-G AND JZ2500EE-G THROUGH JZ5000EE-G) WITH H-20 TRAFFIC FROM 1' TO 6' SOIL COVER, OR APPROVED EQUAL.
2. REFER TO SEWER UTILITY REQUIREMENTS FOR MINIMUM SIZING.
3. ALL FITTINGS SHALL BE SOLVENT AND WELDED.
4. AVOID PLACING IN PARKING SPACES AND LANDSCAPE AREAS. IF NECESSARY, PROVIDE DESIGN BY ENGINEER. MOUND IN PARKING/SIDEWALK AREAS TO CHANNEL DRAINAGE AWAY FROM INTERCEPTOR. LIDS SHALL BE 1" ABOVE FINISHED GRADE IN ASPHALT CONCRETE/CONCRETE AREAS AND 3" ABOVE FINISHED GRADE IN LANDSCAPE AREAS.
5. DUMPSTER DRAINS SHALL BE ROUTED THROUGH GREASE INTERCEPTORS.
6. CONCRETE COLLAR AROUND LIDS TO INTERCEPTOR.

NO.	REVISION	DATE	STANDARD DETAIL FOR PUBLIC WORKS CONSTRUCTION	SECTION: DOUGLAS COUNTY
			GREASE INTERCEPTOR	DATE: JULY 2017
				DWG: C10



Appendix D

Storm Drainage Details

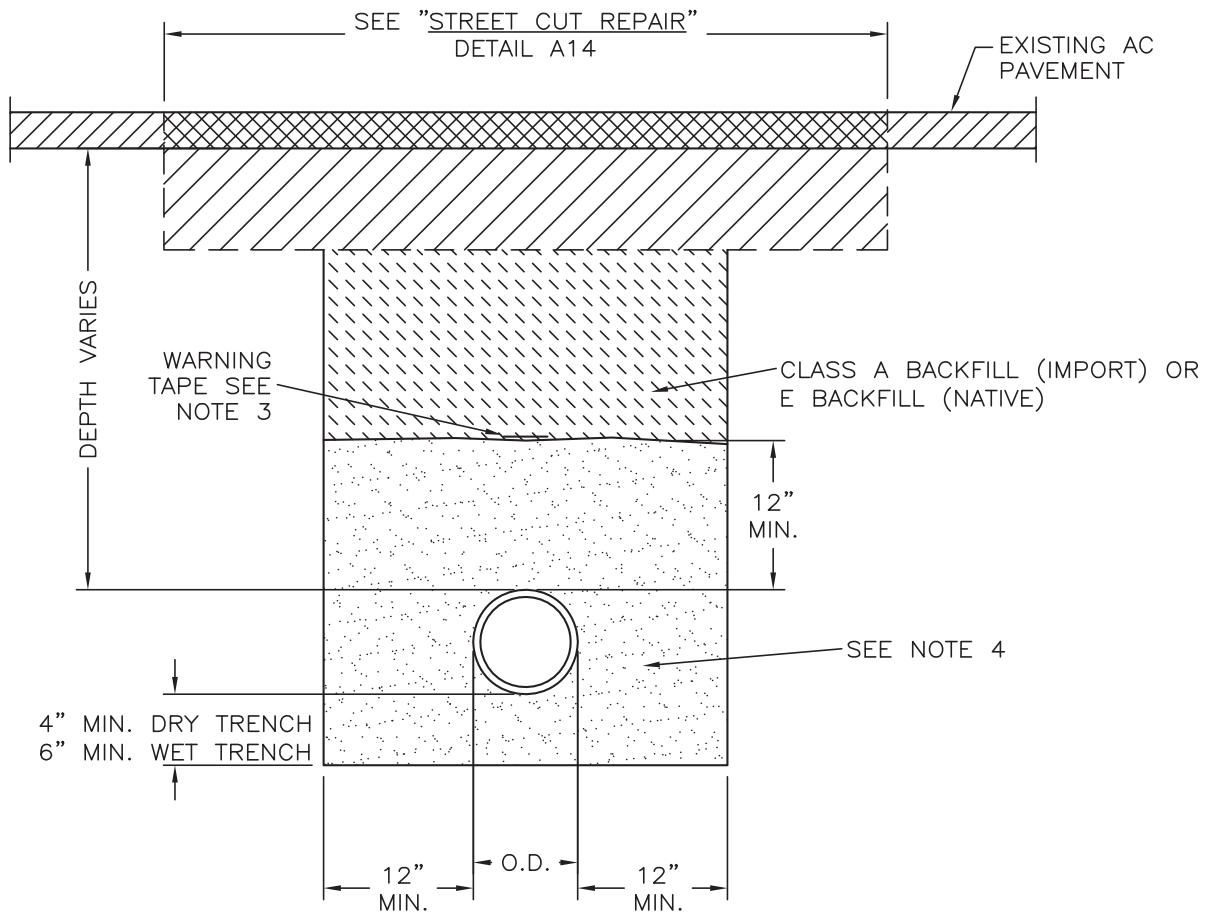

THE FOLLOWING GRADED BEDDING MATERIAL MAY BE USED IN WET TRENCHES:

U.S. STANDARD SIEVE SIZE

PERCENT BY WEIGHT PASSING

1.5"
1"
3/4"
3/8"
#4
#200

100%
50-90%
30-70%
10-40%
5-25%
0-10%

CLASS A BACKFILL PER ORANGE BOOK 200.03.02 USED AS BEDDING MATERIAL MUST BE USED IN DRY TRENCHES ONLY, SEE NOTE 4.

SEE NOTES ON PAGE 2

PAGE 1 OF 2

NO.	REVISION	DATE	STANDARD DETAIL FOR PUBLIC WORKS CONSTRUCTION	SECTION: DOUGLAS COUNTY
			TYPICAL STORM DRAIN TRENCH	DATE: JULY 2017
				DWG: D01

NOTES:

1. ALL REQUIREMENTS OF THE STORM DRAIN UTILITY ORDINANCE MUST BE MET.
2. CLASS A AND CLASS E BACKFILL AND BEDDING MATERIAL SHALL CONFORM TO SECTION 200 OF THE STANDARD SPECIFICATIONS FOR PUBLIC WORKS CONSTRUCTION. BEDDING AND BACKFILL SHALL BE MECHANICALLY COMPACTED IN CONFORMANCE WITH SECTION 305.10 OF THE STANDARD SPECIFICATIONS FOR PUBLIC WORKS CONSTRUCTION.
3. PLACE WARNING TAPE 1-FOOT ABOVE STORM DRAIN PIPE. WARNING TAPE SHALL READ "CAUTION STORM DRAIN MAIN".
4. CLASS A BACKFILL AS BEDDING MATERIAL PER ORANGE BOOK 200.03.02. COMPACT OR CONSOLIDATE TO PROVIDE PROPER SUPPORT OF PIPE.
5. UTILIZE WATER STOP DETAIL D02 FOR WET TRENCHES.

NO.	REVISION	DATE	STANDARD DETAIL FOR PUBLIC WORKS CONSTRUCTION	SECTION: DOUGLAS COUNTY
			TYPICAL STORM DRAIN TRENCH	DATE: JULY 2017
				DWG: D01

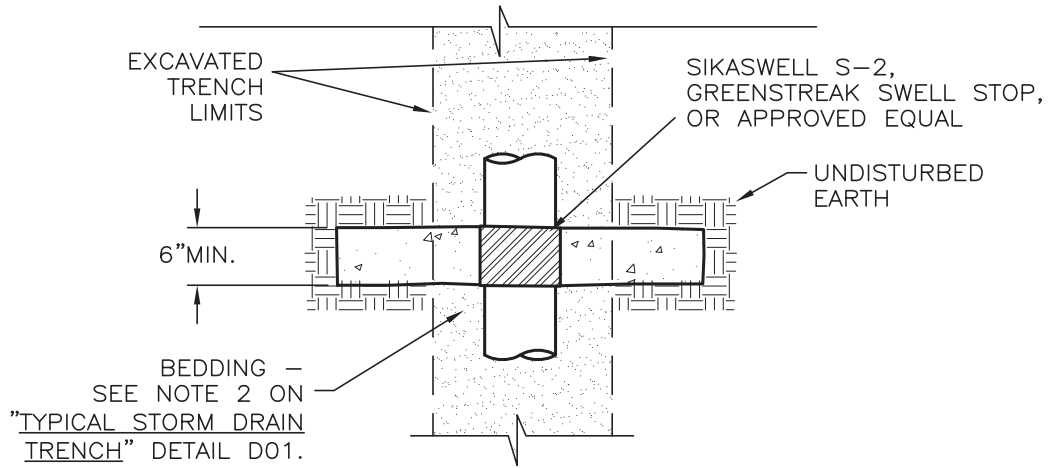

PLAN

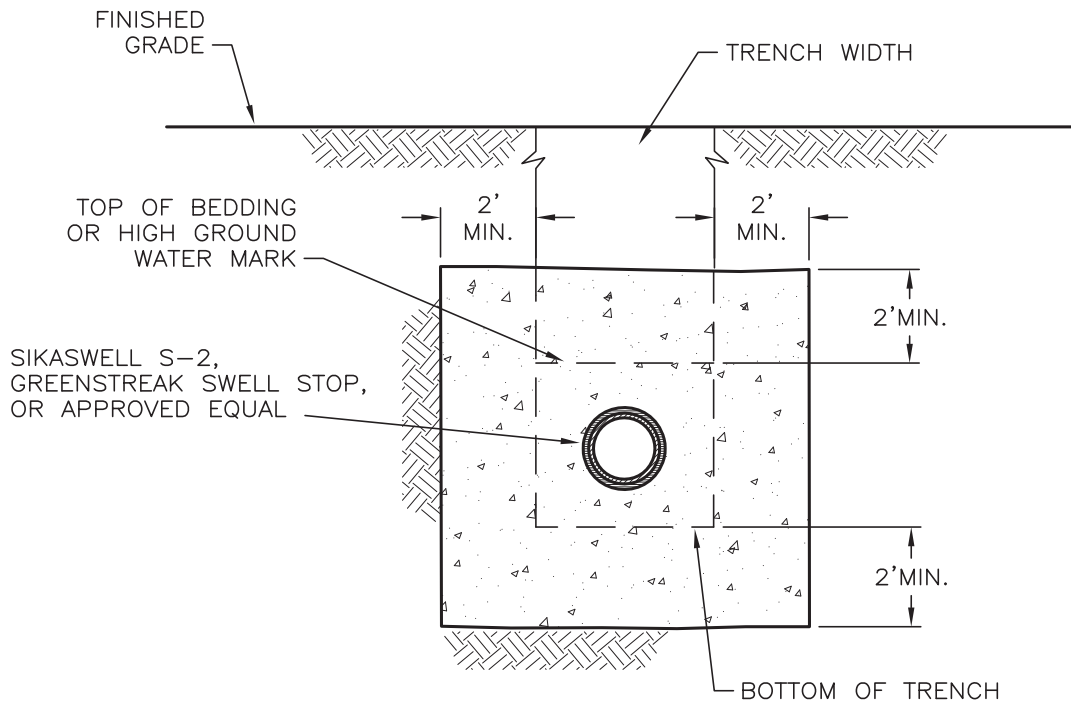

SECTION

NOTES:

1. WATER STOPS SHALL BE CONSTRUCTED AT 200-FOOT MAXIMUM SPACING IN GROUND WATER CONDITIONS AND WHERE WET TRENCH BEDDING IS USED, AS DIRECTED BY SEWER UTILITY.
2. WRAP PIPE WITH SIKASWELL S-2, OR, GREENSTREAK SWELL STOP, OR EQUIVALENT WHERE PIPE IS EXPOSED TO CONCRETE PRIOR TO POURING.
3. USE LIGHT CONCRETE TYPE A SLURRY BACKFILL PER ORANGE BOOK 337.08.01-1. IF CEMENT BOARD IS USED FOR CONCRETE FORMS, IT MAY BE LEFT IN PLACE.

NO.	REVISION	DATE	STANDARD DETAIL FOR PUBLIC WORKS CONSTRUCTION	SECTION: DOUGLAS COUNTY
			WATER STOP	DATE: JULY 2017
				DWG: D02

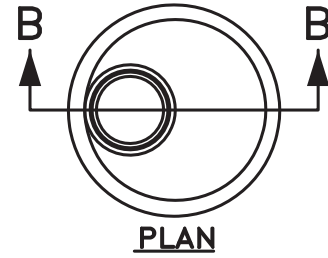
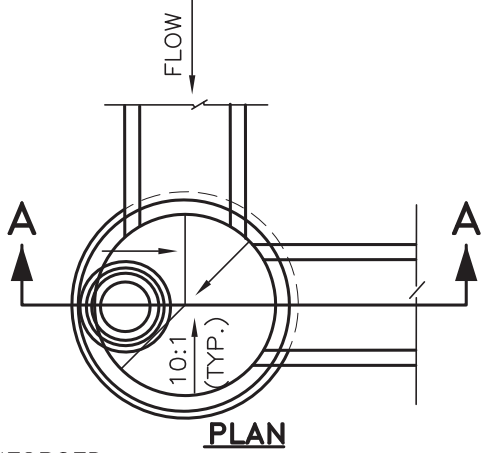

FIBER REINFORCED CONCRETE COLLAR FULL DEPTH

MANHOLE LID (SEE TEMPORARY COVER DETAIL A13)

STREET ELEVATION*

3" OR 6" ADJUSTING GRADE RING, MAX HEIGHT 12", AS REQUIRED TO MEET STREET ELEVATION

36"
24" DIA.

48" TO 24" ECCENTRIC RCP TAPERED SECTION

48" RCP SECTIONS 1', 2', 3', OR 4' LENGTHS AS REQUIRED

"RAM-NEK" MASTIC GASKET OR EQUAL (TYP.)

KOR-N-SEAL OR A-LOK BOOT OR APPROVED EQUIVALENT AT ALL PENETRATIONS

SEE NOTE 3

SHAPE FLOWLINE TO OUTLET

12"

ANTI-FLOAT BASE FOR GROUNDWATER CONDITIONS, OPTIONAL PER DESIGN ENGINEER

SECTION A-A

TYPE 1 MANHOLE ECCENTRIC

6" AB COMPACT TO 95% RELATIVE COMPACTION

D = 4'-0" FOR 15" TO 24" STORM DRAIN PIPE

SEE MANHOLE NOTES ON D05

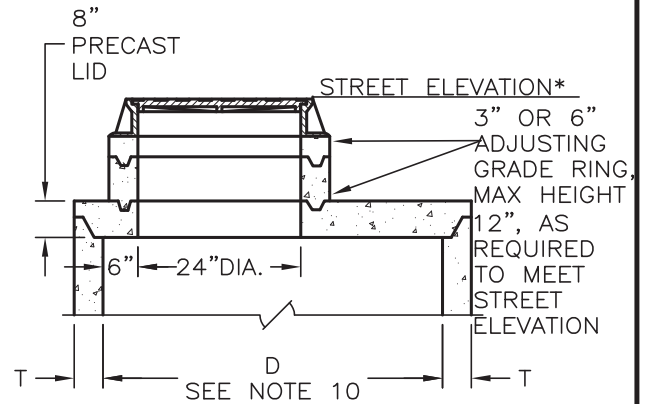

SECTION B-B

FOR USE IN MINIMUM COVER SITUATION WHERE TAPERED SECTION WILL NOT FIT. THIS APPLICABLE FOR BOTH TYPE 1 AND TYPE 2 MANHOLES.

* STREET SECTION IS 1/4" ABOVE CONCRETE COLLAR AND C.I. FRAME.

NO.	REVISION	DATE	STANDARD DETAIL FOR PUBLIC WORKS CONSTRUCTION	SECTION: DOUGLAS COUNTY
			MANHOLES FOR 15" - 24"	DATE: JULY 2017
				DWG: D03

**TYPE 2
MANHOLE
ECCENTRIC**

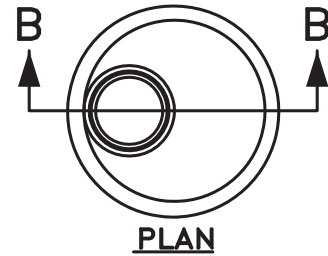
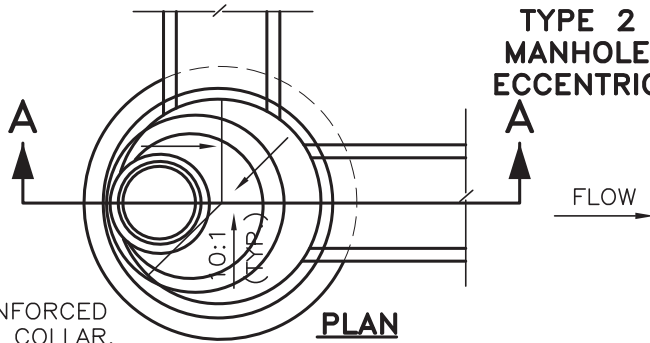

PLAN

FIBER REINFORCED
CONCRETE COLLAR,
FROM 2" BELOW TOP
OF CONE

PLAN

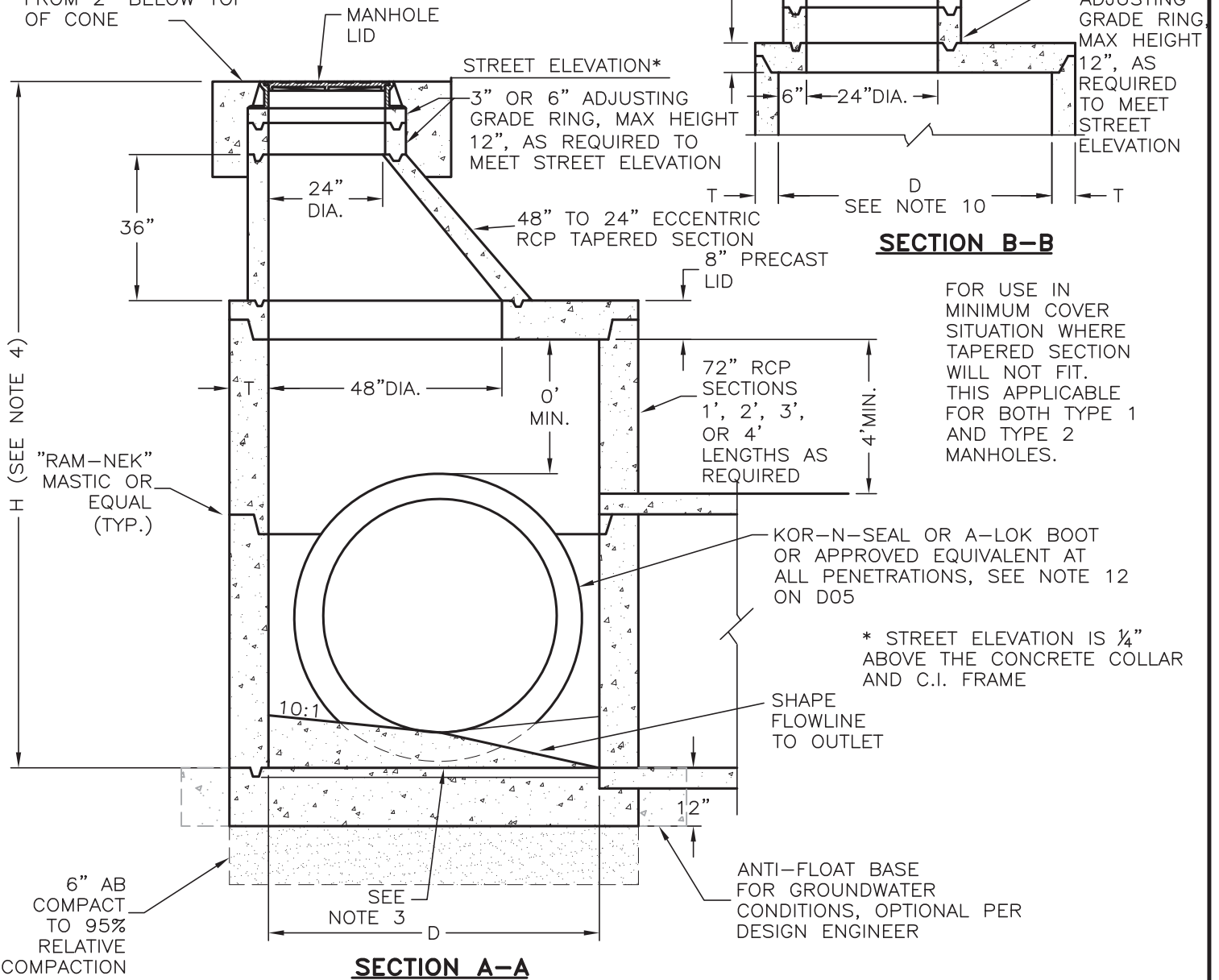

SECTION B-B

FOR USE IN
MINIMUM COVER
SITUATION WHERE
TAPERED SECTION
WILL NOT FIT.
THIS APPLICABLE
FOR BOTH TYPE 1
AND TYPE 2
MANHOLES.

* STREET ELEVATION IS 1/4" ABOVE THE CONCRETE COLLAR AND C.I. FRAME

SHAPE FLOWLINE TO OUTLET

ANTI-FLOAT BASE FOR GROUNDWATER CONDITIONS, OPTIONAL PER DESIGN ENGINEER

SECTION A-A

D = 6'-0" FOR 30" TO 48" STORM DRAIN PIPE

SEE MANHOLE NOTES ON D05

NO.	REVISION	DATE	STANDARD DETAIL FOR PUBLIC WORKS CONSTRUCTION	SECTION: DOUGLAS COUNTY
			MANHOLES FOR 30" - 48"	DATE: JULY 2017
				DWG: D04

MANHOLE NOTES:

1. FOR CAST IN PLACE CONCRETE BASE ALL REINFORCING STEEL TO BE NO. 4 BARS AT 18 INCH CENTERS TIGHTLY WOUND AT ALL INTERSECTIONS AND EMBEDDED IN CONCRETE AT LEAST 2 INCHES AND BAR ENDS MUST CLEAR CONCRETE SURFACES BY 1-1/2 INCHES.
2. ALL CONCRETE SHALL CONFORM TO THE REQUIREMENTS OF SECTION 202 OF THE STANDARD SPECIFICATIONS FOR PUBLIC WORKS CONSTRUCTION FOR CONCRETE EXPOSED TO FREEZE-THAW ENVIRONMENTS.
3. MANHOLE WITH MORE THAN ONE PIPE-INFLOW, PIPE INVERT ELEVATIONS SHALL BE \geq 0.1 FOOT ABOVE OUTFLOW PIPE ELEVATION FOR STRAIGHT FLOW THROUGH, OR 0.2 FOOT FOR 90° BEND FLOW THROUGH.
4. FOR VALUES OF "H" SEE PLANS. "H" IS THE DIFFERENCE IN ELEVATION BETWEEN THE OUTFLOW PIPE INVERT ELEVATION AND THE TOP OF MANHOLE ELEVATION AT STREET GRADE.
5. DO NOT PLACE PIPES IN TAPERED SECTION.
6. MANHOLE COVER SHALL BEAR "STORM DRAIN" ON LID.
7. IF PIPES OF DIFFERENT DIAMETERS ENTER OR EXIT THE SAME MANHOLE, THE CROWNS OF THE PIPE SHALL BE AT THE SAME ELEVATION. THE LARGEST PIPE IN THE MANHOLE SHALL GOVERN THE DIAMETER OF THE MANHOLE.
8. LADTECH HDPE ADJUSTMENT RINGS FOR MANHOLES MAY BE USED PER MANUFACTURER'S RECOMMENDATIONS. WOOD SHIMS MAY NOT BE USED IN CONJUNCTION WITH LADTECH RINGS. OTHER ADJUSTING RINGS MAY BE CONSIDERED FOR APPROVAL BY ENTITY THAT WILL MAINTAIN THE ROADWAY.
9. T = THICKNESS PIPE WALL.
10. D = DIAMETER.
11. SUBGRADE SHALL BE COMPACTED IN CONFORMANCE WITH SECTION 302 OF THE STANDARD SPECIFICATIONS FOR PUBLIC WORKS CONSTRUCTION.
12. FOR MANHOLE CONNECTIONS WITH PIPE DIAMETER GREATER THAN 36-INCHES, THE BOOT SHALL NOT BE REQUIRED. ALL PIPE CONNECTIONS GREATER THAN 36-INCH IN DIAMETER SHALL BE GROUTED IN INTERIOR & EXTERIOR OF THE MANHOLE, GROUT SHALL CONFORM TO THE STANDARD SPECIFICATIONS FOR PUBLIC WORKS CONSTRUCTION SECTION 200.04.

NO.	REVISION	DATE	STANDARD DETAIL FOR PUBLIC WORKS CONSTRUCTION	SECTION: DOUGLAS COUNTY
			STORM DRAIN MANHOLE NOTES	DATE: JULY 2017
				DWG: D05

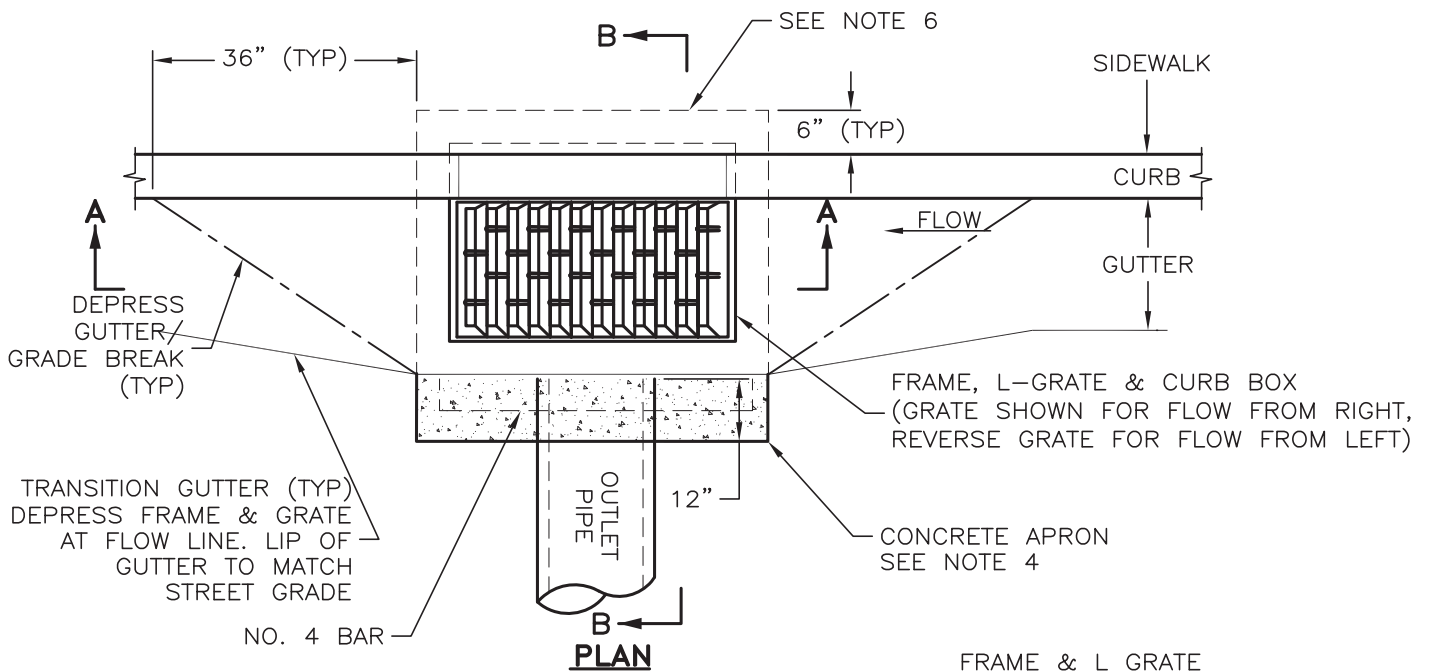

PLAN

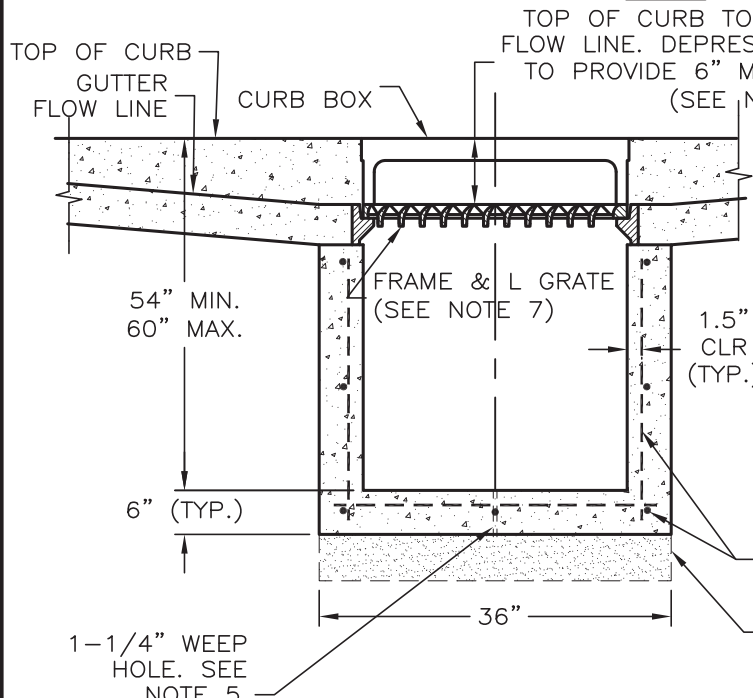

SECTION A-A

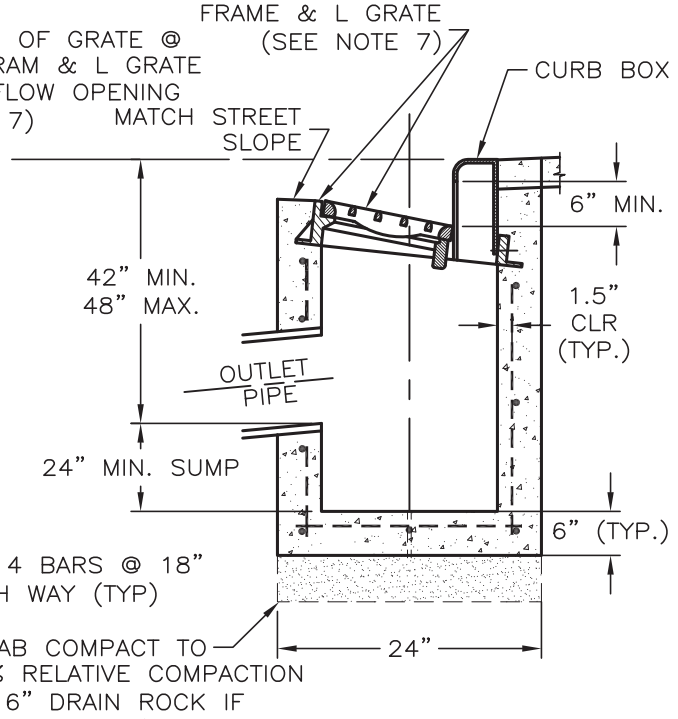

SECTION B-B

NOTES:

1. SUBGRADE SHALL BE COMPACTED IN CONFORMANCE WITH SECTION 302 OF THE STANDARD SPECIFICATIONS FOR PUBLIC WORKS CONSTRUCTION.
2. A MINIMUM OF 6-INCHES OF GRADED BEDDING MATERIAL AS DESCRIBED IN "TYPICAL STORM DRAIN TRENCH" DETAIL D01 SHALL BE CONSTRUCTED.
3. CONCRETE BOX SHALL BE DESIGNED FOR H-20 TRAFFIC LOAD.
4. IF FRAME AND GRATE EXTEND BEYOND LIP OF GUTTER, PROVIDE 8-INCH THICK CONCRETE APRON.
5. IF SOILS AND GROUNDWATER DEPTH WILL ALLOW, DRILL 1-1/4" WEEP HOLE AT BOTTOM OF INLET TO ALLOW WATER TO INFILTRATE INTO SOIL.
6. IF NO SIDEWALK IS PRESENT, POUR 6-INCH CONCRETE CURB STRUCTURE BEHIND GRATE AND TIE BEAM INTO BOX.
7. TILT FRAME & GRATE AS REQUIRED TO ATTAIN 6-INCH MINIMUM FLOW OPENING AND INSTALL DURABLE SHIMS BETWEEN THE CURB BOX AND FRAME AS REQUIRED TO MATCH CURB BOX TO TOP OF CURB AND FACE OF CURB (SEE SECTION B-B).

NO.	REVISION	DATE	STANDARD DETAIL FOR PUBLIC WORKS CONSTRUCTION	SECTION: DOUGLAS COUNTY
			TYPE 4R CURB INLET AND GRATE	DATE: JULY 2017
				DWG: D06

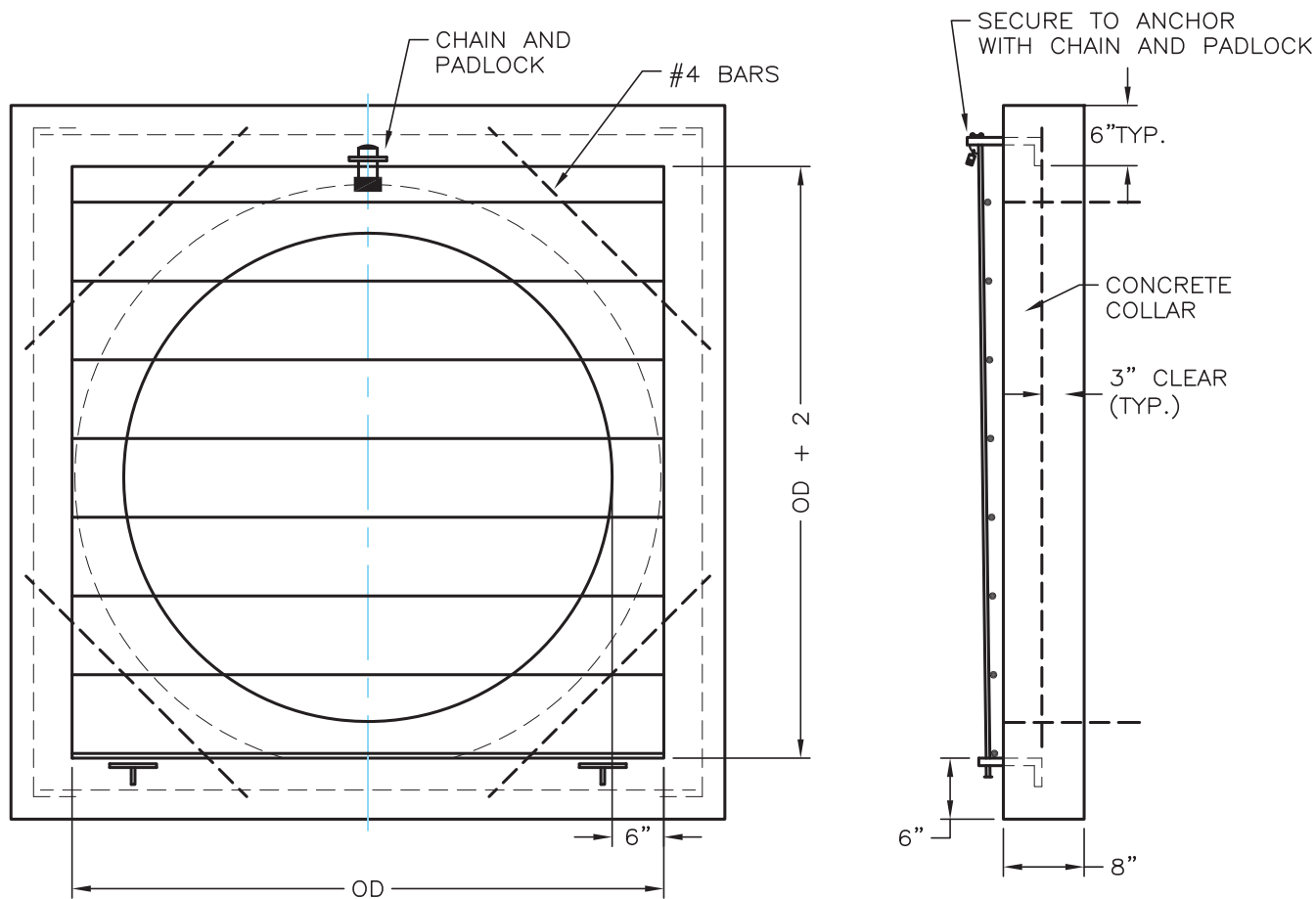

PIPE SIZE	BAR SIZE
21"	4
24"	4
27"	5
30"	5
33"	6
36"	6
42"	7
48"	7
54"	7
60"	8
66"	8
72"	8
84"	8

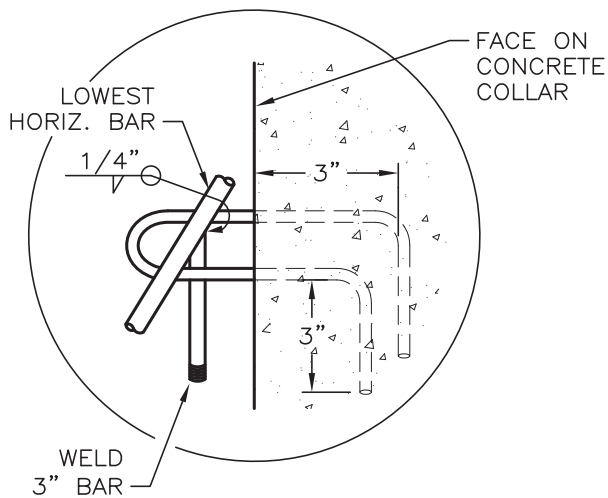

NOTES:

1. RACK TO BE WELDED REINFORCING STEEL OR ROUND BARS OF EQUAL DIAMETER WITH HORIZONTAL BARS BEING 8" CENTER TO CENTER.
2. PORTLAND CEMENT CONCRETE SHALL CONFORM TO THE REQUIREMENTS OF SECTION 202 OF THE STANDARD SPECIFICATIONS FOR PUBLIC WORKS CONSTRUCTION FOR CONCRETE EXPOSED TO FREEZE-THAW ENVIRONMENTS.

NO.	REVISION	DATE	STANDARD DETAIL FOR PUBLIC WORKS CONSTRUCTION	SECTION: DOUGLAS COUNTY
			ACCESS CONTROL RACK	DATE: JULY 2017
				DWG: D07

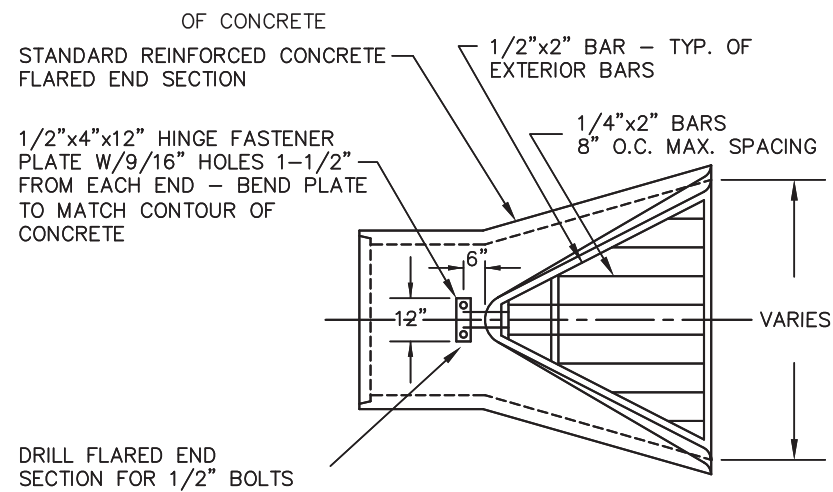
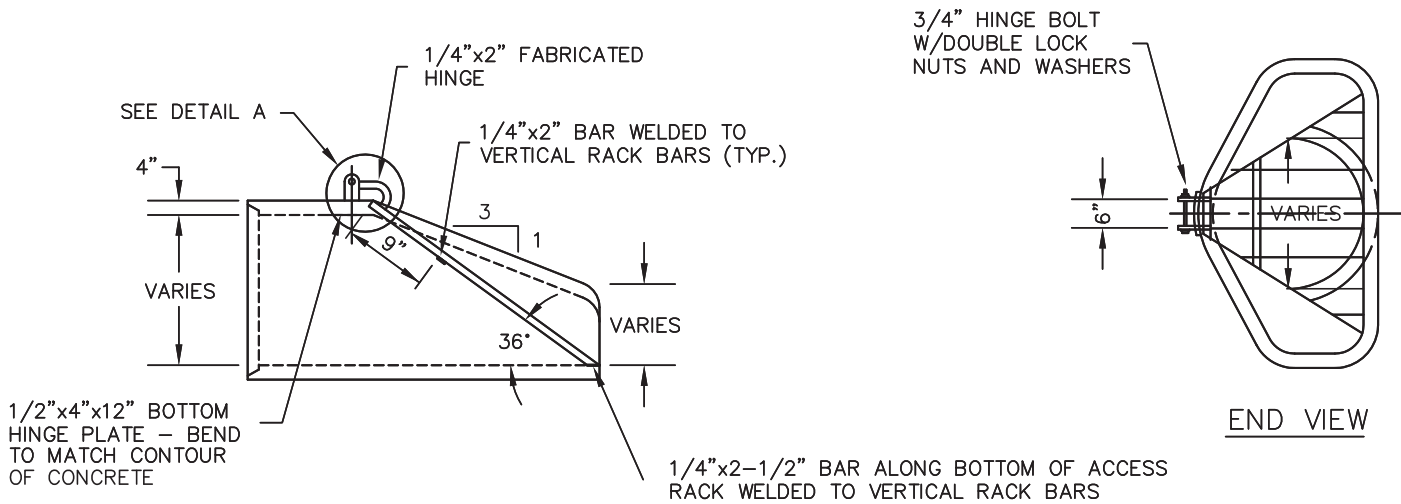

NOTE: ALL STEEL ASTM A-36.

ALL WELDS TO BE 1/4" FILLET WELDS ALL AROUND.

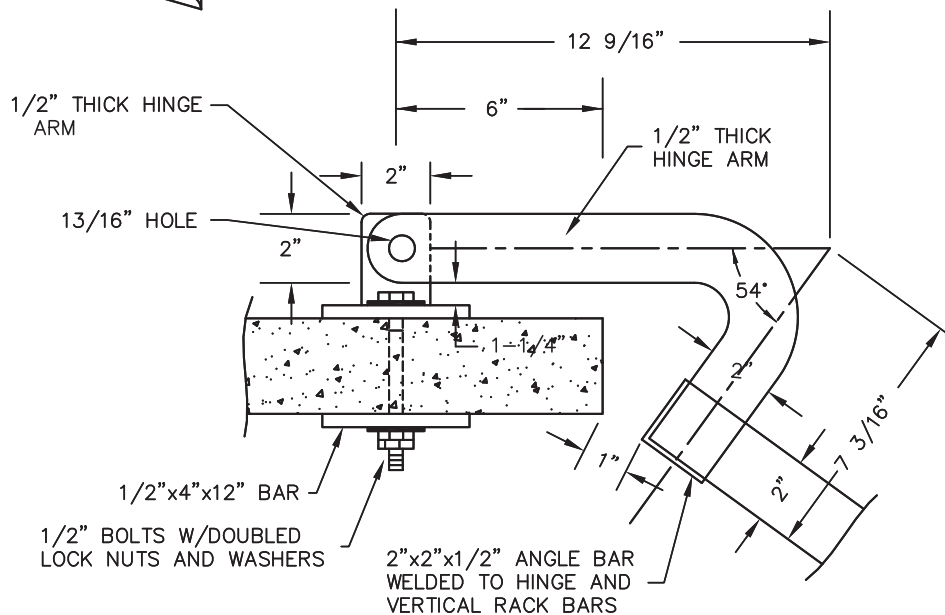

DETAIL A

NO.	REVISION	DATE	STANDARD DETAIL FOR PUBLIC WORKS CONSTRUCTION	SECTION: DOUGLAS COUNTY
			<h1>TRASH RACK</h1>	DATE: JULY 2017
				DWG: D08



Appendix E

Erosion Control Details (Reserved)



Appendix F

Acronyms, Abbreviations, and Definitions

APPENDIX F ACRONYMS, ABBREVIATIONS, AND DEFINITIONS

Words and phrases are defined as set out in this division unless it is apparent that from the context they have a different meaning. All words used in the present tense include the future; all words in the singular include the plural; the word “**building**” includes the word “**structure**,” the word “**shall**” or “**must**” is mandatory, the word “**may**” is permissive, the word “**person**” includes “**firm**,” “**association**,” “**corporation**,” “**partnership**” and “**natural person**”; the word “**used**” includes the words “**arranged**,” “**designed**” or “**intended to be used**”; the word “**construct**” includes the words “**erect**,” “**reconstruct**,” “**alter**,” “**move in**” and “**move upon**”; masculine and feminine terms such as “**he**” and “**she**” are used interchangeably; words not defined herein shall have meanings as set forth in “*Webster’s Ninth New College Dictionary*.”

If the definitions stated herein at any time conflict with the definitions provided in other divisions of this documents, the more restrictive interpretation shall apply.

Acronyms and Abbreviations

The following acronyms and abbreviations are used within the contents of this manual:

1.	AASHTO	American Association of State Highway and Transportation Officials
2.	ADT	Average Daily Traffic
3.	ANSI	American National Standards Institute
4.	APWA	American Public Works Association
5.	ASCE	American Society of Civil Engineers
6.	ASTM	American Society for Testing and Materials
7.	AWS	American Welding Society
8.	AWWA	American Water Works Association
9.	BC	Begin Curve
10.	BCC, BOC	The Douglas County Board of County Commissioners
11.	BVC	Begin Vertical Curve
12.	CAP	Corrugated Aluminum Pipe
13.	CAPA	Corrugated Aluminum Pipe Arch
14.	CEC	Consulting Engineers Council
15.	CMP	Corrugated Metal Pipe
16.	CMPA	Corrugated Metal Pipe Arch
17.	CSP	Corrugated Steel Pipe
18.	CSPA	Corrugated Steel Pipe Arch
19.	EC	End Curve
20.	EGL	Energy Grade Line
21.	EPA	Environmental Protection Agency
22.	EVC	End Vertical Curve
23.	FEMA	Federal Emergency Management Agency
24.	GPM, gpm	Gallons Per Minute
25.	HDS	Hydraulic Design Series
26.	HEC	Hydraulic Engineering Circular
27.	HERCP	Horizontal Elliptical Reinforced Concrete Pipe
28.	HGL	Hydraulic Grade Line

29.	IBC	International Building Code
30.	IRC	International Residential Code
31.	ITE	Institute of Transportation Engineers
32.	LOS	Level of Service
33.	MGD, mgd	Million Gallons Per Day
34.	MUTCD	Manual of Uniform Traffic Control Devices
35.	NDOT	Nevada Department of Transportation
36.	NFIP	National Flood Insurance Program
37.	NFS	National Sanitation Foundation
38.	NEC	National Electric Code
39.	NEMA	National Electrical Manufacturers Association
40.	NOAA	National Oceanic and Atmospheric Administration
41.	NAC	Nevada Administrative Code
42.	NRCS	Natural Resource Conservation Service
43.	NRS	Nevada Revised Statutes
44.	NWS	National Weather Service
45.	PE	Professional Engineer Licensed by the State of Nevada
46.	PMF	Probable Maximum Flood
47.	RCBC	Reinforced Concrete Boxed Culvert
48.	RCP	Reinforced Concrete Pipe
49.	ROW	Right-of-Way
50.	RTC	Regional Transportation Commission of Douglas County
51.	SPP	Structural Plate Pipe
52.	SPPA	Structural Plate Pipe Arch
53.	TRB	Transportation Research Board
54.	UL	Underwriters Laboratories
55.	UMC	Uniform Mechanical Code
56.	UPC	Uniform Plumbing Code
57.	USACE, COE	United State Army Corps of Engineers
58.	USBR, BUREC	Unites States Bureau of Reclamation
59.	USGS	United States Geological Survey
60.	WEF	Water Environment Federation

Definitions

1. **Acre, gross** - A gross acre consists of 43,560 square feet of land, and includes any public streets and alleys or other rights-of-way or easements.
2. **Acre, net** - A net acre consists of 43,560 square feet of land, exclusive of any public streets and alleys or other rights-of-way, but inclusive of public utility, drainage, or irrigation maintenance easements. Unless otherwise stated “acre” means “net acre” wherever used in this manual.
3. **Air Gap** - A physical separation between a point of free-flowing discharge from a pipe that supplies liquid to an open or non pressurized vessel and the overflow rim of that vessel which is:
 - a. at least twice the effective diameter of that pipe or, if the pipe is affected by side walls, at least three times the effective diameter of that pipe; and
 - b. in no case less than 1 inch.
4. **Alley** - A public or private way, at the rear or side of property, permanently reserved as an ancillary means of vehicular or pedestrian access to abutting property.

5. **ANSI** - The American National Standards Institute, located at 11 W. 42nd St., 13th Floor, New York, New York, (212) 642-4900.
6. **Applicant** - The person, firm, association, corporation or governmental agency applying for service provided by County, utility, or other provider.
7. **Approved Backflow Testing Laboratory** - The Foundation for Cross-Connection Control and Hydraulic Research of the University of Southern California; or any person or entity who the health authority determines:
 - a. is competent and possesses the necessary facilities to investigate and evaluate assemblies for the prevention of;
 - b. Adheres to the procedures for testing and certification set forth in the American Water Works Association Standards; and
 - c. Is independent of any manufacturers of assemblies for the prevention of backflow.
8. **ASME** - The American Society of Mechanical Engineers, located at United Engineering Center, 345 E. 47th St., New York, NY 10017, (212) 705-7722.
9. **Average Daily Flow** - The average daily sewage flow for a single family detached residence is 250 gallons per day. This figure includes inflow and infiltration.
10. **Average Day Demand** - The average daily demand for water over a yearly period, as determined by historical data.
11. **Average Month** - Thirty (30) days.
12. **Average Quarter** - Ninety (90) days.
13. **AWWA Manual** - A manual of Water Supply Practices developed and approved by the American Water Works Association (AWWA), headquartered at 6666 West Quincy Avenue, Denver, CO., 80235, (303) 794-7711.
14. **AWWA Standard** - A standard developed and approved by the American Water Works Association (AWWA).
15. **Backflow** - A hydraulic condition in which a relative difference in pressure causes a nonpotable liquid, gas, or other substance to flow into a potable water system.
16. **Base Flood** - A flood which has a one-percent chance of being equaled or exceeded in any given year.
17. **Base Flood Elevation** - The height in relation to mean sea level expected to be reached by the waters of the base flood at pertinent points in the floodplain of riverine areas.
18. **Bedrock** - A massive continuous body of consolidated material connected by strong permanent cohesive forces and having limited filtering and treatment properties.
19. **Best Management Practice** - Alternative structural and nonstructural practices proven effective in erosion control and management of surface runoff.

20. **Best Management Practice Handbook** - The most current edition of the Nevada Division of Environmental Protection manual addressing non-point source water quality practices, for the non-designated area water quality plan.
21. **Bicycle Lane (Bike Lane)** - A portion of a roadway which has been designated by striping, signing and pavement markings for the preferential or exclusive use of bicyclists.
22. **Bicycle Path (Bike Path)** - A bikeway physically separated from motorized vehicular traffic by an open space or barrier and either within the roadway right-of-way or within an independent right-of-way.
23. **Bicycle Route (Bike Route)** - A segment of a system of bikeways designated by the jurisdiction having authority with appropriate directional and informational markers, with or without specific bicycle route number.
24. **Bikeway** - Any road, path or way which in some manner is specifically designated as being open to bicycle travel, regardless of whether such facilities are designated for the exclusive use of bicycles or are to be shared with other transportation modes.
25. **Block** - A tract of land bounded by streets, or by a combination of streets and public parks, cemeteries, railroads, shorelines of waterways, or boundary lines of municipalities.
26. **Board** - The Board Douglas County Commissioners, unless otherwise specified.
27. **Building** - Any structure having a roof supported by columns or walls, not including a travel trailer or Recreational Vehicle.
28. **Capital Improvements Program** - A proposed schedule of all future projects listed in order of construction priority together with cost estimates and the anticipated means of financing each project. All major projects requiring the expenditure of public funds over and above the annual local government's operating expenses, for the purchase, construction, or replacement of the physical assets for the community must be included.
29. **Channel** - A natural or artificial watercourse with definite bed and banks to confine and conduct flowing water.
30. **Collector Sewer** - A sewer line which is in a public right-of-way or easement that has only service laterals tributary to it.
31. **Commercial Unit** - Separately identifiable structure or portion thereof utilized or to be utilized by a person engaged in selling, warehousing or distributing a commodity, or in some business activity, or in a profession or some form of economic or social activity or other utilization not falling under single family dwelling or industrial unit.
32. **Connection Charge** - A charge made by the County or utility provider for providing a service to a customer.
33. **Construction Plans** - The maps or drawings and specifications accompanying a development permit application showing the specific location and design of improvements to be installed of

- constructed in accordance with the requirements of the County or service provider. Construction plans are synonymous with improvement plans.
34. **Consulting Engineer** - Person or persons, firm, partnership, or corporation legally authorized to practice Engineering in the State of Nevada who prepares or submits improvement plans and specifications to Douglas County for approval. Consulting engineer is synonymous with design engineer or engineer.
 35. **Conveyance Ditch** - A channel for the flow of water for irrigation supply or irrigation drainage to or from one or more properties within or beyond the boundaries of a development. Conveyance ditch is inclusive of irrigation, water supply, or drainage ditch.
 36. **County** - Douglas County, unless otherwise specified.
 37. **County Engineer** - The Douglas County Engineer or his/her authorized representatives.
 38. **Critical Drainage Area** - The floodplain area where the existing drainage system is inadequate, or where some other unusual drainage pattern or criteria exists.
 39. **Cross-connection** - An unprotected connection or structural arrangement, whether actual or potential, between a public water system and any other source or system, through which it is possible to introduce into any part of the public water system any used water, industrial fluid, gas, or substance other than the potable water intended to supply the system. The term includes any bypass arrangements, jumper connections, removable sections, swivel or change-over devices, or other temporary or permanent devices through which or because of which backflow can occur.
 40. **Cross Lot Drainage** - A drainage system that conveys site runoff towards the low lot line where it is captured in a drainage channel, pipe, or similar structure and directed across lot lines to an approved point of discharge, or detention or retention structure.
 41. **Cubic Foot** - The volume of water which occupies one cubic foot. One cubic foot is equal to 7.481 gallons.
 42. **Cul-de-sac** - A local street with only one outlet and having an appropriate terminus for the safe and convenient reversal of traffic movement.
 43. **Customer** - The person in whose name service is rendered as evidenced by the signature on the application or contract for that service or, in the absence of a signed instrument, by the receipt and payment of bills regularly issued in his name regardless of the identity of the actual user of the service.
 44. **Department** - The Douglas County Community Development Department, unless otherwise specified.
 45. **Design Average Flow** - The average of the daily volumes to be received for a continuous 12 month period expressed as a volume per unit time. However, the design average flow for facilities having critical seasonal high hydraulic loading periods (e.g. recreational areas, campuses, industrial facilities) shall be based on the daily average flow during the seasonal period.

46. **Design** - Includes the planning and engineering of the following: street alignments, grades and widths; drainage and sanitary facilities and utilities including alignment and grades thereof; water system facilities including alignment, size, valving, and fire hydrant locations; location and size of all required easements and rights-of-way; fire roads and fire breaks; lot size and configuration; traffic access; grading; land to be dedicated for park and recreational purposes; and building and equipment and other such specific physical improvements.
47. **Design Engineer** - See Consulting Engineer.
48. **Design Maximum Day Flow (Sewer)** - The largest volume of flow to be received during a continuous 24 hour period expressed as a volume per unit time.
49. **Design Peak Hourly Flow (Sewer)** - The largest volume of flow to be received during a one hour period expressed as a volume per unit time.
50. **Design Storm** - Shall mean a specified rainfall event with a specified precipitation pattern. The design storm shall be defined by a value for precipitation depth at a point or location.
51. **Detention Basin** - A short-term storage basin which is depleted by flow away from the storage basin or location.
52. **Developer** - The person or persons who have made an application to Douglas County to perform development.
53. **Development** - The placement or erection of any solid material or structure; discharge or disposal of any dredged material or any gaseous liquid, solid or thermal waste; grading, removing, dredging, mining or extraction of any soil or materials; change in the density or intensity of use of land, including, but not limited to, any other division of land, change in the intensity of use of water, or of access thereto; construction, reconstruction, demolition, or alteration of the size of any structure including any facility of any private, public or municipal utility; for the purposes of hillside management, any alteration to vegetation. As used in this development code, "structure" includes but is not limited to any building, road, pipe, flume, conduit, siphon, aqueduct, telephone line, and electrical power transmission and distribution line.
54. **Development Code** - Douglas County Development Code, Title 20, unless otherwise specified.
55. **Development Plans** - See Improvement Plans.
56. **Director** - The Director of Community Development or designee.
57. **Disposal Area** - That portion of the on-site sewage disposal system area which contains the disposal trench(es), the designated repair area for the disposal trench(es), and which provides for the required trench separations and meets the required setbacks.
58. **Disposal Trench** - That terminal portion of an on-site sewage disposal system that receives effluent from the septic tank or distribution system for final treatment, absorption, and disposal.
59. **Discharge Permit** - A National Pollutant Discharge Elimination System (NPDES) permit issued by the State of Nevada Division of Environmental Protection for a sewage facility which generates more than 5,000 gallons of sewage effluent per day. This permit imposes limits on the

- facility's effluent. Where treatment facilities require a discharge permit, the developer shall pay all the fees and obtain a discharge permit in the name of the County or service provider.
60. **Distribution Main** - All pipes in a water distribution system other than a service line.
 61. **Distribution Storage** - The storage structures connected to a distribution system.
 62. **Distribution System** - All facilities of a public water system used to deliver finished water to service connections from the source of the water or from any related treatment facilities.
 63. **Division** - The splitting of a larger tract of land into smaller lots or parcels by either the subdivision or parcel map process as authorized by NRS 278.330, et. seq., or 278.461, et. seq. Division does not include splitting of land by the division of land process authorized by NRS 278.471, et. seq.
 64. **Drainage Plan** - A plan prepared and sealed by a Nevada Registered Professional Civil Engineer, for the collection, transporting, treatment and discharge of storm water within and from a subdivision/development.
 65. **Drainage Report** - A technical engineering report prepared and sealed by a Nevada Registered Professional Civil Engineer, whose purpose is to identify and define drainage characteristics associated with a proposed development and to define possible problems and conceptual solutions. In its final form, the drainage report shall transform the defined conceptual solutions to a final drainage plan.
 66. **Easement** - A grant of one or more property rights by the property owner for the use by the public, a corporation or another person or entity.
 67. **Emergency Reserve** - Finished water that is held in storage and reserved for use in an emergency, including a break in a supply line or a failure of a pumping station.
 68. **Engineer** - Person who is retained as a consultant by the owner/developer and is legally authorized to practice engineering in the State of Nevada in accordance with NRS Chapter 625, and includes Project Engineer as used in this title. Engineer is synonymous with consulting engineer or design engineer.
 69. **Engineering Division** - The Douglas County Community Development Engineering Division.
 70. **Engineer of Record** - Person who is retained as a consultant by the owner/developer and is legally authorized to practice engineering in the State of Nevada in accordance with NRS Chapter 625, who is responsible for inspection and testing of development projects in accordance with the requirements of the Douglas County Design Criteria and Improvement Standards.
 71. **Engineered System** - A septic system for the purpose of serving a public or commercial building, where the pumping of sewage or the enhancement or elevation of a soil absorption field is required.
 72. **Engineering Geologist** - Shall mean a geologist experienced and knowledgeable in engineering geology.

73. **Equivalent Dwelling Unit (EDU)** - The estimated quantity of sewage which the sewer system must handle for the specific use compared to the usage of an average detached single family dwelling which has a defined usage of units. Equivalent dwelling unit is synonymous with equivalent residential unit.
74. **Equivalent Residential Unit (ERU)** - That portion of an industrial or commercial development which is equivalent to a detached single residence in terms of wastewater flow. An ERU is assumed to have 25 fixture units, as defined by the Uniform Plumbing Code, and is assumed to generate 250 gallons of sewage per day.
75. **Erosion Control** - Structural or nonstructural techniques applied to a particular site or area to prevent or minimize erosion.
76. **Fault** – A break in the continuity of a rock formation, caused by a shifting or dislodging of the earth’s crust, in which adjacent surfaces are differentially displaced.
- Fault Trace** – a line formed by the intersection of a fault and the earth’s surface, and is the representation of a fault as depicted on a map, including maps of earthquake fault zones.
- Active Fault** - An active fault is a fault which has had displacement or seismic activity during the geologically recent period. In the United States, an active fault is generally defined as a fault which displaced earth materials during the Holocene (Recent) Epoch (during the last 11,000 or so years before present).
- Sufficiently Active Fault** – A fault that displays evidence of Holocene surface displacement along one or more of its segments or branches. Holocene surface displacement may be directly observable or inferred; it need not be present everywhere along a fault to qualify a fault as sufficiently active.
- Well-Defined Fault** – A fault with its trace clearly detectable by a trained geologist as a physical feature at or just below the ground surface. The fault may be identified by direct observation or by indirect methods.
77. **FEMA** - The Federal Emergency Management Agency created in 1978 to provide a single point of accountability for all federal activities related to disaster mitigation and emergency preparedness and response.
78. **Final Map** - A map prepared in accordance with provisions of state statutes and Douglas County Code which is designed to be placed on record in the office of the County Recorder.
79. **Finished Water** - Water that has been treated or otherwise developed in a manner that complies with NAC 445A.450 to 445A.540, inclusive, 445A.656, 445A.657, and 445A.682.
80. **Fire Authority** - The county, city, town, special district, or agency responsible for fire protection in the area of service of a public water system; or the office of the state fire marshal division of the department of motor vehicles and public safety.
81. **Fire Demand** - The total quantity of water required for protection from fire, as determined by the fire authority and expressed in gallons per minute for a specified number of hours.

82. **Fire Flow** - The rate of flow of water, as determined by the fire authority and expressed in gallons per minute, which is required for protection from fire, and can be delivered from a distribution system at a residual pressure of 20 psi at any point in the system.
83. **Flood Insurance Rate Maps (FIRM)** - Official map on which the Federal Emergency Management Agency (FEMA) has delineated both the areas of special flood hazards and the risk premium zones applicable to the community.
84. **Floodplain** - any land area susceptible to being inundated by waters from any source.
85. **Floodway (Regulatory Floodway)** - the channel of a river or other watercourse and the adjacent land area that must be reserved in order to discharge the base flood without cumulatively increasing the water surface elevation more than a designated height.
86. **Fractured Bedrock** - Bedrock possessing fractures, fissures or other similar physical characteristics that pose a threat to groundwater quality by having the capability of transmitting wastewater to groundwater without adequate treatment.
87. **Frontage** - That side of a lot abutting on a street or way and ordinarily regarded as the front of the lot, but is not considered as the ordinary side of a corner lot.
88. **Gallon** - The volume of water which occupies 231 cubic inches.
89. **Geotechnical Engineer** - An engineer experienced and knowledgeable in the practice of soils and geotechnical engineering and legally licensed in the State of Nevada.
90. **Geotechnical Engineering Report** - A report prepared by any person or persons, firm, partnership, or corporation legally licensed to prepare "Geotechnical Engineering Reports" in the State of Nevada. The report may include soils engineering, geologic, and hydrogeologic conditions.
91. **Governing Body** - The Board of County Commissioners of Douglas County.
92. **Grade** - the degree of rise or descent of a sloping surface (see slope).
93. **Ground Water** - Subsurface water in the zone of saturation.
94. **Health Authority** - The officers and agents of the district board of health of the health district in which the area of service of a public water system is located or, if none, the officers and agents of the Health Division.
95. **Health Division** - The Bureau of Health Protection Services of the Nevada State Health Division, an office within the Nevada Department of Human Resources.
96. **Hillside Area** - Any property containing slope areas of 15 percent or greater as designated on the Master Plan slope constraint maps.
97. **House Piping** - All sewer or water piping and fittings installed within the house or building up to and including the last fitting inside or outside the wall.

98. **Impervious Coverage** - Man-made structure, improvement or covering that prevents normal precipitation from directly reaching the surface of the land underlying the structure, improvement or covering. Such structures, improvements and coverings include but are not limited to roofs, decks, surfaces that are paved with asphalt concrete, Portland cement concrete or stone, roads, streets, sidewalks, driveways, parking lots, tennis courts, patios; and land compacted so as to prevent substantial infiltration.
99. **Improvement Plans** - A set of plans depicting the intended improvements for development. The improvement plans shall include all improvements including streets, sidewalks, drainage, curbs and gutters, sewer improvements, water improvements, drainage improvements, and other improvements required by Douglas County. Improvement plans are synonymous with construction plans and development plans.
100. **Improvement Plans of Record (As-Built Plans)** - The plans accepted by the County as the official record drawings of the subdivision or development which are placed on file in the Community Development Department.
101. **Improvements** - Refers to street work, sidewalk, curb, gutter, driveways, wells, water mains, sanitary sewer, storm drainage, drainage basins, public utilities, street lights, traffic signals, landscaping, irrigation systems and fences to be installed by the developer on land to be used for public right of way or within easements. See also public improvements
102. **Individual On-Site Sewage Disposal System** - A on-site sewage collection, treatment and disposal system located on a single parcel serving only a single building.
103. **Infiltration** - Groundwater which enters sewers and building connections through defective joints and cracks in pipes and manholes.
104. **Interceptor Sewer** - A sewer line that receives flow from a number of collector sewers and conducts such sewage to a point for treatment or disposal.
105. **International Building Code** – The latest adopted edition of the code published by the International Code Council, Inc.
106. **International Residential Code** – The latest adopted edition of the code published by the International Code Council, Inc.
107. **Irrigation System** - A permanent, artificial watering system designed to transport and distribute water to plants.
108. **Joint ownership** - Ownership among persons who are construed as the same owner; "constructive ownership" means ownership for the purpose of imposing subdivision regulations.
109. **Lake Tahoe Region** - That portion of the Tahoe Basin in Douglas County, Nevada, as delineated on the official maps of the Tahoe Regional Planning Agency.
110. **Land Use Classifications** - Land use classifications as defined in the Douglas County Development Code.

111. **Lateral** - That portion of a sewage collection system that conducts sewage from the edge of a public right-of-way (i.e. customer's property line) to the collector sewer. Maintenance of the lateral from the building to the main is the responsibility of the property owner (i.e. customer).
112. **Law** - A rule or rules established and enforced by Federal, State, County or Municipal authorities.
113. **Leach Field** - A component of an individual sewage disposal system consisting of an absorption trench that utilizes the soil for disposal and treatment of septic tank effluent.
114. **Lot** - A parcel, tract, or area of land established by plat, subdivision, or as otherwise permitted by law, to be used, developed or built upon and which abuts upon a legal means of access. The classification of lots are as defined in the Douglas County Development Code.
115. **Main** - That portion of a sewage collection system to which collector sewers are tributary.
116. **Main Extension** - The extension or replacement of water and/or sewer distribution mains and necessary facilities beyond existing service facilities in accordance with the provisions of the section applicable to main extensions.
117. **Major Drainage Facility** - A channel, or other drainage structure, that has a drainage basin of 100 acres or greater.
118. **Manhole** - An enclosure which provides access to a sewer.
119. **Master Plan** - The Douglas County Master Plan as adopted by the Douglas County Board of Commissioners, as amended.
120. **Mechanical Stabilization** - The application or use of structural measures such as rock rip-rap, gabions, turfstone or an approved equal, to provide sufficient soil cover to prevent soil movement by action of wind or water. Stabilization may include incorporation of vegetative measures if approved, so that in combination the structural and vegetative measures will provide the same or a better level of protection than structural measures alone would provide.
121. **Median** - A paved or planted area separating a street or highway into two or more lanes of opposite direction of travel.
122. **Metered Service** - Service for which charges are computed on the basis of measured quantities of water.
123. **MGSD Service Area** - The MGSD service area as defined in the Minden-Gardnerville Sanitation District ordinances, as adopted by the Board of Trustees of the Minden Gardnerville Sanitation District.
124. **Minden-Gardnerville Sanitation District (MGSD)** - The organization located at 1790 Highway 395, Minden, Nevada.
125. **Minor Arterial** - A roadway which connects with and augments the principal arterial system and provides trips of moderate length at a somewhat lower level of travel ability than the principal arterials.

126. **NACE International** – The organization formerly know as National Association of Corrosion Engineers headquartered at 1440 South Creek Drive, Houston, Texas 77084-4906.
127. **National Institute of Occupational Safety and Health** - The organization affiliated with the U.S. Department of Health and Human Services, Public Health Service, Center for Disease Control, Cincinnati, Ohio.
128. **Natural Drainage** - Water which flows by gravity in channels by the surface topography of the earth prior to changes made by the efforts of man.
129. **Natural Watercourse** - A natural creek, stream or river.
130. **NRS** - Nevada Revised Statutes.
131. **NSF International** - The organization headquartered at 3475 Plymouth Road, P.O. Box 130140, Ann Arbor Michigan 48113-0140, which provides third party standardization services in public health safety and in systems management, including quality and environmental specialties. The term is synonymous with “NSF” and “National Sanitation Foundation.”
132. **Nonresidential Subdivision** - A subdivision whose intended use is other than residential, such as commercial or industrial.
133. **Off-site** - Premises not located within the area of the property to be subdivided or developed, whether or not in the same ownership of the applicant for development application or permit approval.
134. **On-Site Sewage Disposal System** - A system for sewerage collection, treatment and disposal located on the same parcel as the building being served.
135. **OSHA** - The federal Occupational Safety and Health Administration and the Nevada Industrial Relations Division, Department of Business and Industry.
136. **Over-Appropriation of Ground Water** - The condition of a ground water resource which results when the net cumulative impacts of the uses of the resource produce undesired results, which may include not only the depletion of ground water reserves, but also the intrusion of poor quality water, the contravention of existing water rights, the deterioration of the economic advantages of pumping, excessive depletion of stream flow by induced infiltration, and land subsidence.
137. **Parcel Map** - A map filed pursuant to NRS 278.461 to 278.469 inclusive, and Douglas County Code, which creates 4 or fewer lots, parcels, sites, units, plots or interests.
138. **Parkway** - The area of a public right-of-way that lies between the curb and the adjacent property line or physical boundary definition such as fences or walls, which is used for landscaping or passive recreational purposes.
139. **Peak Hour Demand** - The volume of water which must be supplied by a public water system to meet the demand of its customers for water during the hour that the maximum amount of water is used for a yearly period, as determined by historical data.

140. **Peaking Factor** - A numerical factor by which average flows are multiplied to obtain peak flows. Peaking factors will vary with tributary area and time frame.
141. **Pedestrian Walkway** - A pedestrian walkway constructed on a public easement or dedicated right-of-way.
142. **Percolation Rate** - The time expressed in minutes for clear water to drop one inch in a percolation test hole.
143. **Percolation Test** - The procedure for testing soil and rock to derive the representative percolation rate for the proposed sidewall absorption area.
144. **Permanent Service** - Service which, in the opinion of the County is of a permanent and established character. The permanent use of water and/or sewer services may be continuous, intermittent or seasonal in nature.
145. **Person** - Individual; partnership, corporation, governmental agency or other organization operating as a single business entity.
146. **Pitless Adapter** - A commercially manufactured device designed for below-grade attachment to openings through the casing of a water well that permits water service pipes to pass through the wall or an extension of the casing and prevents the entry of contaminants into the well or supply of water.
147. **Planning Commission** - The Douglas County Planning Commission established in accordance with law.
148. **Point of Discharge** - The location at which the drainage as shown on a development's drainage and irrigation plan intercepts the Carson River, Walker River, Topaz Lake, Lake Tahoe, or one of the following as approved by the County: major watercourse, major slough, or other established drainage channel which may include irrigation ditches that accepted all pre-developed flows.
149. **Point-of-Entry Treatment Device** - A device that treats all water entering a home or other building.
150. **Point-of-Use Treatment Device** - A device which delivers treated water to a particular faucet located inside a home or other building.
151. **Primary Standard** - Has the meaning ascribed to it in NAC 445A.450.
152. **Principal Arterial** - A roadway which serves as a continuous route for corridor movements having trip lengths and travel density characteristics indicative of state-wide or interstate travel.
153. **Probable Maximum Flood** - The greatest flood to be expected assuming complete coincidence of all factors that would produce the heaviest rainfall and maximum runoff. The probable maximum flood shall be derived from the probable maximum precipitation. The probable maximum precipitation is the quantity of precipitation that is close to the physical upper limit for a given duration over a particular basin.

154. **Project** - See “development.”
155. **Public Health Risk** - A condition, device or practice which is conducive to the introduction of waterborne disease organisms, or harmful chemical, physical or radioactive substances into a public water system, and which presents an unreasonable threat to public health as determined by the Health Authority.
156. **Public Improvement** - A drainage ditch, roadway, parkway, sidewalk, pedestrian way, tree, lawn, off-street parking area, lot improvement, sewer, water system, paving, drainage, or other facility for which the local government or service provider may ultimately assume the responsibility for maintenance and operation, or which may affect an improvement for which local government responsibility is established.
157. **Public Right-of-Way** - A strip of land acquired by reservation, dedication, purchase, prescription, or condemnation and intended to be occupied by a road, trail, water line, sanitary sewer and/or other public uses.
158. **Public Water System** - Any system, regardless of ownership, which provides the public with piped water for human consumption, if the system has 15 or more service connections used by residents throughout the year or regularly serves 25 or more persons for 60 or more days a year. A public water system includes:
1. Any facility for the collection, pumping, treatment, storage, or distribution of water which is under the control of the operator of the system and used primarily in connection with the system; and
 2. Any facility for the collections, or pretreatment of water which is not under the control of the operator of the system but used primarily in connection with the system.
159. **Pumping Test** - A test that is conducted to determine aquifer or well characteristics.
160. **Reclaimed Wastewater** - Wastewater that, as a result of wastewater reclamation, is suitable for beneficial use or a controlled use that would not otherwise occur.
161. **Residential Equivalent** - The average daily demand for water that is typical of a private residence served by a single service connection. If the demand for water by non residential users is:
1. Known or estimated by an engineer, one “residential equivalent” shall be deemed to be 700 gallons per day for metered service connections and 1,225 gallons per day for unmetered service connections.
 2. Unknown and not estimated by an engineer, one “residential equivalent” shall be deemed to be:
 - (a) The amount obtained when rates of flow for individual activities are computed and totaled, in accordance with Appendix I of the Uniform Plumbing Code, and the sum is divided by 700 gallons per day for metered service connections or 1,225 gallons per day for unmetered service connections; or
 - (b) An aggregate total of 20 fixture units, as determined pursuant to Appendix A of the Uniform Plumbing Code.

162. **Retention Basin** - A storage basin which provides long-term storage and is depleted by evaporation, or infiltration.
163. **Right-of-Way** - See “public right-of-way.”
164. **Roads Classification** - Classification for the purpose of providing for the development of the streets, highways, roads, and rights-of-way in Douglas County, and for their future improvement, reconstruction, realignment, and necessary widening, including provision for curbs and sidewalks, each existing street, highway, road, and right-of-way, and those located on approved and filed maps, have been designated on the road classification system of Douglas County and classified therein. The classification of each street, highway, road, and right-of-way is based upon its location in the respective zoning districts of the local government and its present and estimated future traffic volume and its relative importance and function as specified in the Master Plan. The required improvements must be measured as set forth for each road classification on the Master Plan, community plan, road classification system.
165. **Rural Major Collector** - A roadway which provides service to a community not on an arterial route. They link communities with larger towns or cities, or with arterial roadways.
166. **Rural/Urban Local Roadway** - A minor traffic carrier within a neighborhood characterized by one or two moving traffic lanes and parking along curbs, with no through traffic moving from one neighborhood to another. The system services primarily direct access to abutting land and access to the collector roadway system. Traffic control may be by use of stop or yield signs. The rural/urban local roadway system is made up of facilities not designated as one of the other roadway systems.
167. **Rural/Urban Minor Collector** - A roadway which collects traffic and distributes traffic between arterial and local streets. There may be two or four moving traffic lanes and parking may be allowed adjacent to curbs. Traffic on collectors has right-of-way over traffic from local adjacent streets.
168. **Sale or Lease** - An immediate or future transfer of ownership, or possessory interest in land, including contract of sale, lease, devise, intestate succession, or transfer, of an interest in a subdivision or part thereof, whether by metes and bounds, deed, contract, plat, map, lease, devise, intestate succession, or other written instrument.
169. **Same Ownership** - Ownership by the same person, corporation, form, entity, partnership, or unincorporated association; or ownership by different corporations, firms, partnerships, entities, or unincorporated associations, in which a stockholder, partner, or associate, or a member of his family owns an interest in each corporation, firm, partnership, entity, or unincorporated association.
170. **Sanitary Sewer** - An underground collection system for the conveyance of used water, or wastewater, from a home or community, the latter which may include industrial and commercial wastes, infiltrating ground water, and possibly inflow of surface water.
171. **Secondary Standard** - The requirement as defined by the Nevada Division of Health, Bureau of Health Protection Services which specifies a maximum level for constituents found in a water system which, if exceeded, may adversely affect the public welfare. These standards apply to

- constituents which adversely affect the taste, odor, appearance and other aesthetic qualities of water.
172. **Septic Tank** - A watertight, covered receptacle designed and constructed to receive the discharge of sewage from a building sewer, separate the solids from the liquid, digest the organic matter, store digested solids through a period of detention, and allow the clarified liquids to discharge for final treatment and disposal.
173. **Service Connection** -
1. The point of connection between a public water system and the water system used by a customer of the public water system, at which the public water system loses its authority and control over the water;
 2. If a meter is installed at a cross connection between a public water system and the water system used by a customer of the public water system, the downstream end of the meter; or
 3. At a park for mobile homes or recreational vehicles, the riser for water service.
174. **Service Line** - The pipe and all appurtenances located between a water main of a distribution system and the place where a customer of a public water system uses water.
175. **Service Provided** - Service provided shall mean those services which the County currently provides to its constituents, including the maintenance of streets, curbs, gutter, storm drainage, sanitary sewer and water improvements and street lighting.
176. **Service Wyes** - The fitting by which a sewer lateral is connected to the sewer collector. Service tees are not acceptable.
177. **Setback** - The distance between a building and the nearest property line.
178. **Sewer** - A pipe or conduit used to convey liquid waste. The term encompasses both sanitary and storm sewers.
179. **Sewer System** - The system of conduits, pumps, tanks and structures used for the purpose of conveying sewage from its sources to the downstream limits of the County's sewer mains.
180. **Side Sewer** - That portion of a sewage collection system service line which conducts sewage from a building to the public right-of-way or customer's property line. Side sewers shall be designed and constructed to County specifications but will not be dedicated to the County.
181. **Sidewalk** - An improved (i.e. Portland cement concrete) public pedestrian walkway located adjacent to or immediately near a street.
182. **Single Family Dwelling** - Single residence, mobile home, apartment, habitation or other structure occupied or to be occupied by a single person or family requiring County service.
183. **Slope** - The degree of deviation of a surface from the horizontal, usually expressed in percent or degrees.
184. **Soils Engineer** - See Geotechnical Engineer.

185. **Spring** - A naturally occurring point of discharge where ground water becomes surface water.
186. **Standard Individual Sewage Disposal System (ISDS)** - A septic system for the sole purpose of serving a single family residence which utilizes traditional septic disposal techniques; specifically: gravity flow, septic tank, and leach lines within a natural soil filter. A conventional septic system is synonymous with a standard individual sewage disposal system.
187. **State Specifications** - The current edition of the “Standard Specifications for Road and Bridge Construction”, State of Nevada, Department of Transportation (NDOT).
188. **Storm Sewer** - An underground collection system for the conveyance of surface drainage and other deposited materials borne by surface waters to a point of surface disposal, such as a drainage canal, natural water course, or containment area.
189. **Street** - Any public or private thoroughfare, which affords a primary means of access to abutting property.
190. **Subdivider** - A person who, having an interest in land, causes it, directly or indirectly, to be divided, or who directly or indirectly, sells, leases, or develops, or offers to sell, lease, or develop, or advertises for sale, lease, or development, interest, lot, parcel site, unit, or plat in a division of land, or who engages directly or through an agent in the business of selling, leasing, developing, or offering for sale, lease, or development a division of land or interest, lot, parcel site, unit, or plat in a division of land, or who is directly or indirectly controlled by, or under direct, or indirect common control with the foregoing.
191. **Subdivision** - Has the meaning ascribed to it in NRS 278.320.
192. **Subdivision Ordinance** - The Douglas County Development Code as adopted by the Douglas County Board of Commissioners.
193. **Surveyor** - A person who is retained by the owner/developer and is currently licensed to practice land surveying in the State of Nevada in accordance with NRS Chapter 625.
194. **Tailwater** - The runoff of irrigation water from the lower end of an irrigated field.
195. **Temporary Improvement** - Improvements built and maintained by a subdivider during construction of the division of land and prior to release of the financial security.
196. **Ten State Standards** - The official standard developed and approved by the Great Lakes Upper Mississippi River Board of State Public Health and Environmental Managers, presented in the current edition of the publication “Recommended Standards for Water Works” or the publication “Recommended Standards for Wastewater Facilities.” These documents are available from Health Education Services, P.O. Box 7126, Albany, NY 12224, (518) 439-7286.
197. **Tentative Map** - Has the meaning ascribed to it in NRS 278.019.
198. **Traffic Engineering Study** - A study prepared to gather facts on traffic or parking conditions. Traffic engineering studies include but are not limited to:
- traffic inventories

- volume studies
 - speed studies
 - travel time and delay studies
 - route studies
 - intersection studies
 - roadway operations studies (density studies, conflict studies)
 - sight distance studies
 - public transit studies
 - parking studies
 - traffic impact studies
199. **Uniform Fire Code** - The latest adopted edition of the standards published by the International Conference of Building Officials and the Western Fire Chiefs Association.
200. **Uniform Plumbing Code** - The latest adopted edition of the code published by the International Association of Plumbing and Mechanical Officials.
201. **University of Southern California, Foundation for Cross Connection Control and Hydraulic Research** - The organization at University of Southern California, KAP-200 University Park MC-2531, Los Angeles, CA 90089-2531, (213) 740-2032.
202. **Urban Runoff** - Waters collected from the impervious surfaces such as streets, parking lots and roofs, associated with development of land at densities greater than one dwelling for every two acres or commercial or industrial development. Urban runoff is discharged to a conveyance ditch or other receiving body of water at a discrete point.
203. **Valve Box** - A metal or concrete box or vault set over a valve stem at ground surface to allow access to the stem so that the valve can be opened and closed. A cover for the box is usually provided at the surface to keep out dirt and debris.
204. **Water Main** -
1. A pipe or conduit within a distribution system which is used to supply or intended for the conveyance of water to more than one service connection; or
 2. A dedicated pipeline for the conveyance of water from its source or a pumping station to a treatment facility, storage structure, or distribution system.
205. **Water or Sewer Utility** - A purveyor of water or sewerage facilities.
206. **Water Rights of Acceptable Character** - Certified water rights; permitted water rights that, if used as proposed, will not result in an over-appropriation of the source; vested water rights or adjudicated water rights; certified, permitted, vested and adjudicated water rights shall:
- Be of sufficient priority to provide a reliable supply of water to the proposed development;
 - Not result in a over-appropriation of the source; and
 - Not be invalid as the result of non-use or for other reasons, including improper form.

207. **Water Rights of Unacceptable Character** - A water right that will result in an over-appropriation of the source; or a water right that is insufficient in quality or quantity or reliability of source; or a water right that cannot be utilized to serve the proposed development in a manner consistent with the needs of the development, including consideration of source water quality and quantity, and timing of availability.
208. **Water Supply Ditch** - A ditch conveying water for domestic or agricultural purposes that is owned and/or controlled by a ditch or utility company. A water supply ditch is synonymous with a conveyance ditch.
209. **Water System** - The system of conduits, pumps, tanks, wells and structures used for the purpose of conveying from its sources, treating and conveying to final points of use, all water services requested of the County and on a schedule approved by the County. Specifically included as integral parts of the system are conduits forming a part of the general network of conduits or connected directly or indirectly to said network; all pumps, treatment facilities, tanks and structures used in connection with the collection, treatment and disposition of water; and all appurtenances to the above, either physically or functionally connected therewith.
210. **Water Well** - an encased excavation made by any drilling method for the development of ground water from its source.
211. **Well Yield** - The maximum volume of water as expressed in gallons per minute or cubic feet per second, that can be pumped from a well on a sustained basis without lowering the level of the water below the intake of the pump.
212. **Zoning Ordinance** - Shall mean the Douglas County Development Code as adopted by the Douglas County Board of Commissioners.



Appendix G Hillside Grading

Appendix G. Hillside Grading

1. Applicability

Grading activities in hillside areas with slopes of 15% or greater and having a minimum vertical rise of at least 30 feet (see Figure G-1) must be conducted in accordance with regulations set forth in this section, and as depicted in Appendix G Hillside Grading Graphics.

2. Exemptions

The standards contained in this section shall not apply to those specific developments or applications involving one or more of the following circumstances. Non-applicability of the standards will not be construed to prevent the county engineer, director, the planning commission or the board, upon proper findings, from imposing conditions which may also be contained within this section on approval of any tentative map, parcel map, special use permit, planned development, design review or special plan made after the date of adoption of these standards or the approval of any re-application:

- a. Any ministerial approval including, but not limited to, building permits and grading permits, additions to existing residences and construction of accessory buildings on any tentatively approved or recorded parcels of record created prior to the adoption of this section;
- b. Any development application proposed within an existing structure which does not involve expansion of the structure or additional grading of the site;
- c. Any parcel involving a sanitary landfill operation, landfill related gas recovery and collection systems and ancillary electrical power generating and transfer station facilities as well as equipment storage, administrative facilities and ancillary improvements related to the landfill;
- d. Fire breaks and fire roads required by governmental agencies;
- e. Public recreation trails for pedestrian, equestrian and mountain biking uses;
- f. Any parcel located in a hillside area having only isolated land forms with slopes of 15 percent or greater which have a horizontal run less than 100 feet and a vertical rise less than 30 feet (see Figure G-2);
- g. The construction of public improvements initiated by a public or quasi-public agency including, but not limited to, drainage channels, retention basins, water tanks and pumping stations, provided that such facilities are sited, landscaped and bermed so as to minimize visual impacts;
- h. Boundary line adjustments;
- i. Divisions of land into large parcels.

3. Required Approvals for Projects.

No tentative subdivision map, tentative parcel map, special use permit, building permit, design review, grading permit, construction permit or other discretionary approval shall be granted for a project unless the person or entity authorized to grant approval affirmatively finds, in addition to the required findings for the underlying discretionary approval, that the project complies with the provisions of this section.

4. Processing Procedures and Submittal Requirements for Projects.

- a. For every non-exempt building or construction permit application which requires a grading permit under the Uniform Building Code as adopted by Douglas County and for every non-exempt tentative subdivision map, tentative parcel map, design review, special use permit or other discretionary approval of a project which proposes to disturb areas as defined in Section 1 Applicability, the applicant must submit the items and information listed in paragraphs b and c of this section to the community development department. This list is not exclusive and additional information or studies may be required for review of the project pursuant to the requirements of the underlying zoning district, process or procedure for review being applied for, and laws pursuant to the Nevada Revised Statutes, the Uniform Building Code as adopted by the County or these standards.
- b. An applicant must submit the following to the community development department unless specifically waived by the director:
 - i) Slope Analysis (see Figure G-3).
 - aa) The slope analysis must specifically identify and calculate the slope percentages for each topographic feature. Horizontal runs used to calculate slopes must be limited to each individual feature.
 - bb) Total land area within each category must be indicated on a table to be provided on the map face.
 - ii) Grading plan.
 - aa) A grading plan, prepared by a Nevada licensed professional engineer, must include the height and width of all manufactured slopes, proposed drainage patterns, methods of storm water detention or retention, and identification of areas to remain in a natural state must be clearly shown. Off-site contours for adjacent, unimproved areas within 100 feet of the project's boundaries must be provided. When adjacent property is improved, pad elevations, access streets, street grades, wall sections, and any approved or existing improvements immediately adjacent to the subject property, must also be shown.
 - bb) One copy of the grading plan showing cut and fill areas, including preliminary building pad locations, driveway location and access points.
 - iii) Cross sections, preliminary cut and fill.
 - aa) No less than two cross sections which completely traverse those portions of the property proposed to be graded at appropriately spaced intervals in locations where topographic variation is the greatest. The exhibits must be prepared by a registered Nevada licensed professional engineer. The cross sections must clearly depict the vertical variation between natural and finished grade.
 - iv) Erosion Control and re-vegetation plan.
 - aa) An erosion control and re-vegetation plans must be submitted and prepared by a Nevada licensed landscape architect, registered forester or licensed civil engineer and must include at least the following:
 - bb) A survey of existing trees, large shrubs and ground covers.
 - cc) A plan of the proposed re-vegetation of the site detailing existing vegetation to be preserved, new vegetation to be planted and any modifications to existing vegetation.
 - dd) A plan for the preservation of existing vegetation during construction activity.

- ee) A maintenance program including initial and continuing maintenance for re-vegetated areas as necessary.
- v) Fire protection report. If a project is located in a high fire hazard area, a fire protection report is to be prepared showing the location of fire lanes, fuel breaks, and proposed clear areas. This report must be approved by the fire district in which the project is located.
- c. For projects located in hillside areas with slopes of 25% or greater that are not exempt, the following technical reports must be prepared in accordance with the design criteria and improvement standards for the county and submitted by a Nevada licensed professional engineer (licensed in the appropriate discipline), and filed with the community development department unless specifically waived by the director:
 - i) Hydrology, drainage and flood report for all sites;
 - ii) Soils engineering report of the proposed sites attesting to the stability of all sites, and the appropriateness of the construction method proposed and appropriate setbacks;
 - iii) Engineering geology report attesting to the stability of the sites and addressing the potential of material either above the site or below the site causing a hazard to the site in question or other properties in the vicinity;
 - iv) Engineering for all roads providing access to the proposed sites.

5. Grading Control.

- a. The department may issue a permit when the plans conform to the provisions of this section. The department must consider the purpose, intent and the criteria established in this section, together with applicable standards and must approve the design if all applicable provisions are met.
- b. The applicant or developer must be responsible for the maintenance of all slope planting and irrigation systems until the properties are occupied or until a homeowner's association accepts the responsibility to maintain the landscaping in common areas, or other maintenance district formation is established. These areas must be maintained in perpetuity by the property owner, homeowners association or maintenance district.
- c. Any person who grades in those areas subject to the provisions of these standards without prior county approval of plans for such work, subject to this section, shall be in violation of these standards. Abatement of the violation may include the property owner undertaking the restoration (under county supervision and monitoring), or that failing, county-contracted restoration of the disrupted area. The property owner may be charged the cost of the restoration together with the direct costs of supervision and monitoring of the restoration. If the property owner fails to reimburse the county the costs incurred, a lien against the property for payment may be instituted and collected.
- d. The provisions of this section are in addition to other county code titles and regulations applicable to grading activities within the county including the Uniform Building Code as adopted by the County.
- e. The department may apply conditions when the proposed development does not comply with applicable standards. Conditions may be attached to the approval of grading plans so as to achieve the following objectives:
 - i) The health and safety of the public;
 - ii) The preservation of stream courses and encouraging re-vegetation with drought-tolerant native species;

- iii) The avoidance of excessive building padding or terracing and cut and fill slopes to reduce the scarring effects of grading (see Figure G-4);
- iv) The use of contour grading techniques to ensure optimum treatment of natural hillside and drainage features and soften the impact of grading on hillsides, including rolled, sloping, or split pads, rounded cut and fill slopes (see Figure G-4);
- v) Erosion prevention during construction and long term avoidance through proposed design and maintenance measures.
- vi) Compliance with the provisions of this section.

The plans and drawings may be disapproved but the county must specify the standards that are not met.

6. Grading Standards.

No development in a hillside area shall be approved unless the development, or the development as modified with conditions, complies with the following standards:

- a. For the construction of utilities, all areas of cut must be restored to natural grade and re-vegetated to conform to the character of the surrounding natural terrain. In order to reduce grading disturbance during utility installation, all utilities must be incorporated in common trenches and access roads, where practical.
- b. Mass grading of hilltops, ridges, and ravines is prohibited.
- c. All manufactured or man-modified slopes must be stabilized, made to conform to the surrounding natural terrain, and must be re-vegetated to conform to the natural character of the surrounding area.
- d. The maximum height for manufactured slopes is 30 feet (see Figure G-5).
- e. Manufactured fill slopes adjacent to primary and secondary arterials must be no steeper than 4:1 within landscaped areas and public right-of-ways and must not exceed ten feet in height unless the slope is lower in elevation than the roadway (see Figure G-6).
- f. Grading on the perimeter of the site must not be designed with perimeter downslopes to property lines unless a homeowners association, slope maintenance district, or similar entity is established for maintenance of the downslopes. Exemptions to this requirement may be made for downslopes to property lines with a ratio of 5:1 or less. For interior slopes between lots, manufactured building pads must be designed with up-slopes to property lines.
- g. Plot plans must indicate a minimum 20 foot setback from the rear dwelling wall to the toe or top of a manufactured slope or retaining wall and a minimum 10-foot setback from the side dwelling wall. The only exception to this standard would be in the case of a terraced rear yard where multiple levels of functional yard space are provided (see Figure G-7).
- h. All manufactured slopes must be rounded at the top and at the toe of slope. The radius of the rounded slope shall be calculated by dividing the overall height of the slope by three ($H/3$) (see Figure G-8).
- i. Manufactured slopes in excess of 200 feet in length and greater than eight feet in height must be designed with horizontal curvature that simulates the horizontal surface variations of natural contours.
- j. Cross lot drainage may be utilized to reduce grading if an overall design and method of maintenance is established to the satisfaction of the director. Terrace drains must be subject to

- maintenance by private homeowners associations or individual property owners (see Figure G-9).
- k. Any continuous manufactured slope within a parcel map, serial parcel map or subdivision with a slope ratio of 3:1 or steeper, a vertical height of 20 feet or greater, and which abuts five or more lots (see Figure G-10), shall require the creation of a property owners association or other maintenance entity with provision for the collection of fees or assessments designated specifically to pay costs associated with the maintenance of these slopes, as well as to create easements or homeowners association lots for maintenance of all slopes falling under this category. The slope maintenance entity, rather than individual property owners, will be responsible for maintenance of the slopes. The tentative parcel or subdivision map must be designed to provide access to the slopes by easements which do not access the slopes through individual lots. No fences shall be permitted between lots within the slope easement areas. Slope easement areas may be included as lot area for purposes of calculating lot size. Permanent structures must not be permitted within common slope easement areas.

7. Hillside Streets

Except as otherwise provided in paragraph f below, streets within any project proposed in a hillside area shall be designed and constructed in accordance with the following standards:

- a. Proposed streets in hillside area must fit the natural contours of the land.
- b. If a location of a road between a valley and a ridge is unavoidable, directional pavements should be split, with the principle of grading being half-cut and half-fill versus all fill (see Figure G-11). Split streets may be provided by the subdivider according to the following schedule:
 - i) For one lane in each direction, the split section width of the pavement shall be 14 feet;
 - ii) For two lanes in each direction, the split section width of pavement shall be 22 feet. The median between split streets shall not exceed the slope of two foot horizontal for each one foot vertical; and the median shall be planted by the subdivider and maintained by the subdivider, general improvement district or property owners association, to the satisfaction of the county engineer. Lots may be located between the split pavement when approved by the county engineer.
 - iii) Grades of collector and minor streets may exceed 12 percent to a maximum of 15 percent for a distance not greater than 300 feet in any 2,000 feet of street length;
 - iv) Site visibility must conform to AASHTO/ITE standards or other acceptable standard.
- c. The following minimum dimensions are to be utilized in the design of hillside streets:
 - i) All streets shall have suitable pavement widths, sidewalks and drainage facilities per the design criteria and improvements standards.
 - ii) The width of the graded section shall extend three feet beyond the curb face or edge of sidewalk on the fill side and two feet on the cut side of the street.
 - iii) Parking lanes, eight feet in width, may be required on at least one side of all public streets except where existing topography renders development adjacent to the street impractical, or where the street serves solely as an access road, or where an adequate number of off-street parking spaces are provided on each lot adjacent to the street. Streets without parking lanes shall be provided with emergency parking stalls adequate to contain at least one vehicle per lot fronting the street.

- iv) The following travel lane widths are required in all hillside areas:
- Local streets: Minor streets must have a minimum travel lane of ten feet;
 - Collector streets: Collector streets must have minimum travel lane of 12 feet.
- d. Split level, one-way streets may be permissible in areas of steep terrain when accepted by the county during project review.
- e. Street lighting must be designed to minimize visual impacts and retain rural character while conforming to acceptable safety standards.
- f. Modifications to these standards may be made by the planning commission and board if it can be found that the modifications further the purpose and intent of these standards by reducing grading and overall visual impacts while retaining acceptable traffic safety and street design characteristics as determined by the county engineer.

Hillside Grading Graphics

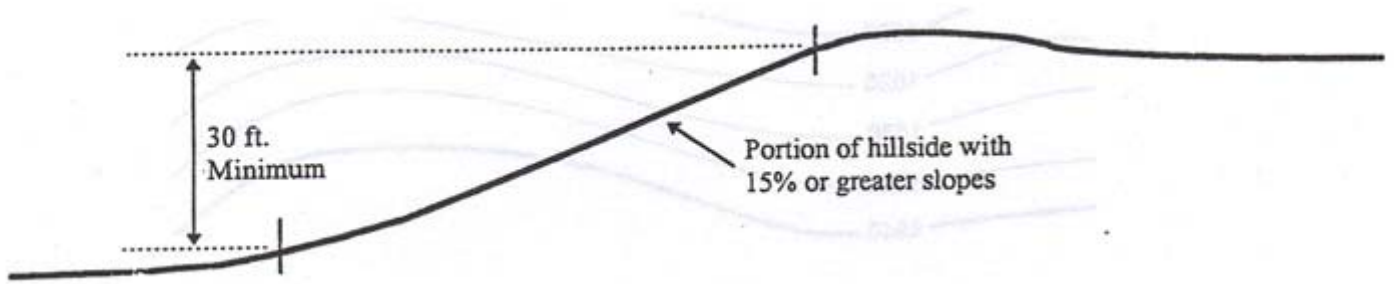

Figure G-1
Applicability

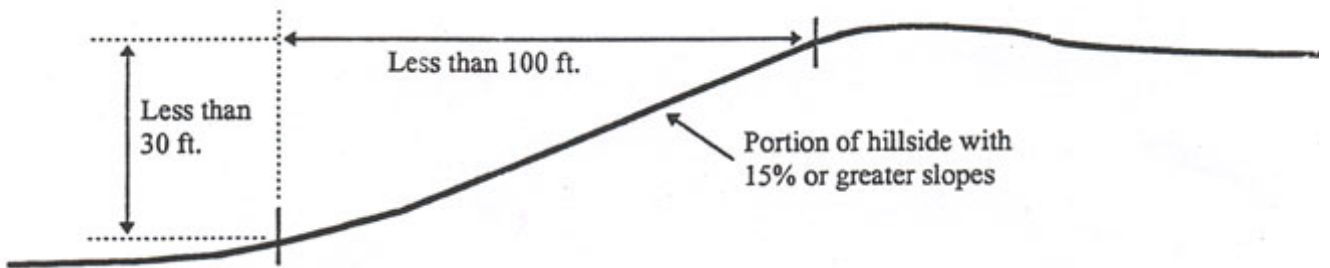

Figure G-2
Exemptions

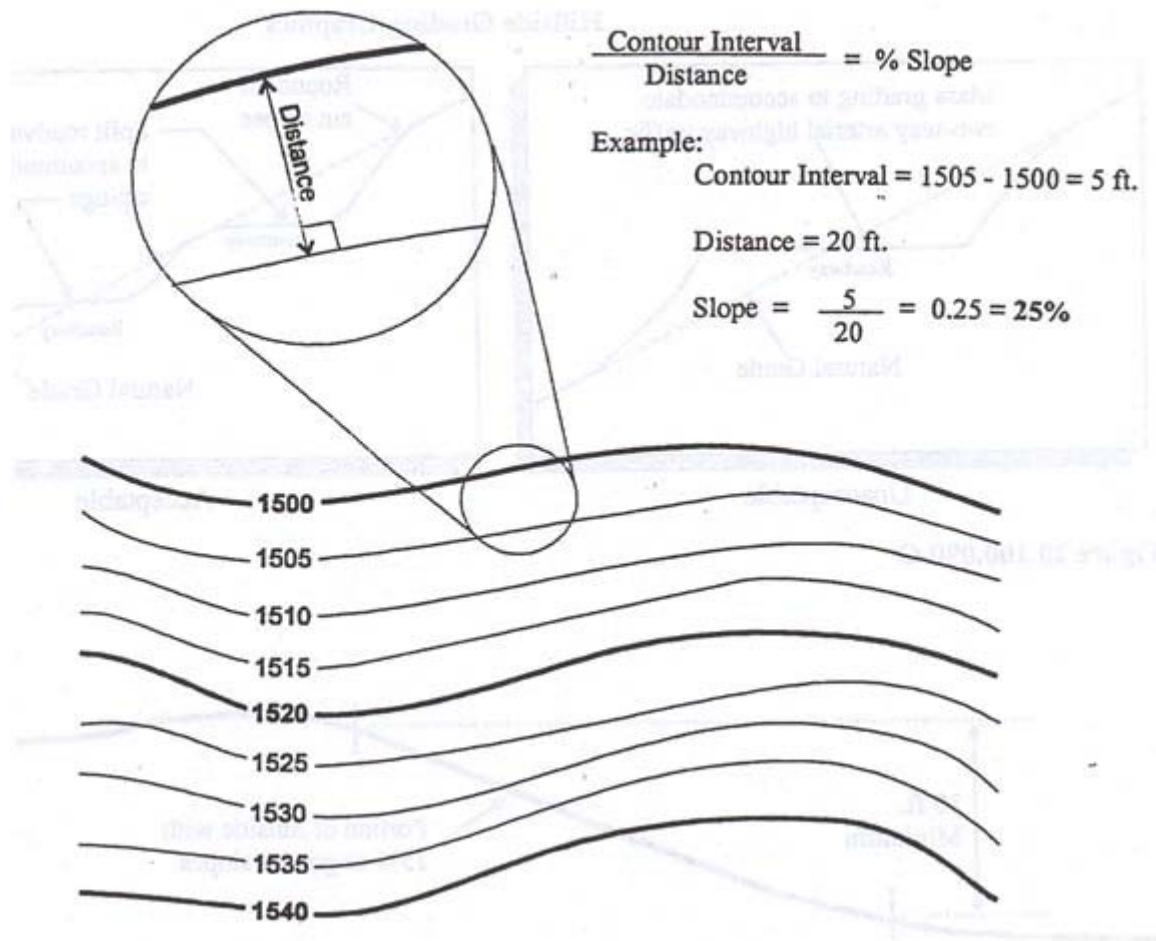
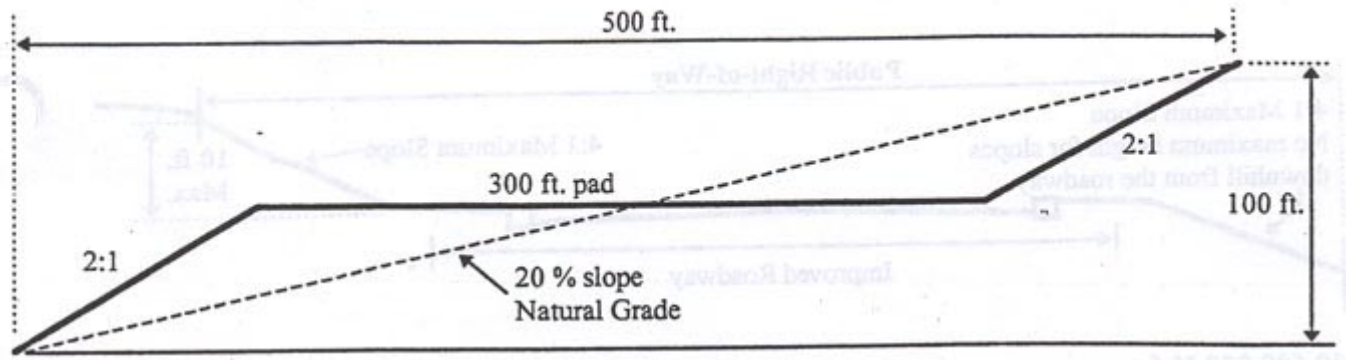
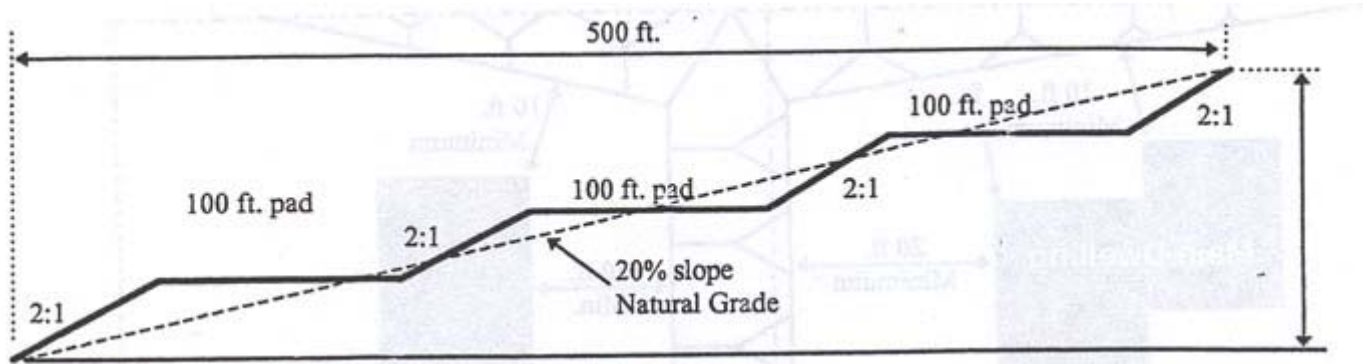

Figure G-3
Slope Analysis (Percentage of slope calculation)



Unacceptable



Acceptable

Figure G-4
Grading Control

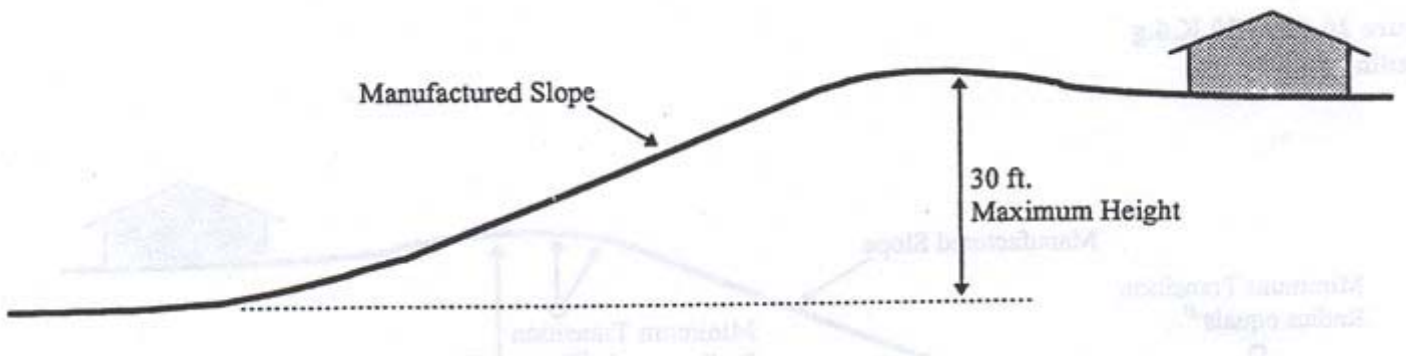

Figure G-5
Manufactured Slopes

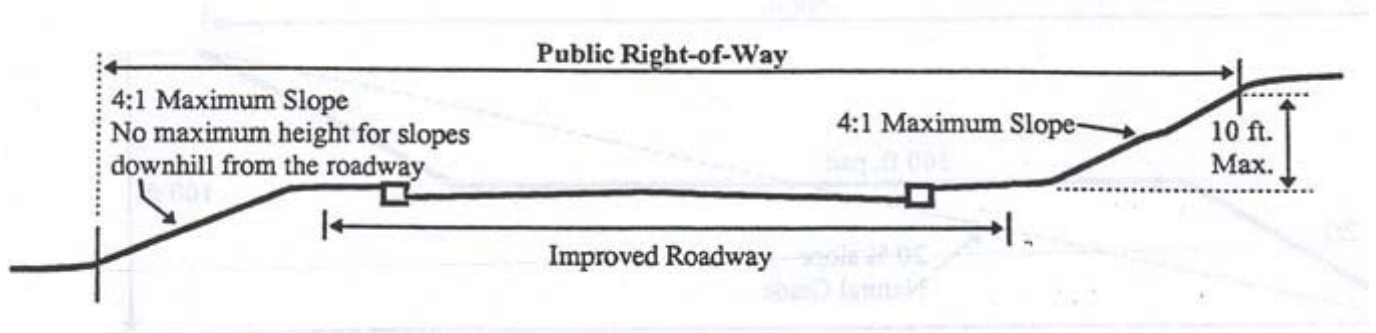

Figure G-6
Manufactured Slopes

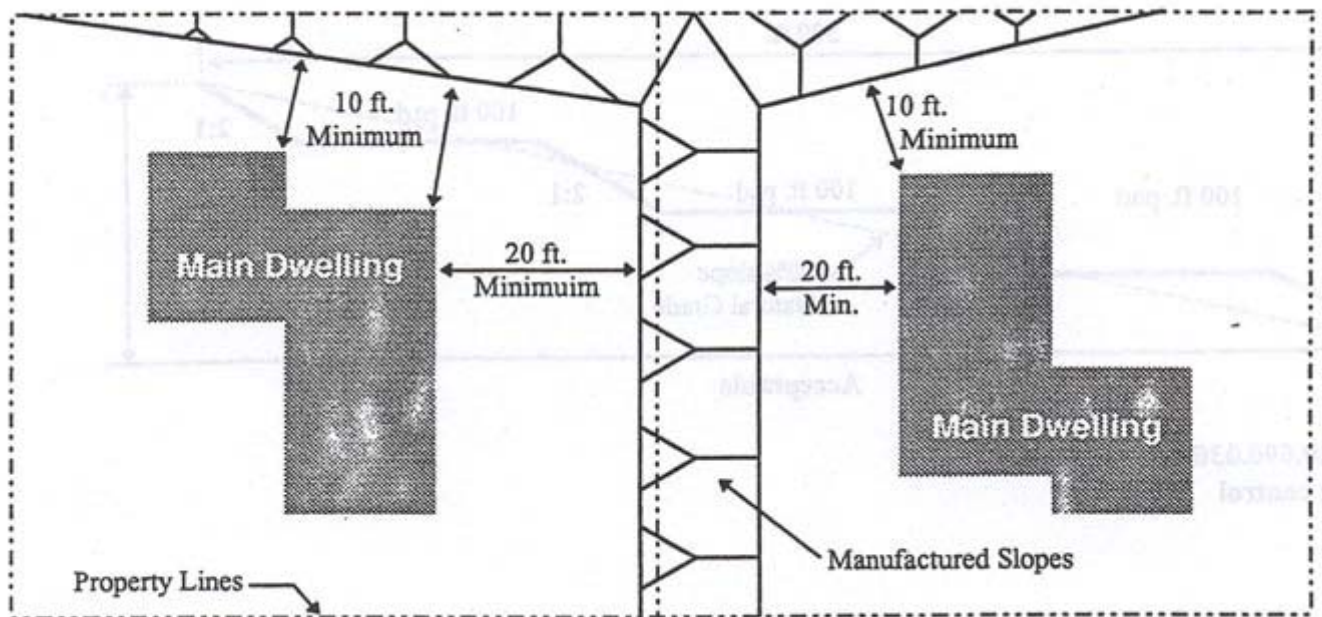
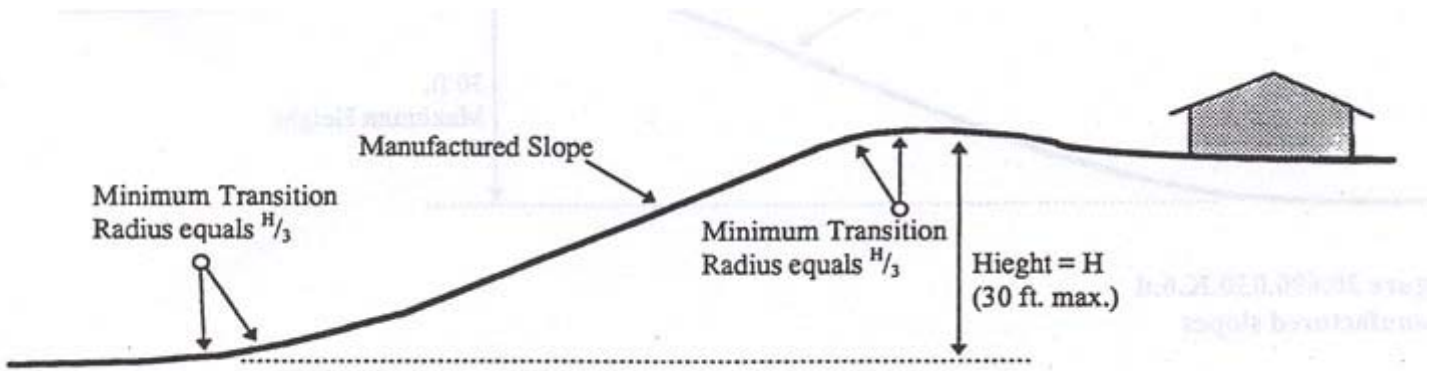

Figure G-7
Grading Standards



FigureG-8
Grading Standards

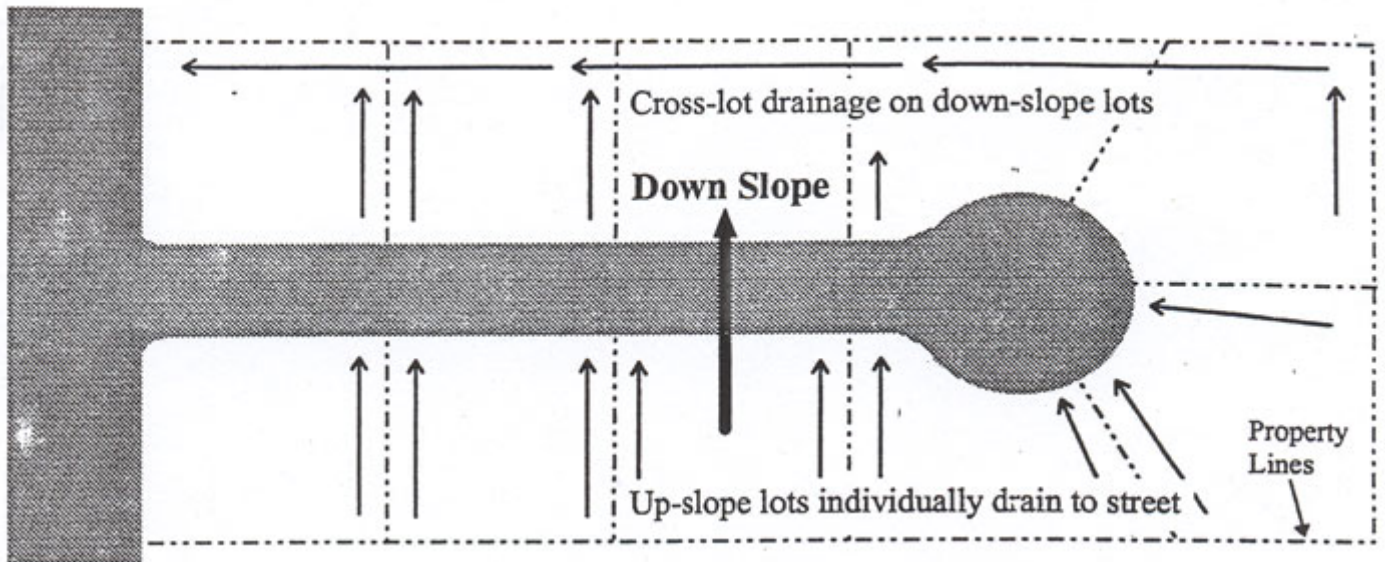

Figure G-9
Grading Standards

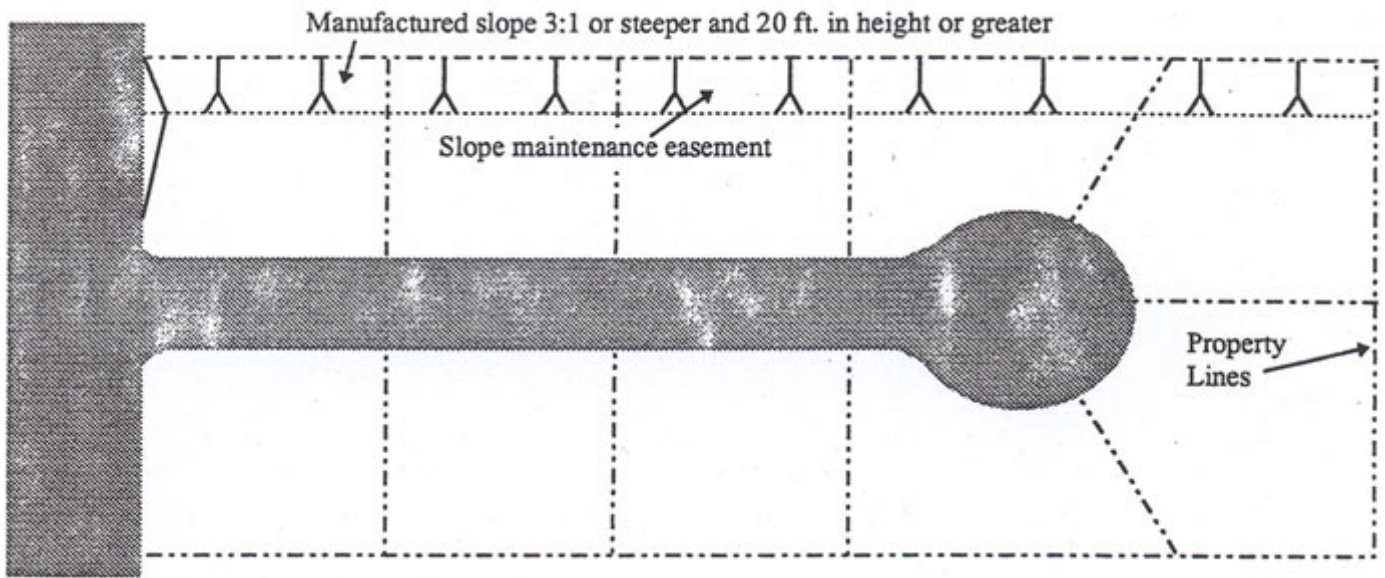
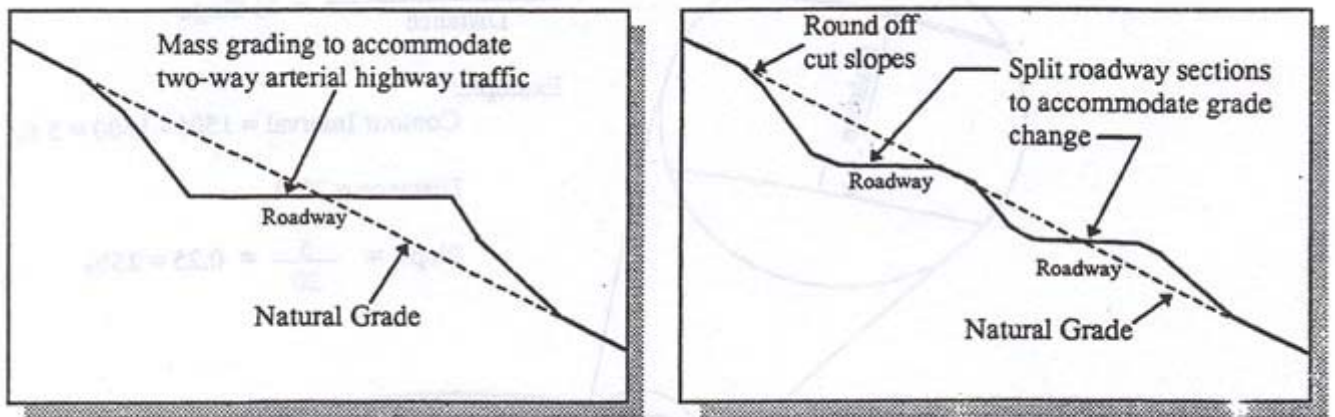

Figure G-10
Grading Standards



Unacceptable

Acceptable

Figure G-11
Hillside Streets